

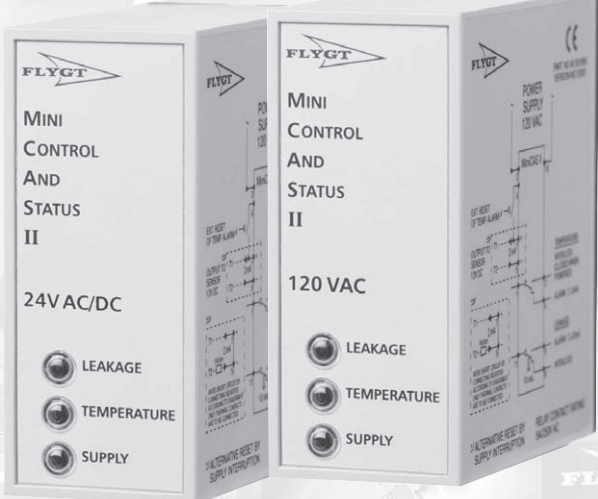

## Technical specification

MiniCAS II, 24 V AC/DC and 120 V AC  
Supervision relay



Flygt



# TECHNICAL DATA

ITT Flygt MiniCAS II is a supervision relay for temperature and leakage sensors. It is designed for the 3000 series pumps up to model 3301 and for the mixer program.

A number of condition monitoring sensors are available for the ITT FLYGT pump range.

- **Thermal switches** for stator overtemperature.
- **CLS** for water in oil detection.
- **FLS** for the detection of liquid in the stator housing.
- **FLS10** for detection of liquid in the inspection chamber in the new midrange pump series, eg 3153, 3171, 3202 and 3301.

The sensors can be used in any desired combination. For "Ex" certified pumps only combinations involving thermal switches, FLS and FLS10 may be used.

On the front, there are three indication lamps, one for supply, one for temperature alarm and one for leakage alarm. For the communication between the pump and the MiniCAS II, only two wires are needed.

The MiniCAS II is designed to be connected to a standard 11-pin socket.

MiniCAS II is interchangeable with the original version of MiniCAS.

Operational principle: Current Sensing  
Approvals: CE, C-UR (covering USA and Canada) and CSA  
Environment: 0–50°C. maximum 90% relative humidity

**Supply voltage 120 V AC:** 120 V AC (50-60 Hz)

Relay contact rating: 250 V AC / 5A

Voltage to sensor: 12 V DC +/-5%

Values of operation: 3 mA < I < 22 mA = OK condition  
I < 3 mA = High Temperature (or interruption)  
I > 22 mA = Leakage (or short circuit), delay 10 sec.

(I = current measured by MiniCAS II)

Power supply required: 5 VA

## OPERATION

Leakage: Changeover contacts 11–8 Normally closed for Interlock  
11–9 Normally open, closes for Alarm

Automatic reset

Red LED for indication – follows the relay

Red indication lamp on: Leakage

Red indication lamp off: No leakage

Temperature: Changeover contacts 1–3 Normally open, closes for Interlock  
1–4 Normally closed for Alarm

Manual reset (see below)

Red Indication lamp on: Overtemperature

Red Indication lamp off: Normal temperature

Reset of temperature alarm:

External reset is possible either by connecting terminals 6 - 7 with an external push button or by interrupting the supply voltage.

Note, in the 24 V version, Reset is also possible between 6-2.

Supply: Yellow indication lamp on: Supply on  
Yellow indication lamp off: Supply off

## DIMENSIONS

Width 33 mm

Height: 79 mm

Depth 75 mm

## PART NOS:

 40 501098 (120 V AC)

# CONNECTIONS

## Leakage alarm will stop the pump

This installation can be used if the leakage alarm shall stop the pump.

It is recommended if the FLS sensor is used. The FLS is detecting liquid in the stator housing, which is critical and requires a quick stop of the pump.

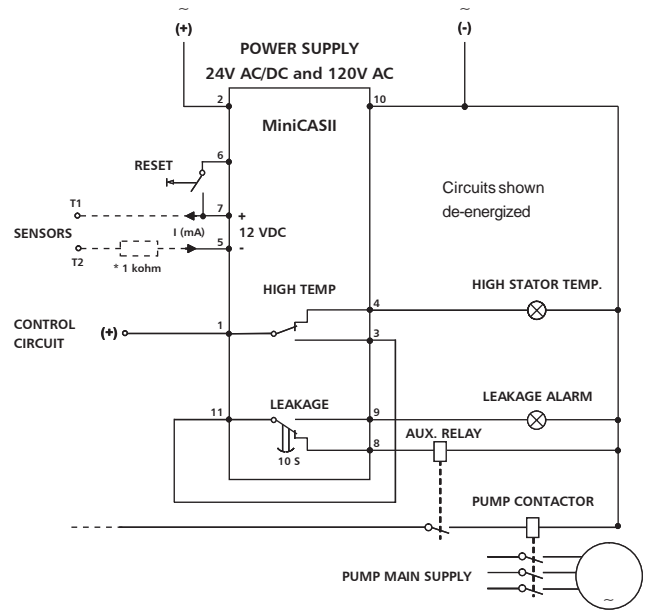

Note, in the 24 V version RESET is also possible between 6-2.

## Leakage alarm will not stop the pump (only warning)

This installation can be used if the leakage alarm shall not stop the pump but give a warning on the Mini-CASII.

It is recommended if FLS10 in inspection chamber or CLS is used. These sensors detect liquid in the inspection chamber (FLS10) and water in the oil (CLS), which is less critical than water in the stator housing.

FLS10 is used in the new midrange pump series, eg 3153, 3171, 3202 and 3301.

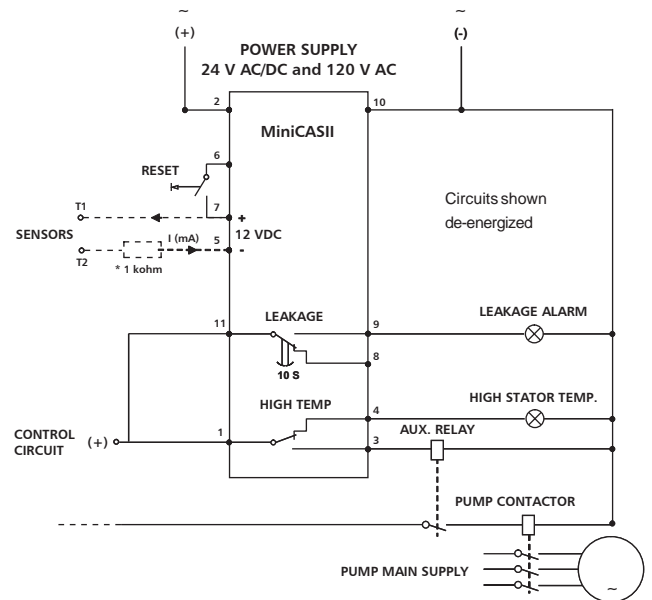

\*) Fit resistor to avoid short circuit if only thermal contacts are to be connected.



[www.flygt.com](http://www.flygt.com)