

# PGR-8800 SERIES (D1000)

Arc-Flash Relay

➔ Cross Reference RA Part Number PN-196562

CE

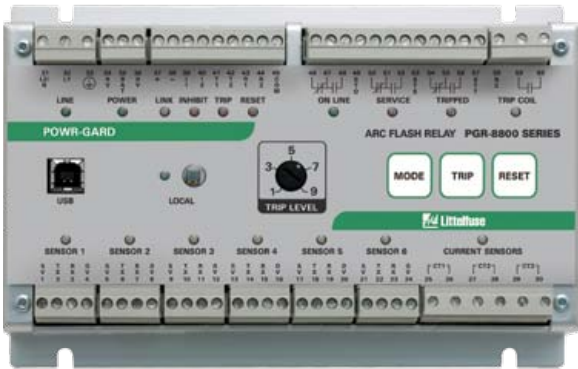

## Description

The PGR-8800 is a microprocessor-based relay that limits arc-fault damage by detecting the light from an arc flash and rapidly tripping. Phase-current-transformer inputs are provided for current-constrained arc-flash protection and, when so equipped, a programmable definite-time overcurrent function can be enabled. An optical sensor on the PGR-8800 and adjustable trip level reduce the chance of nuisance tripping by setting a threshold for ambient light. Sensors, inputs, and connections are monitored to ensure fail-safe operation. A secondary solid-state trip circuit provides a redundant trip path. A USB port is used for configuration and access to event logs and graphs.

## Optical Sensors

The PGR-8800 accepts both PGA-LS10 and PGA-LS20 optical sensors designed to collect light over a wide angle and with high sensitivity. For fast fault location, front-panel and sensor LED's indicate sensor health and which sensor detected an arc fault.

## Sensor Placement

The PGR-8800 Arc-Flash Relay and sensors are easily installed in retrofit projects and new switchgear with little or no re-configuration. Even elaborate systems with multiple power sources take minutes to configure using the relay's built-in USB interface software.

Generally, it is recommended to mount 1 or 2 sensors per cubicle to cover all horizontal and vertical bus bars, breaker compartments, drawers, and anywhere that there is potential for an arc-fault. Threading a fiber-optic sensor through the cabinets and in areas where point-sensor coverage is uncertain results in complete coverage and an added level of redundancy. Even if policy is to only work on de-energized systems, all maintenance areas should be monitored to prevent potential damage and additional cost. At least one sensor should have visibility of an arc fault if a person blocks the other sensor(s).

6

ARC-FLASH PROTECTION



## Simplified Circuit Diagram

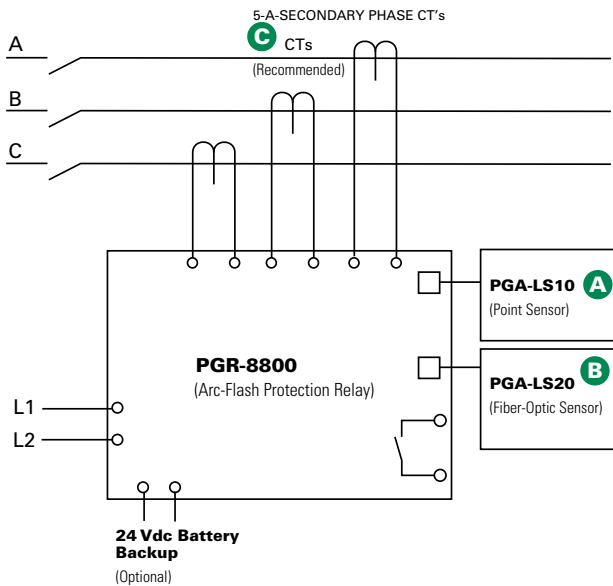

For detailed wiring diagram, see adjacent page and page 155.

## Ordering Information

ORDERING NUMBER	COMMUNICATIONS
PGR-8800-00 (D1000)	Multi-unit linking, USB

ACCESSORIES	REQUIREMENT	PAGE
PGA-LS10 (A1000)	Required*	118
PGA-LS20 (A2000)	Required*	118
Current Transformer	Recommended	114

\*At least one sensor is required. However, the exact number of sensors for proper coverage depends on the application.

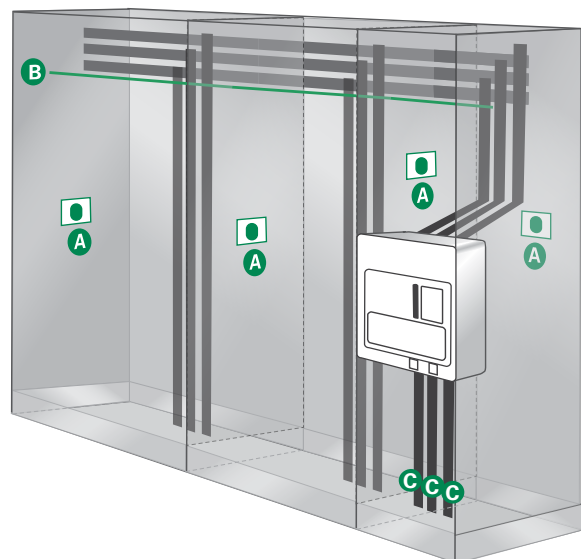

### Features & Benefits

FEATURES	BENEFITS
<b>Arc-Flash trip time &lt;1 ms</b>	Limits arc-flash damage and risk of injury
<b>Multiple sensors (up to 24)</b>	Single module can monitor 6 sensors. Up to 4 PGR-8800 units can be linked into one system
<b>Fail-safe system</b>	Continuous monitoring of optical sensors and inputs ensures protection
<b>Redundant trip circuit</b>	Solid-state backup arc-detection circuit adds a second layer of safety
<b>Adjustable light sensitivity</b>	Allows for operation in bright environments and maximum sensitivity in dark environments
<b>LED indication (on unit and each sensor)</b>	18 LEDs provide at-a-glance status for module and I/O state
<b>Current detection</b>	Phase-CT inputs provide overcurrent protection and prevent nuisance trips
<b>Optical detection</b>	Point and fiber-optic sensors provide wide detection area with sensor health trip indication
<b>Digital inputs (6)</b>	Two each: remote trip, inhibit, and reset inputs
<b>Service mode</b>	Allows for system test without tripping
<b>Trip coil contact</b>	Solid-state 24-600 Vdc/24-440 Vac IGBT
<b>Indication contacts</b>	Form C and status outputs
<b>USB interface</b>	Data logging and configuration software uses a USB interface with no drivers or software installation
<b>Built-in sensor</b>	Can be used in single-sensor systems, as a seventh sensor, and for calibration
<b>Universal power supply/Battery backup</b>	100-230 Vac, 12-60 Vdc, or 100-250 Vdc supply accepted. Ability to charge and run off an external, user-supplied 24 Vdc battery.
<b>Data logging</b>	On-board event recorder helps with system diagnostics

### Wiring Diagram

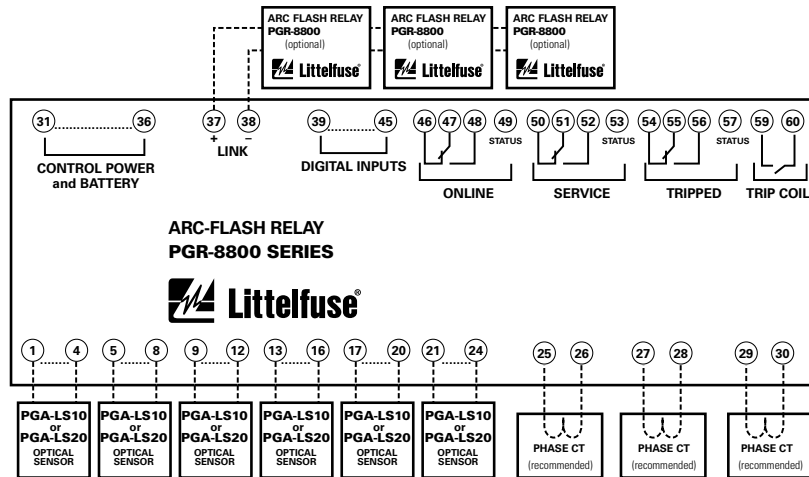

### Accessories

- A**  **PGA-LS10 (A1000) Point Sensor**  
 Line-of-sight light sensor detects an arc as small as 3 kA within a 2-m half-sphere. Sensor health and trip indication.
- B**  **PGA-LS20 (A2000) Fiber-Optic Sensor**  
 360° light sensor for tricky installations with many shadows or to run along bus bars. Sensor health and trip indication.
- C**  **Current Transformers**  
 Eliminate nuisance arc-flash trips and use for overcurrent protection.

### Specifications

<b>IEEE Device Numbers</b>	Overcurrent (50), Arc Flash (AFD)
<b>Input Voltage</b>	100-230 Vac, 12-60 Vdc, and 100-250 Vdc
<b>Dimensions</b>	<b>H</b> 130 mm (5.2"); <b>W</b> 200 mm (7.9"); <b>D</b> 54 mm (2.2")
<b>Optical Trip Settings</b>	10-40 klux, 200 μs-2 s
<b>Current Trip Setting (A)</b>	Programmable
<b>Indication Contact Mode</b>	Fail-safe
<b>Trip Coil Contact Mode</b>	Selectable fail-safe or non-fail-safe
<b>Redundant Trip Circuit</b>	Standard feature
<b>Input Monitoring</b>	Standard feature
<b>USB Interface</b>	Standard feature
<b>Trip, Reset, Service Buttons</b>	Standard feature
<b>Expandable System</b>	Link up to 4 PGR-8800 units
<b>Warranty</b>	5 years
<b>Mounting</b>	DIN (with D0050 adapter clips), Surface

