



Installation Instructions

ControlLogix Data Highway Plus-Remote I/O Communication Interface Module

Catalog Number 1756-DHRIO

Use this document to install the ControlLogix™ Data Highway Plus™-Remote I/O communication interface module.

To	See page
Obtain a User Manual	2
Important User Information	2
Prevent Electrostatic Discharge	6
Identify Module Features	6
Set the Network Type and Node Address Switches	7
Prepare the Chassis for Module Installation	8
Determine Module Slot Location	9
Installing or Removing the Module While Power Is Applied	9
Install the Module	10
Wire the Connectors for the Module Channels	12
Connect the Programming Terminal and DH+ or Remote I/O Network	13
Apply Chassis Power	13
Check Power Supply and Module Status	14
Interpreting the Alphanumeric Display	15
Interpreting the LED Status Indicators	16
Configuring Your 1756-DHRIO Module	17
Hazardous Location information	18
Specifications	19

Obtain a User Manual

This product also has a user manual (pub. no. 1756-UM514). To view it, visit www.ab.com/manuals or www.theautomationbookstore.com. To purchase a manual, you can:

- contact your distributor or Rockwell Automation representative
- visit www.theautomationbookstore.com and place an order
- call 800.963.9548 (USA/Canada) or 001.320.725.1574 (outside USA/Canada)

Change bars are used to indicate information that has changed or been added since the previous version of these instructions.

Important User Information

Because of the variety of uses for the products described in this publication, those responsible for the application and use of these products must satisfy themselves that all necessary steps have been taken to assure that each application and use meets all performance and safety requirements, including any applicable laws, regulations, codes and standards. In no event will Rockwell Automation be responsible or liable for indirect or consequential damage resulting from the use or application of these products.

Any illustrations, charts, sample programs, and layout examples shown in this publication are intended solely for purposes of example. Since there are many variables and requirements associated with any particular installation, Rockwell Automation does not assume responsibility or liability (to include intellectual property liability) for actual use based upon the examples shown in this publication.

Allen-Bradley publication SGI-1.1, *Safety Guidelines for the Application, Installation and Maintenance of Solid-State Control* (available from your local Rockwell Automation office), describes some important differences between solid-state equipment and electromechanical devices that should be taken into consideration when applying products such as those described in this publication.

Reproduction of the contents of this copyrighted publication, in whole or part, without written permission of Rockwell Automation, is prohibited.

Throughout this publication, notes may be used to make you aware of safety considerations. The following annotations and their accompanying statements help you to identify a potential hazard, avoid a potential hazard, and recognize the consequences of a potential hazard:

WARNING



Identifies information about practices or circumstances that can cause an explosion in a hazardous environment, which may lead to personal injury or death, property damage, or economic loss.

ATTENTION



Identifies information about practices or circumstances that can lead to personal injury or death, property damage, or economic loss.

IMPORTANT

Identifies information that is critical for successful application and understanding of the product.

Enclosure and Environmental Requirements

ATTENTION



This equipment is intended for use in a Pollution Degree 2 industrial environment, in overvoltage Category II applications (as defined in IEC publication 60664-1), at altitudes up to 2000 meters without derating.

This equipment is considered Group 1, Class A industrial equipment according to IEC/CISPR Publication 11. Without appropriate precautions, there may be potential difficulties ensuring electromagnetic compatibility in other environments due to conducted as well as radiated disturbance.

This equipment is supplied as "open type" equipment. It must be mounted within an enclosure that is suitably designed for those specific environmental conditions that will be present and appropriately designed to prevent personal injury resulting from accessibility to live parts. The interior of the enclosure must be accessible only by the use of a tool. Subsequent sections of this publication may contain additional information regarding specific enclosure type ratings that are required to comply with certain product safety certifications.

See NEMA Standards publication 250 and IEC publication 60529, as applicable, for explanations of the degrees of protection provided by different types of enclosure. Also, see the appropriate sections in this publication, as well as the Allen-Bradley publication 1770-4.1 ("Industrial Automation Wiring and Grounding Guidelines"), for additional installation requirements pertaining to this equipment.

Zone 2 Certification

IMPORTANT

The following apply to this product's Zone 2 certification:

- This equipment is not resistant to sunlight or other sources of UV radiation.
- The secondary of a current transformer shall not be open-circuited when applied in Class I, Zone 2 environments.
- Equipment of lesser Enclosure Type Rating must be installed in an enclosure providing at least IP54 protection when applied in Class I, Zone 2 environments.
- This equipment shall be used within its specified ratings defined by Allen-Bradley.
- Provision shall be made to prevent the rated voltage from being exceeded by transient disturbances of more than 40% when applied in Class I, Zone 2 environments.
- This equipment is intended for use in potentially explosive atmospheres as defined by European Union Directive 94/9/EC.

The LCIE (Laboratoire Central des Industries Electriques) certifies that this equipment has been found to comply with the Essential Health and Safety Requirements relating to the design and construction of Category 3 equipment intended for use in potentially explosive atmospheres, given in Annex II to this Directive. The examination and test results are recorded in confidential report No. 28 682 010.

Compliance with the Essential Health and Safety Requirements has been assured by compliance with EN 50021 (1999).

Prevent Electrostatic Discharge

ATTENTION



This equipment is sensitive to electrostatic discharge, which can cause internal damage and affect normal operation. Follow these guidelines when you handle this equipment:

- Touch a grounded object to discharge potential static.
- Wear an approved grounding wriststrap.
- Do not touch connectors or pins on component boards.
- Do not touch circuit components inside the equipment.
- If available, use a static-safe workstation.
- When not in use, store the equipment in appropriate static-safe packaging.

Identify Module Features

Refer to the figure below to identify module hardware components.

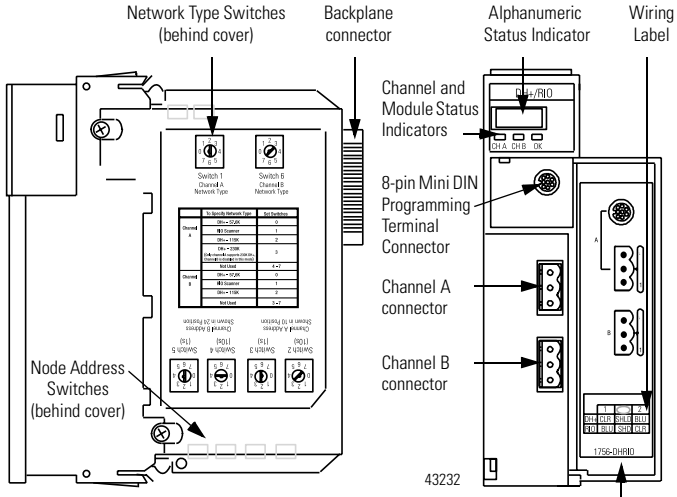

Set the Network Type and Node Address Switches

Before you install the module, you must set the network type switches for each channel. If the network type is Data Highway Plus (DH+), you must also set the node address switches for that channel to a unique address within the range of 00-77.

IMPORTANT

If your module uses the 230k DH+ network (i.e. Channel A switch set to 3), Channel B is disabled.

Also, node address switches do not apply if you are using remote I/O.

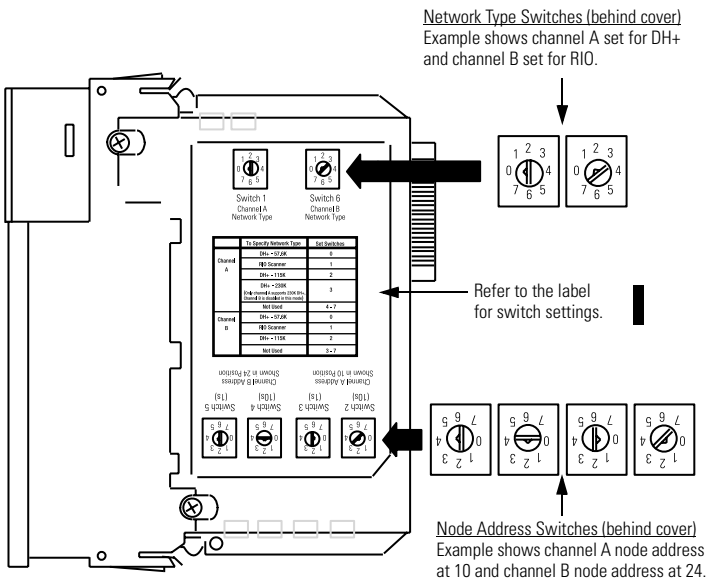

43233

Prepare the Chassis for Module Installation

Before you install the DHRIO module, you must install and connect a ControlLogix chassis and power supply.

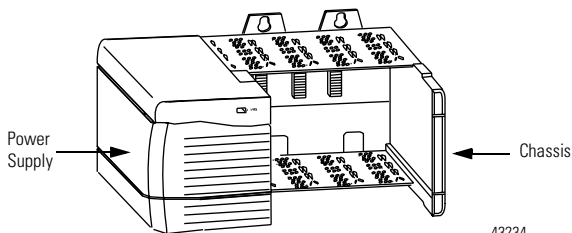

For information on installing these products, refer to the publications listed in the following table.

Chassis Type	Chassis Installation	Power Supply	Power Supply Installation
Series B: 1756-A4, -A7, -A10, -A13, -A17	Pub. No. 1756-IN080	1756-PA72/B	Pub. No. 1756-5.67
		1756-PB72/B	
		1756-PA75/A	Pub. No. 1756-5.78
		1756-PB75/A	

Determine Module Slot Location

The figure below shows chassis slot numbering in a 4-slot chassis. Slot 0 is the first slot and is always the leftmost slot in the rack (the first slot to the right of the power supply). You can use any size ControlLogix chassis and install the module in any slot. You can also install multiple 1756-DHRIO modules in the same chassis. You can install as many modules as your power supply can accommodate (i.e., number for which the power supply is rated).

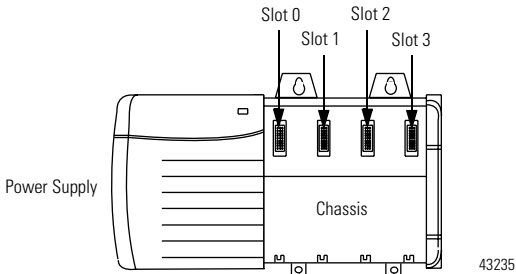

Installing or Removing the Module While Power Is Applied

You can install or remove the module while chassis power is applied if you observe the following precautions.

WARNING



When you insert or remove the module while backplane power is on, an electrical arc can occur. This could cause an explosion in hazardous location installations. Be sure that power is removed or the area is nonhazardous before proceeding.

Repeated electrical arcing causes excessive wear to contacts on both the module and its mating connector. Worn contacts may create electrical resistance that can affect module operation.

Install the Module

ATTENTION



Do not force the module into the backplane connector. If you cannot seat the module with firm pressure, check the alignment. Forcing the module into the chassis can damage the backplane connector or the module.

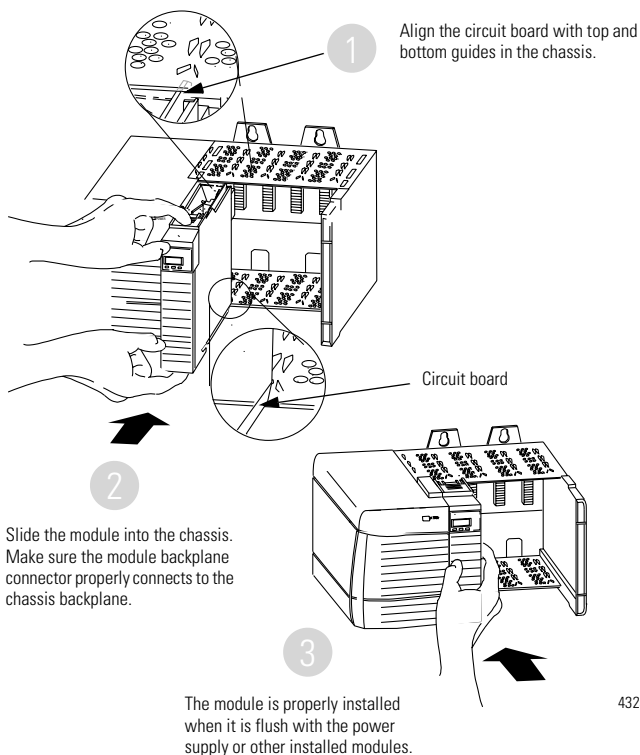

Removing or Replacing the Module (When Applicable)

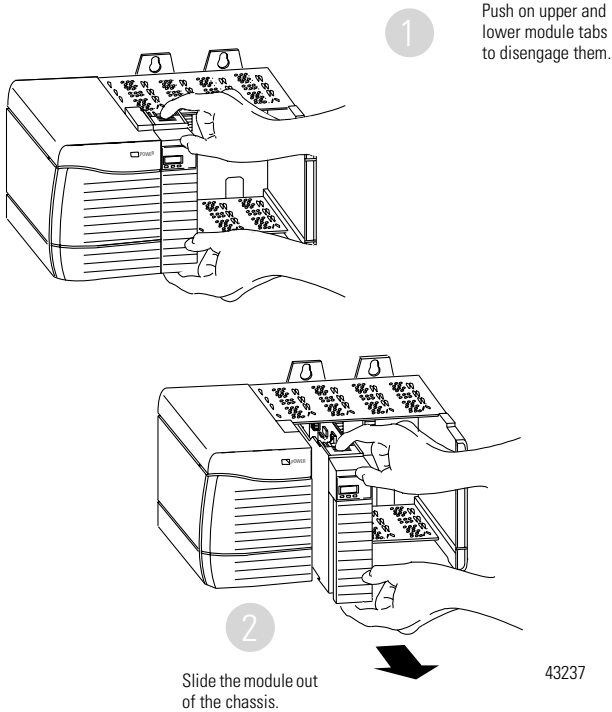

If you are replacing an existing module with an identical one, and you want to resume identical system operation, you must install the new module in the same slot.

Wire the Connectors for the Module Channels

8-pin mini DIN programming terminal connection parallel to channel A when channel A is configured for DH+ communication.

Pin Assignments for Channel A and B Connectors

DH+		Remote I/O	
Pin no:	Desc:	Pin no:	Desc:
1	Clear	1	Blue
	Shield		Shield
2	Blue	2	Clear

43238

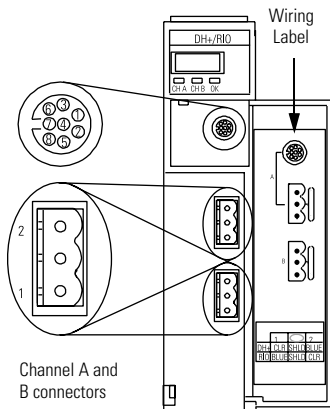

Data Highway +/Remote I/O Communications Connections

WARNING



If you connect or disconnect the DH+ or Remote I/O cable with power applied to this module or any device on the network, an electrical arc can occur. This could cause an explosion in hazardous location installations.

Be sure that power is removed or the area is nonhazardous before proceeding.

Connect the Programming Terminal and DH+ or Remote I/O Network

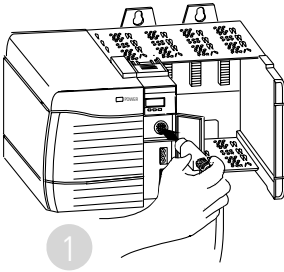

Connect the programming terminal to the 8-pin mini DIN connector.

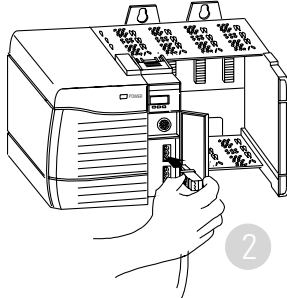

Connect the DH+ or Remote I/O network to the channel A or B connector as appropriate.

43239

WARNING



For hazardous locations, use a 1784-CP13 cable (or equivalent connector) for the programming terminal connection.

Apply Chassis Power

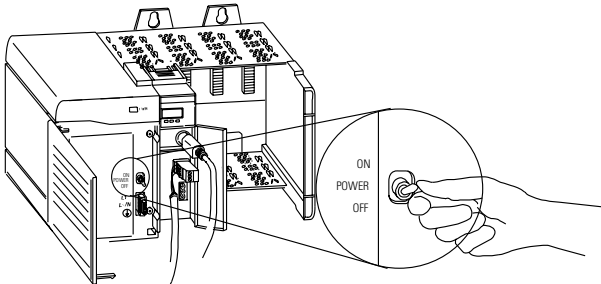

43240

Check Power Supply and Module Status

Alphanumeric status indicator illuminates and cycles through a sequence of messages (described in the table on the following page).

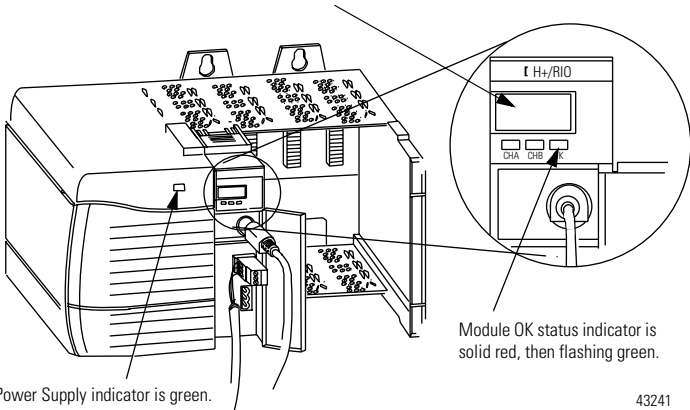

43241

At powerup the module's alphanumeric display begins a cycle through the following sequences.

- Channel A and the network used for channel A - DH+ or RIO
- Channel A node address, if used for DH+
- Channel A status
- Channel B and the network used for channel B - DH+ or RIO
- Channel B node address, if used for DH+
- Channel B status

This sequence runs continuously during normal module operation.

EXAMPLE

For example, if your module uses the following:

- Channel A for DH+ with node address 14
- Channel B for RIO

and the channels are operating properly, you see the following sequence:

- A DH, A#14, A OK, B IO, SCAN, B OK

Troubleshooting the Power Supply

If the alphanumeric indicator on the 1756-DHRIO module does not cycle through these messages on powerup, refer to the following table and to the Troubleshooting section that follows.

If the POWER indicator is:	Power Supply Status is	Recommended Action:
Off	Not operating.	Turn power switch ON. Check power wiring connections. Check fuse.
On	Operating.	None, normal operation.

Interpreting the Alphanumeric Display

Your 1756-DHRIO module displays alphanumeric codes that provide diagnostic information about your module. The alphanumeric display flashes the codes at approximately 1 second intervals. The following table summarizes the codes.

Code	Description	Recommended Action
Data Highway Plus		
OFF LINE	Data Highway Plus link is in STOP state.	Correct the configuration. Refer to the 1756-DHRIO User Manual, publication 1756-UM0514.
DUPL NODE	Data Highway Plus Duplicate node address.	Choose another node address and reset switches.
ONLY NODE	Only node on Data Highway Plus link.	Check the cables.
CNFG FALT	Incorrect DH+ routing table configuration. Incorrect Data Highway object configuration.	Correct the configuration. Refer to the 1756-DHRIO user manual, pub. 1756-UM514 Verify the module is inserted in correct slot.
OK	Normal operation for that channel.	None.
LINK OFF	Channel B is disabled because Channel A is used for 230k DH+ operation.	None

Code	Description	Recommended Action
Remote I/O		
MUTE LINK	No adapters found on remote I/O.	Add an adapter to the remote I/O network.
RACK OVER	Rack overlap on remote I/O.	Reconfigure remote I/O racks.
DUPL SCAN	Duplicate scanner on remote I/O.	Check remote I/O adapter settings.
MAX_DEV_	Maximum devices exceeded on remote I/O.	Remove devices to meet limitations on remote I/O network.
CHAT LINK	Babble detected on remote I/O.	Check remote I/O device and network connections.
OFF_LINE	Not trying to communicate.	None. Normal state if controller is not controlling remote I/O.
OK	Normal operation	None.

Interpreting the LED Status Indicators

The three LED status indicators on the module provide information about your module and the status of each channel. The following tables outline the indicator condition and the corresponding status, and explain what each condition means.

If the Module OK indicator is:	Module Status	Recommended Action
Off	Not operating.	Apply chassis power. Verify module is completely inserted into chassis and backplane.
Green flashing	Operating but not routing messages and no controller transferring I/O.	None, if no messages are actively being routed through the module and no controller transferring I/O. To route messages or transfer I/O, use module default configuration or configure module.
Red, then Off	Performing self-test.	None, normal operation.



If the Module OK indicator is:	Module Status	Recommended Action
Green	Operating and routing messages.	Verify module configuration.
Red	In major fault	Reboot module. If red reoccurs, then replace module.
Red flashing	In major fault or configuration fault.	Check alphanumeric indicator and take action described in alphanumeric display message table on page 15.

If the channel A or B indicator is:	in this channel mode:	then the channel status is:	take this action:
Off	All	Not on line.	Place channel on line.
Green	RIO scanner	Active RIO link. All adapter modules are present and not faulted.	None, normal operation.
	DH+	Operating.	None, normal operation.
Green flashing	RIO scanner	One or more nodes faulted or failed.	Check power at other racks.
	DH+	No other node on the network.	Check cables.
Red	All	Hardware fault.	Reboot module. If red reoccurs, replace module.
Red flashing	RIO scanner	Faulted adapters detected.	Check cables. Check power at other racks.
	DH+	Duplicate node detected.	Check node address.

Configuring Your 1756-DHRIO Module

After installing your 1756-DHRIO module, you must configure it. For more information, refer to the *Data Highway Plus-Remote I/O Communication Interface Module User Manual*, publication 1756-UM514.

Hazardous Location information

<p>The following information applies when operating this equipment in hazardous locations:</p>	<p>Informations sur l'utilisation de cet équipement en environnements dangereux :</p>		
<p>Products marked "CL I, DIV 2, GP A, B, C, D" are suitable for use in Class I Division 2 Groups A, B, C, D, Hazardous Locations and nonhazardous locations only. Each product is supplied with markings on the rating nameplate indicating the hazardous location temperature code. When combining products within a system, the most adverse temperature code (lowest "T" number) may be used to help determine the overall temperature code of the system. Combinations of equipment in your system are subject to investigation by the local Authority Having Jurisdiction at the time of installation.</p>	<p>Les produits marqués "CL I, DIV 2, GP A, B, C, D" ne conviennent qu'à une utilisation en environnements de Classe I Division 2 Groupes A, B, C, D dangereux et non dangereux. Chaque produit est livré avec des marquages sur sa plaque d'identification qui indiquent le code de température pour les environnements dangereux. Lorsque plusieurs produits sont combinés dans un système, le code de température le plus défavorable (code de température le plus faible) peut être utilisé pour déterminer le code de température global du système. Les combinaisons d'équipements dans le système sont sujettes à inspection par les autorités locales qualifiées au moment de l'installation.</p>		
<p style="text-align: center;">WARNING</p> 	<p>EXPLOSION HAZARD</p> <ul style="list-style-type: none"> • Do not disconnect equipment unless power has been removed or the area is known to be nonhazardous. • Do not disconnect connections to this equipment unless power has been removed or the area is known to be nonhazardous. Secure any external connections that mate to this equipment by using screws, sliding latches, threaded connectors, or other means provided with this product. • Substitution of components may impair suitability for Class I, Division 2. • If this product contains batteries, they must only be changed in an area known to be nonhazardous. 	<p style="text-align: center;">AVERTISSEMENT</p> 	<p>RISQUE D'EXPLOSION</p> <ul style="list-style-type: none"> • Couper le courant ou s'assurer que l'environnement est classé non dangereux avant de débrancher l'équipement. • Couper le courant ou s'assurer que l'environnement est classé non dangereux avant de débrancher les connecteurs. Fixer tous les connecteurs externes reliés à cet équipement à l'aide de vis, loquets coulissants, connecteurs filetés ou autres moyens fournis avec ce produit. • La substitution de composants peut rendre cet équipement inadapté à une utilisation en environnement de Classe I, Division 2. • S'assurer que l'environnement est classé non dangereux avant de changer les piles.

Specifications

Module Location	ControlLogix chassis
Maximum Backplane Current Load	850mA @ +5.1V dc and 1.7mA @ 24 V dc from I/O chassis backplane
Power Dissipation	4.5W maximum
Thermal Dissipation	15.4 BTU/hr maximum
Available Baud Rates	57.6Kbaud 115.2Kbaud 230.4Kbaud
Environmental Conditions:	
Operating Temperature	IEC 60068-2-1 (Test Ad, Operating Cold), IEC 60068-2-2 (Test Bd, Operating Dry Heat), IEC 60068-2-14 (Test Nb, Operating Thermal Shock): 0 to 60°C (32 to 140°F)
Storage Temperature	IEC 60068-2-1 (Test Ab, Un-packaged Non-operating Cold), IEC 60068-2-2 (Test Bb, Un-packaged Non-operating Dry Heat), IEC 60068-2-14 (Test Na, Un-packaged Non-operating Thermal Shock): -40 to 85°C (-40 to 185°F)
Relative Humidity	IEC 60068-2-30 (Test Db, Un-packaged Non-operating Damp Heat): 5 to 95% non-condensing
Vibration	IEC 60068-2-6 (Test Fc, Operating): 2g @ 10-500Hz
Shock	IEC 60068-2-27 (Test Ea, Unpackaged Shock): Operating 30g Non-operating 50g
Emissions	CISPR 11: Group 1, Class A
ESD Immunity	IEC 61000-4-2: 6kV contact discharges 8kV air discharges
Radiated RF Immunity	IEC 61000-4-3: 10V/m with 1kHz sine-wave 80%AM from 80MHz to 2000MHz 10V/m with 200Hz 50% Pulse 100%AM at 900Mhz
EFT/B Immunity	IEC 61000-4-4: ±2kV at 5kHz on communications ports

Surge Transient Immunity	IEC 61000-4-5: ±2kV line-earth (CM) on shielded ports
Conducted RF Immunity	IEC 61000-4-6: 3Vrms with 1kHz sine-wave 80%AM from 10kHz to 80MHz 10Vrms with 1kHz sine-wave 80%AM from 150kHz to 80MHz
Enclosure Type Rating	None (open-style)
Screw Terminal Torque	0.5 - 0.6Nm
Conductors: Wire Size Category	Belden 9463 twinaxial 20 AWG (0.519mm ²) 2 ⁽¹⁾
Certifications (when product is marked)	UL CSA UL Listed Industrial Control Equipment CSA Certified Process Control Equipment CSA Certified Process Control Equipment for Class I, Division 2 Group A,B,C,D Hazardous Locations CE ⁽²⁾ European Union 89/336/EEC EMC Directive, compliant with: EN 61000-6-4; Industrial Emissions EN 50082-2; Industrial Immunity EN 61326; Meas./Control/Lab., Industrial Requirements EN 61000-6-2; Industrial Immunity C-Tick ⁽²⁾ Australian Radiocommunications Act, compliant with: AS/NZS 2064; Industrial Emissions EE ⁽²⁾ European Union 94/9/EEC ATEX Directive, compliant with: EN 50021; Potentially Explosive Atmospheres, Protection "n"

⁽¹⁾ Use this conductor category information for planning conductor routing as described in system level installation manual. Also refer to 1770-4.1, *Industrial Automation Wiring and Grounding Guidelines*.

⁽²⁾ See the Product Certification link at www.ab.com for Declarations of Conformity, Certificates, and other certification details.

www.rockwellautomation.com

Corporate Headquarters

Rockwell Automation, 777 East Wisconsin Avenue, Suite 1400, Milwaukee, WI, 53202-5302 USA, Tel: (1) 414.212.5200, Fax: (1) 414.212.5201

Headquarters for Allen-Bradley Products, Rockwell Software Products and Global Manufacturing Solutions

Americas: Rockwell Automation, 1201 South Second Street, Milwaukee, WI 53204-2496 USA, Tel: (1) 414.382.2000, Fax: (1) 414.382.4444

Europe/Middle East/Africa: Rockwell Automation SA/NV, Vorstlaan/Boulevard du Souverain 36, 1170 Brussels, Belgium, Tel: (32) 2 663 0600, Fax: (32) 2 663 0604

Asia Pacific: Rockwell Automation, 27/F Citicorp Centre, 18 Whitfield Road, Causeway Bay, Hong Kong, Tel: (852) 2887 4788, Fax: (852) 2508 1846

Headquarters for Dodge and Reliance Electric Products

Americas: Rockwell Automation, 6040 Ponders Court, Greenville, SC 29615-4617 USA, Tel: (1) 864.297.4800, Fax: (1) 864.281.2433

Europe/Middle East/Africa: Rockwell Automation, Brühlstraße 22, D-74834 Elztal-Dallau, Germany, Tel: (49) 6261 9410, Fax: (49) 6261 17741

Asia Pacific: Rockwell Automation, 55 Newton Road, #11-01/02 Revenue House, Singapore 307387, Tel: (65) 6356-9077, Fax: (65) 6356-9011

Publication 1756-IN003B-EN-P - July 2002

PN 957678-19