

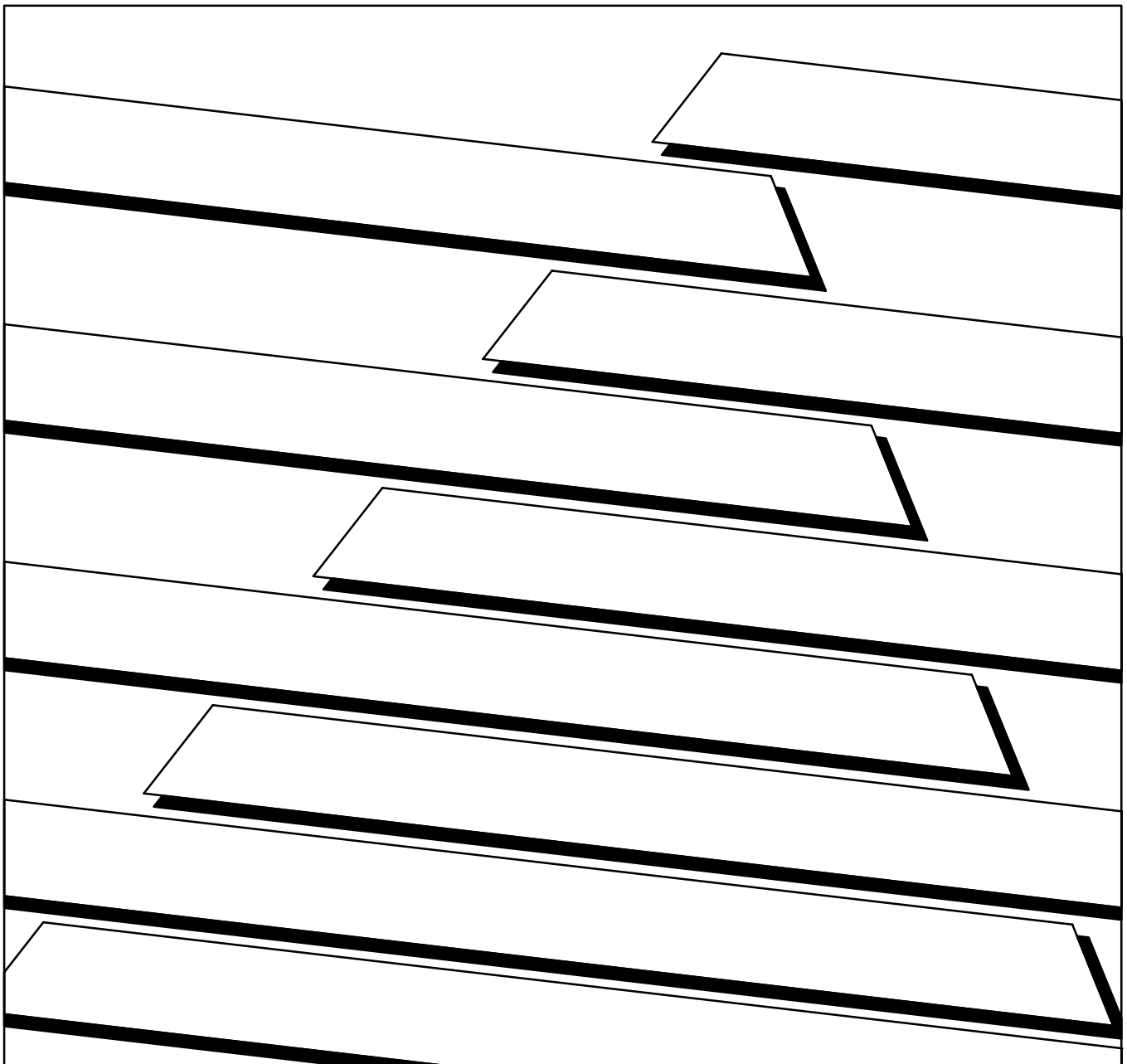

ALLEN-BRADLEY

RTD Input Module Cat. No. 1771-IR Series B

User Manual



Important User Information

Because of the variety of uses for this product and because of the differences between solid state products and electromechanical products, those responsible for applying and using this product must satisfy themselves as to the acceptability of each application and use of this product. For more information, refer to publication SGI-1.1 (Safety Guidelines For The Application, Installation and Maintenance of Solid State Control).

The illustrations, charts, and layout examples shown in this manual are intended solely to illustrate the text of this manual. Because of the many variables and requirements associated with any particular installation, Allen-Bradley Company cannot assume responsibility or liability for actual use based upon the illustrative uses and applications.

No patent liability is assumed by Allen-Bradley Company with respect to use of information, circuits, equipment or software described in this text.

Reproduction of the contents of this manual, in whole or in part, without written permission of the Allen-Bradley Company is prohibited.

Throughout this manual we make notes to alert you to possible injury to people or damage to equipment under specific circumstances.



WARNING: Tells readers where people may be hurt if procedures are not followed properly.



CAUTION: Tells readers where machinery may be damaged or economic loss can occur if procedures are not followed properly.

Warnings and Cautions:

- Identify a possible trouble spot.
- Tell what causes the trouble.
- Give the result of improper action.
- Tell the reader how to avoid trouble.

Important: We recommend you frequently backup your application programs on appropriate storage medium to avoid possible data loss.

Table of Contents

Important User Information	I
Using This Manual	1-1
Purpose of Manual	1-1
Audience	1-1
Vocabulary	1-1
Manual Organization	1-1
Warnings and Cautions	1-2
Related Products	1-2
Product Compatibility	1-2
Related Publications	1-3
Overview of the RTD Input Module	2-1
Chapter Objectives	2-1
Module Description	2-1
Features of the Input Module	2-1
How Analog Modules Communicate with Programmable Controllers	2-2
Accuracy	2-3
Getting Started	2-3
Chapter Summary	2-3
Installing the RTD Input Module	3-1
Chapter Objectives	3-1
Before You Install Your Input Module	3-1
Electrostatic Damage	3-1
Power Requirements	3-2
Module Location in the I/O Chassis	3-2
Module Keying	3-2
Connecting Wiring	3-3
Grounding the Input Module	3-5
Installing the Input Module	3-5
Interpreting the Indicator Lights	3-6
Chapter Summary	3-6
Module Programming	4-1
Chapter Objectives	4-1
Block Transfer Programming	4-1
PLC-2 Program Example	4-2
PLC-3 Program Example	4-4
PLC-5 Program Example	4-6
Module Scan Time	4-7

Chapter Summary	4-7
Module Configuration	5-1
Chapter Objectives	5-1
Configuring Your RTD Module	5-1
Data Format	5-2
RTD Type	5-2
Units of Measure	5-2
Real Time Sampling	5-3
Configuring Block for a Block Transfer Write	5-4
Bit/Word Descriptions	5-5
Default Configuration for the RTD Input Module	5-6
Chapter Summary	5-6
Module Status and Input Data	6-1
Chapter Objectives	6-1
Reading Data from the RTD Module	6-1
Chapter Summary	6-3
Module Calibration	7-1
Chapter Objective	7-1
Tools and Equipment	7-1
Calibrating your Input Module	7-1
About Auto-calibration	7-1
Performing Auto-calibration	7-2
Performing Manual Calibration	7-5
Chapter Summary	7-8
Troubleshooting	8-1
Chapter Objective	8-1
Diagnostics Reported by the Module	8-1
Chapter Summary	8-3
Specifications	A-1
Programming Examples	B-1
Sample Programs for the RTD Input Module	B-1
PLC-2 Family Processors	B-1
PLC-3 Family Processors	B-3
PLC-5 Family Processors	B-4

Data Table Formats	C-1
4-Digit Binary Coded Decimal (BCD)	C-1
Signed-magnitude Binary	C-2
Two's Complement Binary	C-3
Block Transfer (Mini-PLC-2 and PLC-2/20 Processors) ..	D-1
Multiple GET Instructions - Mini-PLC-2 and PLC-2/20 Processors	D-1
Setting the Block Length (Multiple GET Instructions only)	D-4
2 and 4-Wire RTD Sensors	E-1
About 2 and 4-Wire Sensors	E-1
Connecting 4-Wire Sensors	E-2
Differences Between Series A and Series B	
RTD Input Modules	F-1
Major Differences between Series	F-1

Using This Manual

Purpose of Manual

This manual shows you how to use your RTD input module with an Allen–Bradley programmable controller. It helps you install, program, calibrate, and troubleshoot your module.

Audience

You must be able to program and operate an Allen–Bradley programmable controller (PLC) to make efficient use of your input module. In particular, you must know how to program block transfer instructions.

We assume that you know how to do this in this manual. If you do not, refer to the appropriate PLC programming and operations manual before you attempt to program this module.

Vocabulary

In this manual, we refer to:

- The RTD input module as the “input module”
- The Programmable Controller, as the “controller.”

Manual Organization

This manual is divided into eight chapters. The following chart shows each chapter with its corresponding title and a brief overview of the topics covered in that chapter.

Chapter	Title	Topics Covered
2	Overview of the Input Module	Description of the module, including general and hardware features
3	Installing the Input Module	Module power requirements, keying, chassis location Wiring of field wiring arm
4	Module Programming	How to program your programmable controller for these modules Sample programs
5	Module Configuration	Hardware and software configuration Module write block format
6	Module Status and Input Data	Reading data from your module Module read block format
7	Module Calibration	How to calibrate your module
8	Troubleshooting	Diagnostics reported by the module

Chapter	Title	Topics Covered
Appendix A	Specifications	Your module's specifications
Appendix B	Programming Examples	
Appendix C	Data Formats	Information on BCD, signed magnitude (12-bit) binary, and 2's complement binary
Appendix D	Block Transfer with Mini-PLC-2 and Mini-PLC-2/20	How to use GET-GET instructions for block transfer with Mini-PLC-2 and Mini-PLC-2/20 processors
Appendix E	2 and 4-wire RTD Sensors	Shows wiring connections for 2 and 4-wire sensors
Appendix F	Differences Between Series A and B	Identifies major differences between the series A version and the series B version of the RTD module.

Warnings and Cautions

This manual contains warnings and cautions.



WARNING: A warning indicates where you may be injured if you use your equipment improperly.



CAUTION: Cautions indicate where equipment may be damaged from misuse.

You should read and understand cautions and warnings before performing the procedures they precede.

Related Products

You can install your input module in any system that uses Allen-Bradley programmable controllers with block transfer capability and the 1771 I/O structure.

Contact your nearest Allen-Bradley office for more information about your programmable controllers.

Product Compatibility

This input module can be used with any 1771 I/O chassis. Communication between the discrete analog module and the processor is bidirectional. The processor block-transfers output data through the output image table to the module and block-transfers input data from the module through the input image table. The module also requires an area in the data table to store the read block and write block data. I/O image table use is an important factor in module placement and addressing selection. The module's data table use is listed in the following table.

Table 1.A
Compatibility and Use of Data Table

Catalog Number	Use of Data Table				Compatibility			
	Input Image Bits	Output Image Bits	Read Block Words	Write Block Words	Addressing			Chassis Series
					1/2 -slot	1-slot	2-slot	
1771-IR Series B	8	8	8/9	14/15	Yes	Yes	Yes	A and B

A = Compatible with 1771-A1, A2, A4 chassis.
 B = Compatible with 1771-A1B, A2B, A3B, A4B chassis.
 Yes = Compatible without restriction
 No = Restricted to complementary module placement

You can place your input module in any I/O module slot of the I/O chassis. You can put:

- two input modules in the same module group
- an input and an output module in the same module group.

Do not put the module in the same module group as a discrete high density module unless you are using 1 or 1/2 slot addressing. Avoid placing this module close to AC modules or high voltage DC modules.

Related Publications

For a list of publications with information on Allen-Bradley programmable controller products, consult our publication index SD499.

Overview of the RTD Input Module

Chapter Objectives

This chapter gives you information on:

- features of the input module
- how an input module communicates with programmable controllers

Module Description

The RTD input module is an intelligent block transfer module that interfaces analog input signals with any Allen–Bradley programmable controllers that have block transfer capability. Block transfer programming moves input data words from the module’s memory to a designated area in the processor data table in a single scan. It also moves configuration words from the processor data table to module memory.

The input module is a single slot module and requires no external power supply. After scanning the analog inputs, the input data is converted to a specified data type in a digital format to be transferred to the processor’s data table on request. The block transfer mode is disabled until this input scan is complete. Consequently, the minimum interval between block transfer reads (50ms) is the same as the total input update time for each analog input module.

Features of the Input Module

The RTD input module senses up to 6 RTD signals at its inputs and converts them to corresponding temperature or resistance in 4–digit BCD or 16–bit binary format.

Module features include:

- Six resistance temperature detector inputs
- Reports °C, °F, or ohms for 100 ohm platinum or 10 ohm copper sensors
- Reports ohms for other types of sensors
- software configurable
- 0.1 degree/10 milliohm input resolution
- auto–calibration
- open wire detection

The module can be configured for 100 ohm platinum or 10 ohm copper RTDs, or other sensor types such as 120 ohm nickel RTDs. Temperature ranges are available in degrees C or F. Values can also be measured in ohms.

When using 10 ohm copper RTDs, it is necessary to dedicate your module for exclusive use with 10 ohm copper RTDs. You can configure the module to accept signals from any combination of 100 ohm platinum and other types of non–copper RTDs. Both cases are determined by block transfer write (BTW) selection.

How Analog Modules Communicate with Programmable Controllers

The processor transfers data to and from the module using block transfer write (BTW) and block transfer read (BTR) instructions in your ladder diagram program. These instructions let the processor obtain input values and status from the module, and let you establish the module's mode of operation (figure 2.1).

1. The processor transfers your configuration data and calibration values to the module using a block transfer write instruction.
2. External devices generate analog signals that are transmitted to the module.

Figure 2.1
Communication Between Processor and Module

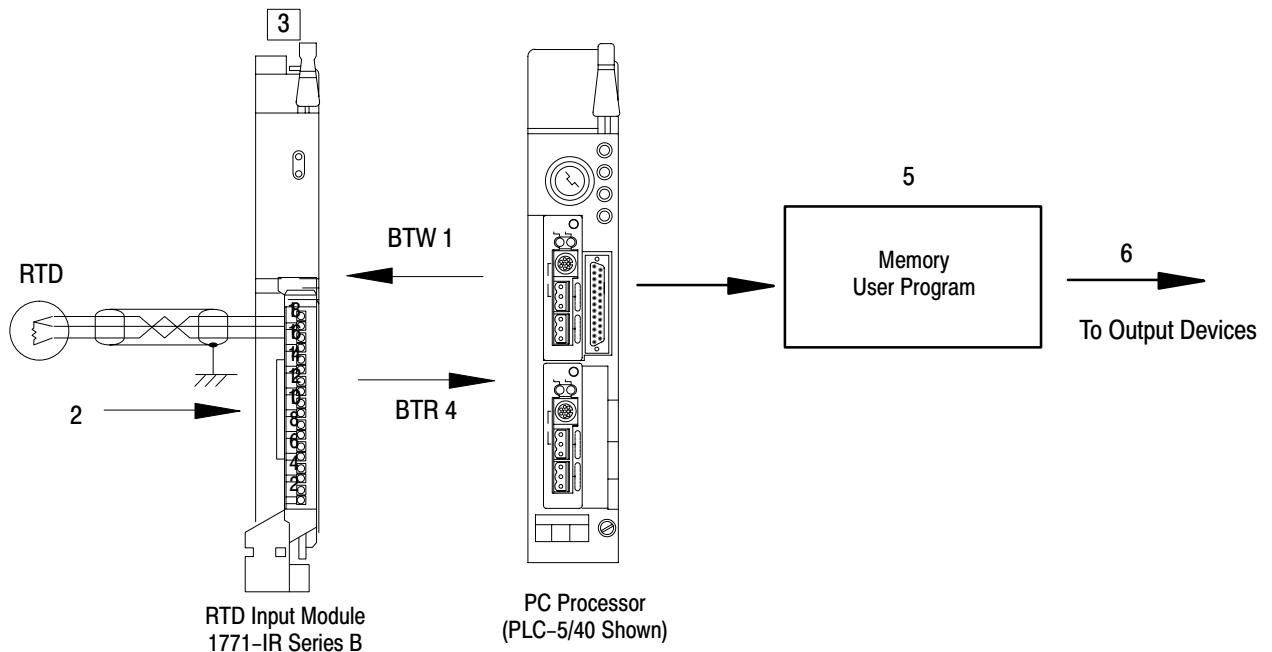

12933-1

3. The module converts analog signals into binary or BCD format, and stores these values until the processor requests their transfer.
4. When instructed by your ladder program, the processor performs a read block transfer of the values and stores them in a data table.
5. The processor and module determine that the transfer was made without error, and that input values are within specified range.
6. Your ladder program can use and/or move the data (if valid) before it is written over by the transfer of new data in a subsequent transfer.

7. Your ladder program should allow write block transfers to the module only when enabled by the operator at power-up.

Accuracy

The accuracy of the input module is described in Appendix A.

Getting Started

Your input module package contains the following items. Please check that each part is included and correct before proceeding.

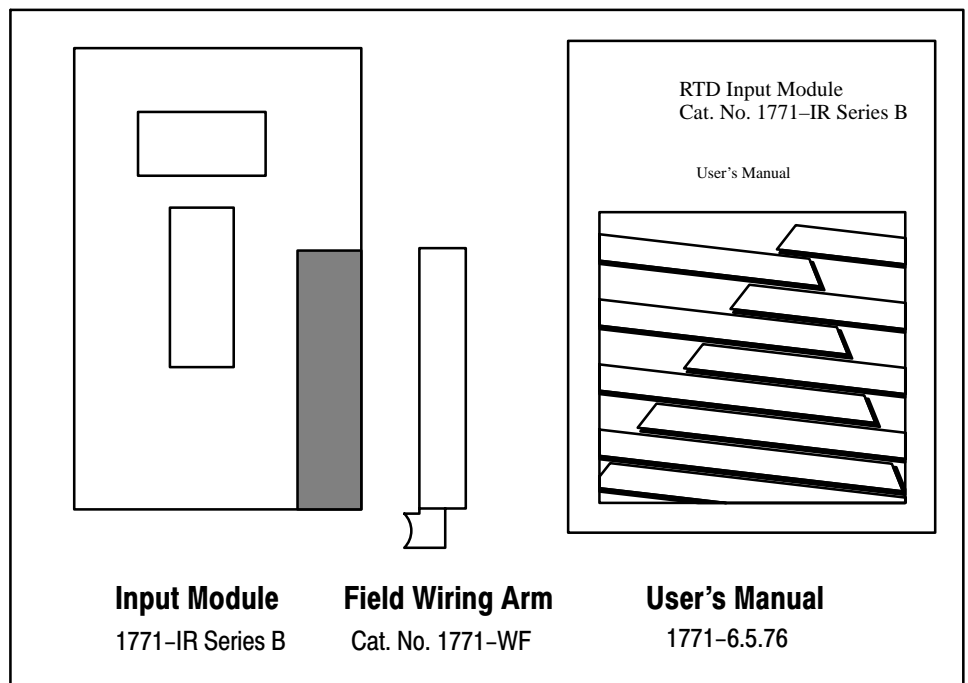

Chapter Summary

In this chapter you read about the functional aspects of the input module and how the module communicates with programmable controllers.

Installing the RTD Input Module

Chapter Objectives

This chapter gives you information on:

- calculating the chassis power requirement
- choosing the module's location in the I/O chassis
- keying a chassis slot for your module
- wiring the input module's field wiring arm
- installing the input module

Before You Install Your Input Module

Before installing your input module in the I/O chassis you must:

Action required:	Refer to:
Calculate the power requirements of all modules in each chassis.	Power Requirements
Determine where to place the module in the I/O chassis.	Module Location in the I/O Chassis
Key the backplane connector in the I/O chassis.	Module Keying
Make connections to the wiring arm.	Connecting Wiring and Grounding

Electrostatic Damage

Electrostatic discharge can damage semiconductor devices inside this module if you touch backplane connector pins. Guard against electrostatic damage by observing the following warning:



CAUTION: Electrostatic discharge can degrade performance or cause permanent damage. Handle the module as stated below.

- Wear an approved wrist strap grounding device when handling the module.
- Touch a grounded object to rid yourself of electrostatic charge before handling the module.
- Handle the module from the front, away from the backplane connector. Do not touch backplane connector pins.
- Keep the module in its static-shield bag when not in use, or during shipment.

Power Requirements

Your module receives its power through the 1771 I/O chassis backplane from the chassis power supply. The maximum drawn by the RTD module from this supply is 850mA (4.2 Watts).

Add the listed value to the requirements of all other modules in the I/O chassis to prevent overloading the chassis backplane and/or backplane power supply.

Module Location in the I/O Chassis

Place your module in any slot of the I/O chassis except for the extreme left slot. This slot is reserved for processors or adapter modules.

Group your modules to minimize adverse affects from radiated electrical noise and heat. We recommend the following.

- Group analog input and low voltage DC modules away from AC modules or high voltage DC modules to minimize electrical noise interference.
- Do not place this module in the same I/O group with a discrete high-density I/O module when using 2-slot addressing. This module uses a byte in both the input and output image tables for block transfer.

After determining the module's location in the I/O chassis, connect the wiring arm to the pivot bar at the module's location.

Module Keying

Use the plastic keying bands, shipped with each I/O chassis, for keying the I/O slot to accept only this type of module.

The input module is slotted in two places on the rear edge of the circuit board. The position of the keying bands on the backplane connector must correspond to these slots to allow insertion of the module. You can key any connector in an I/O chassis to receive this module except for the leftmost connector reserved for adapter or processor modules. Place keying bands between the following numbers labeled on the backplane connector (Figure 3.1):

- Between 10 and 12
- Between 28 and 30

You can change the position of these bands if subsequent system design and rewiring makes insertion of a different type of module necessary. Use needlenose pliers to insert or remove keying bands.

Figure 3.1
Keying Positions for the RTD Input Module

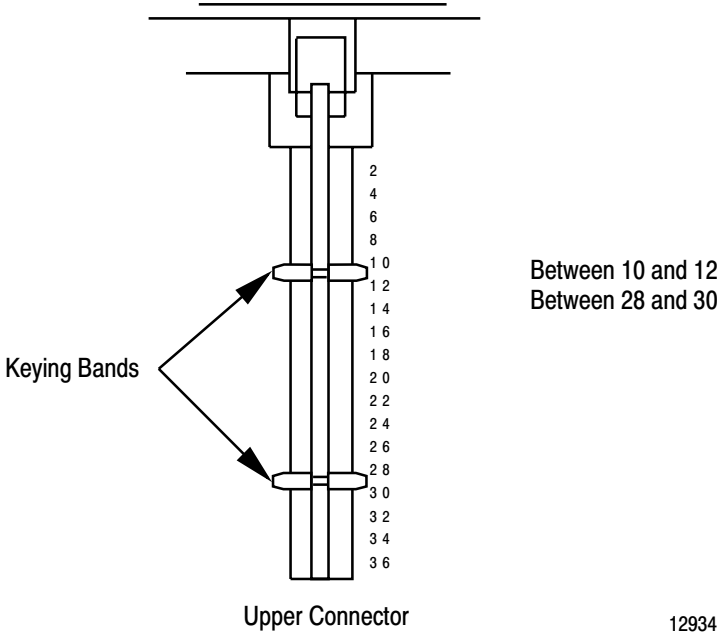

Connecting Wiring

Connect your I/O devices to the field wiring arm shipped with the module (see Figure 3.2). Attach the field wiring arm to the pivot bar at the bottom of the I/O chassis. The field wiring arm pivots upward and connects with the module so you can install or remove the module without disconnecting the wires.

The wiring arms are specific to the input module. The RTD input module uses field wiring arm cat. no. 1771-WF.

Use the inputs in numerical sequence from 1 to 6. Unused inputs that are left open cause the module to report an open input condition. To avoid this, tie all three terminals of the open channel together. Wiring connections are shown in Figure 3.2.

The module requires three-conductor shielded cable for signal transmission from RTD devices. This cable consists of three insulated conductors, covered along their entire length by a foil shield and encased in plastic. The shield reduces the effect of induced noise at any point along the cable. In order to do this, the shield must cover the enclosed wires as completely as possible.

Figure 3.2
Connection Diagram for RTDs

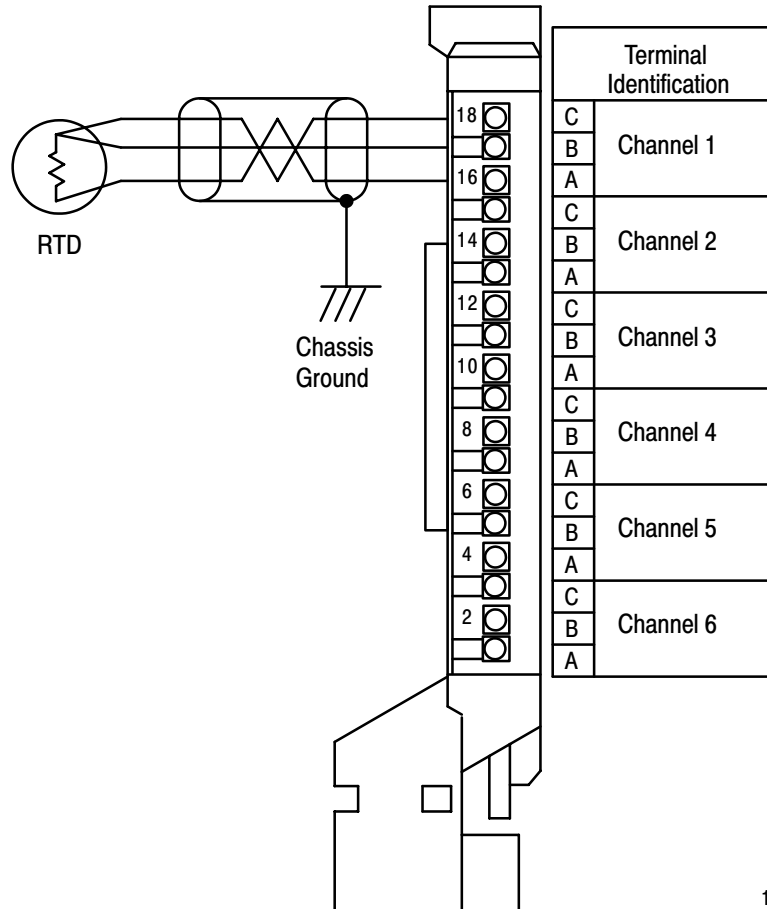

12935

Most importantly, you must ground the shield at the chassis end only. We recommend connecting each input cable's shield to a properly grounded common bus.

Refer to Appendix E for 2-wire and 4-wire RTD connections.

Cable impedance — Since the operating principle of the RTD module is based on the measurement of resistance, you must take special care in selecting your input cables. Select a cable that has a consistent impedance throughout its entire length. We recommend Belden 9533 or equivalent. As cable length is directly related to overall cable impedance, keep input cables as short as possible by locating your I/O chassis as near the RTD sensors as I/O module considerations permit. Keep the cable free of kinks and nicks to the shielding material.

Maximum cable length is limited by an overall cable impedance of 10 ohms on a single wire. This recommendation is based on considerations of signal degradation due to resistance mismatch between the three conductors within the cable.

Grounding the Input Module

When using shielded cable, ground the foil shield and drain wire only at one end of the cable. We recommend that you wrap the foil shield and drain wire together and connect them to a chassis mounting bolt (Figure 3.3). At the opposite end of the cable, tape exposed shield and drain wire with electrical tape to insulate it from electrical contact.

Figure 3.3
Cable Grounding

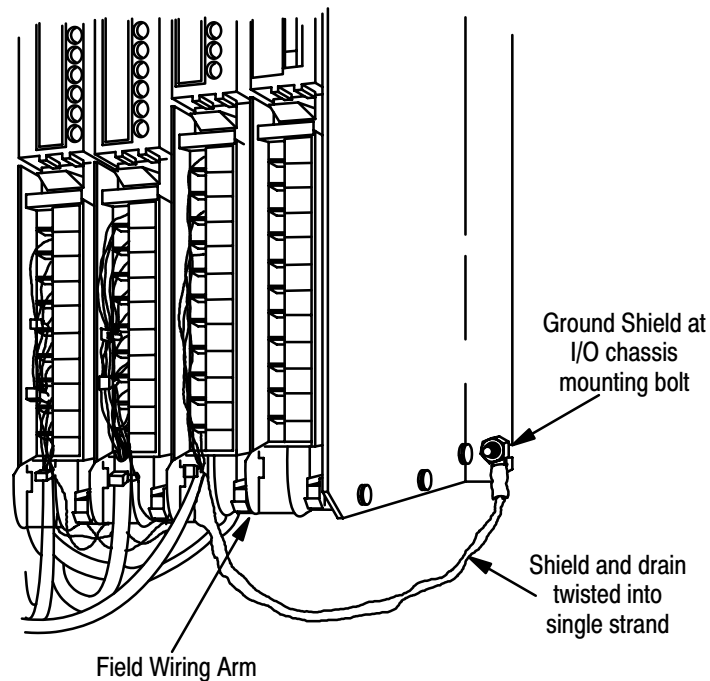

17798

Refer to Wiring and Grounding Guidelines, publication 1770-4.1 for additional information.

Installing the Input Module

When installing your module in an I/O chassis:

1. First, turn off power to the I/O chassis:



WARNING: Remove power from the 1771 I/O chassis backplane and wiring arm before removing or installing an I/O module.

Failure to remove power from the backplane could cause injury or equipment damage due to possible unexpected operation.

Failure to remove power from the backplane or wiring arm could cause module damage, degradation of performance, or injury.

2. Place the module in the plastic tracks on the top and bottom of the slot that guides the module into position.
3. Do not force the module into its backplane connector. Apply firm even pressure on the module to seat it properly.
4. Snap the chassis latch over the top of the module to secure it.
5. Connect the wiring arm to the module.

Interpreting the Indicator Lights

The front panel of the input module contains a green RUN and a red FLT (fault) indicator (Figure 3.4). At power-up, the green and red indicators are on. An initial module self-check occurs. If there is no fault, the red indicator turns off. The green indicator will blink until the processor completes a successful write block transfer to the module. If a fault is found initially or occurs later, the red FLT indicator lights. Possible module fault causes and corrective action are discussed in Chapter 8, Troubleshooting.

Figure 3.4
Diagnostic Indicators

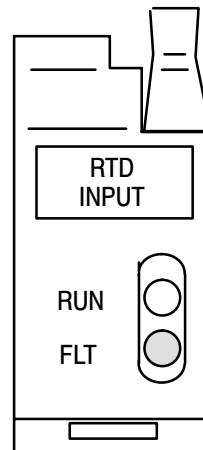

Chapter Summary

In this chapter you learned how to install your input module in an existing programmable controller system and how to wire to the field wiring arm.

Module Programming

Chapter Objectives

In this chapter, we describe

- Block Transfer programming
- Sample programs in the PLC–2, PLC–3 and PLC–5 processors
- Module scan time issues

Block Transfer Programming

Your module communicates with the processor through bidirectional block transfers. This is the sequential operation of both read and write block transfer instructions.

The block transfer write (BTW) instruction is initiated when the analog module is first powered up, and subsequently only when the programmer wants to write a new configuration to the module. At all other times the module is basically in a repetitive block transfer read (BTR) mode.

The following example programs accomplish this handshaking routine. These are minimum programs; all rungs and conditioning must be included in your application program. You can disable BTRs, or add interlocks to prevent writes if desired. Do not eliminate any storage bits or interlocks included in the sample programs. If interlocks are removed, the program may not work properly.

Your analog input module will work with a default configuration of all zeroes entered in the configuration block. See the configuration default section to understand what this configuration looks like. Also, refer to Appendix B for example configuration blocks and instruction addresses to get started.

Your program should monitor status bits (such as overrange, underrange) and block transfer read (BTR) activity.

The following example programs illustrate the minimum programming required for communication to take place.

PLC-2 Program Example

Note that PLC-2 processors that do not have the block transfer instruction must use the GET-GET block transfer format which is outlined in Appendix D.

Figure 4.1
PLC-2 Family Sample Program Structure

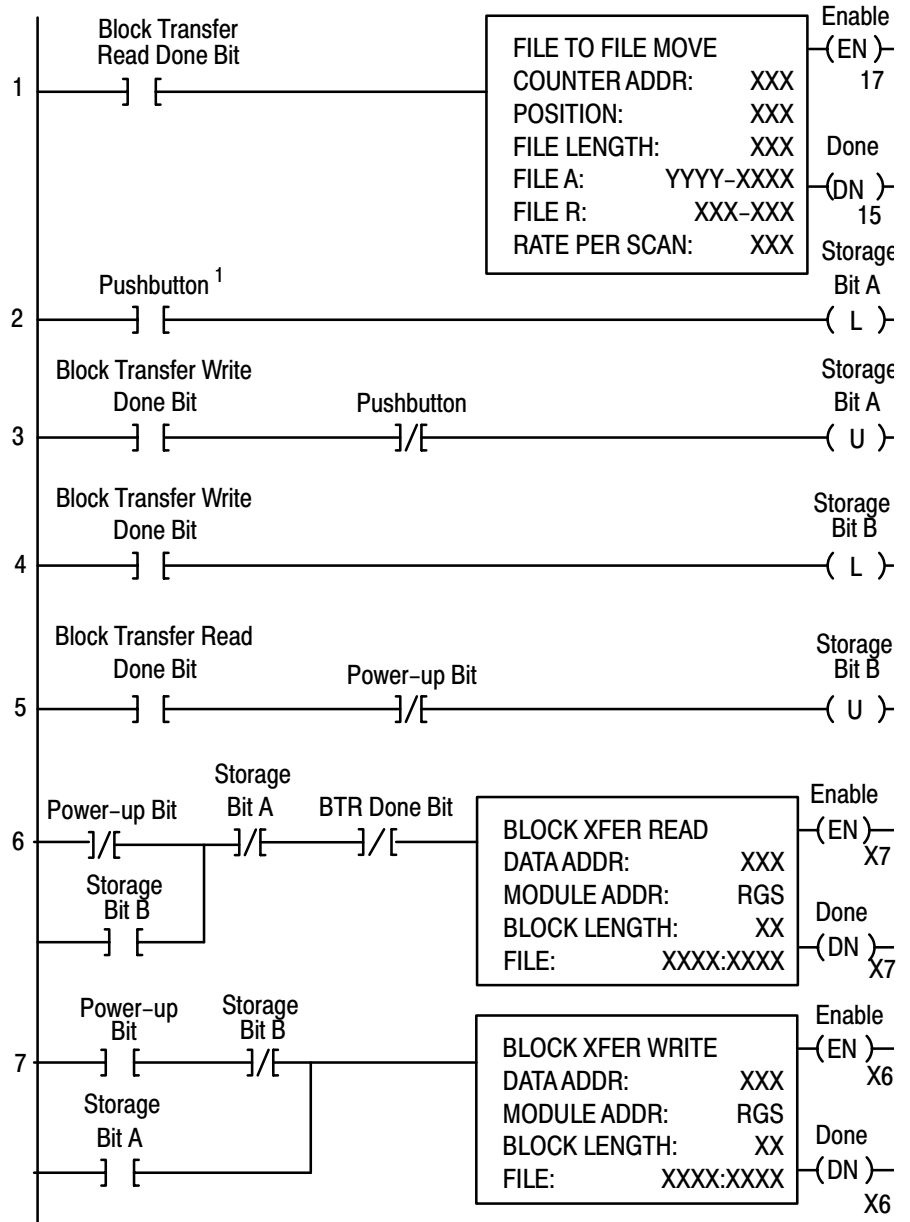

¹ You can replace the pushbutton with a timer "done" bit to initiate the block transfer write on a timed basis. You can also use any storage bit in memory.

Program Action

Rung 1 - Block transfer read buffer: the file-to-file move instruction holds the block transfer read (BTR) data (file A) until the processor checks the data integrity.

1. If the data was successfully transferred, the processor energizes the BTR done bit, initiating a data transfer to the buffer (file R) for use in the program.
2. If the data is corrupted during the BTR operation, the BTR done bit is not energized and data is not transferred to the buffer file. In this case, the data in the BTR file will be overwritten by data from the next BTR.

Rungs 2 and 3 - These rungs provide for a user-initiated block transfer write (BTW) after the module is initialized at power-up. Pressing the pushbutton locks out BTR operation and initiates a BTW that configures the module. Block transfer writes will continue for as long as the pushbutton remains closed.

Rungs 4 and 5 - These rungs provide a "read-write-read" sequence to the module at power-up. They also insure that only one block transfer (read or write) is enabled during a particular program scan.

Rungs 6 and 7 - These rungs are the conditioning block transfer rungs. Include all the input conditioning shown in the example program.

PLC-3 Program Example

Block transfer instructions with the PLC-3 processor use one binary file in a data table section for module location and other related data. This is the block transfer control file. The block transfer data file stores data that you want transferred to the module (when programming a block transfer write) or from the module (when programming a block transfer read). The address of the block transfer data files are stored in the block transfer control file.

The industrial terminal prompts you to create a control file when a block transfer instruction is being programmed. **The same block transfer control file is used for both the read and write instructions for your module.** A different block transfer control file is required for every module.

A sample program segment with block transfer instructions is shown in Figure 4.2, and described below.

Figure 4.2
PLC-3 Family Sample Program Structure

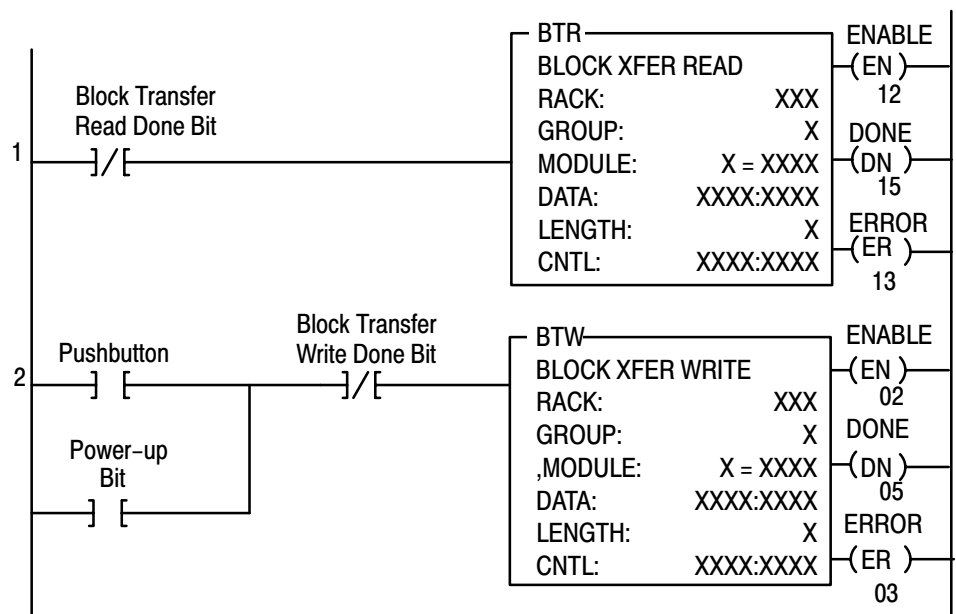

Program Action

At power-up, the user program examines the BTR done bit in the block transfer read file, initiates a write block transfer to configure the module, and then does consecutive read block transfers continuously. The power-up bit can be examined and used anywhere in the program.

Rungs 1 and 2 - Rungs 1 and 2 are the block transfer read and write instructions. The BTR enable bit in rung 1, being false, initiates the first read block transfer. After the first read block transfer, the module performs a block transfer write and then does continuous block transfer reads until the pushbutton is used to request another block transfer write.

After this single block transfer write is performed, the module returns to continuous block transfer reads automatically.

PLC-5 Program Example

The PLC-5 program is very similar to the PLC-3 program with the following exceptions:

- You must use enable bits instead of done bits as the conditions on each rung.
- A separate control file must be selected for each of the BT instructions. Refer to Appendix B.

Figure 4.3
PLC-5 Family Sample Program Structure

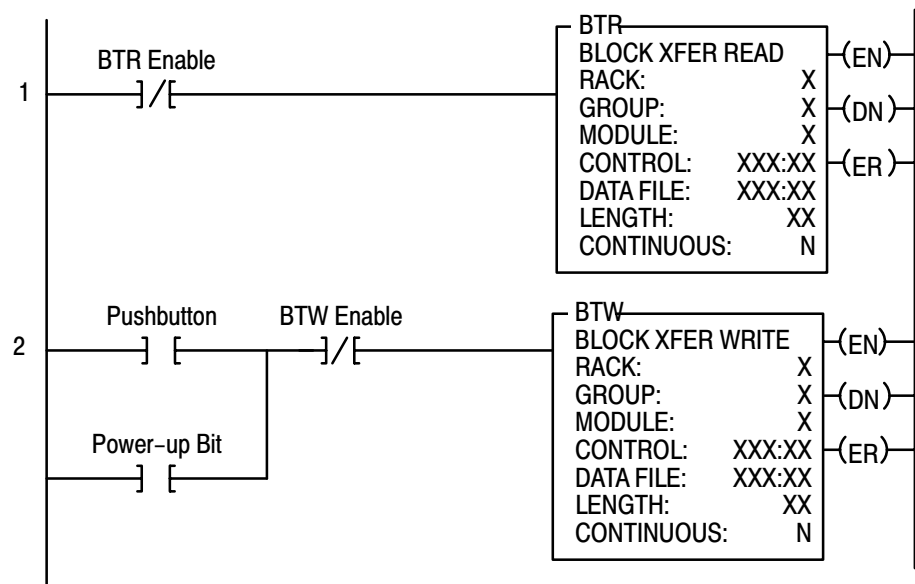

Program Action

Rungs 1 and 2 – At power-up, the program enables a block transfer read and examines the power-up bit in the BTR file (rung 1). Then, it initiates one block transfer write to configure the module (rung 2). Thereafter, the program continuously reads data from the module (rung 1).

A subsequent BTW operation is enabled by a pushbutton switch (rung 2). Changing processor mode will not initiate a block transfer write unless the first pass bit is added to the BTW input conditions.

Module Scan Time

Scan time is defined as the amount of time it takes for the input module to read the input channels and place new data into the data buffer. Scan time for your module is shown in Figure 4.4.

The following description references the sequence numbers in Figure 4.4.

Following a block transfer write “1” the module inhibits communication until after it has configured the data and loaded calibration constants “2”, scanned the inputs “3”, and filled the data buffer “4”. Write block transfers, therefore, should only be performed when the module is being configured or calibrated.

Any time after the second scan begins “5”, a BTR request “6” can be acknowledged.

When operated in real time sample mode (RTS) = 00, a BTR may occur at any time after “4.” When operated in RTS = T, a BTR will be waived until “T” milliseconds, at which time 1 BTR will be released.

Figure 4.4
Block Transfer Time

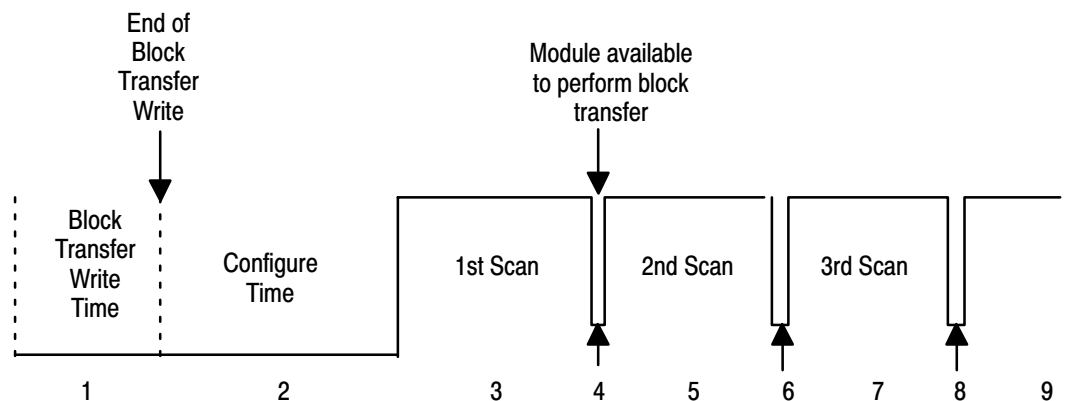

Internal Scan time = 50msec
T = 100ms, 200ms, 300ms ... 3.1sec.

Chapter Summary

In this chapter, you learned how to program your programmable controller. You were given sample programs for your PLC-2, PLC-3 and PLC-5 family processors.

You also read about module scan time.

Module Configuration

Chapter Objectives

In this chapter you will read how to configure your module's hardware, condition your inputs and enter your data.

Configuring Your RTD Module

Because of the many analog devices available and the wide variety of possible configurations, you must configure your module to conform to the analog device and specific application that you have chosen. Data is conditioned through a group of data table words that are transferred to the module using a block transfer write instruction.

You can configure the following features for the 1771-IR series B module:

- data format
- RTD type
- units of measure (°C, °F or ohms)
- real time sampling
- calibration
- bias

Configure your module for its intended operation by means of your programming terminal and write block transfers (BTW).

Note: Programmable controllers that use 6200 software programming tools can take advantage of the IOCONFIG utility to configure this module. IOCONFIG uses menu-based screens for configuration without having to set individual bits in particular locations. Refer to your 6200 software literature for details.

During normal operation, the processor transfers from 1 to 14 words to the module when you program a BTW instruction to the module's address. The BTW file contains configuration words, bias values, and calibration values that you enter for each channel. **When a block transfer length of 0 is programmed, the 1771-IR/B will respond with the Series A default of 14.**

Data Format

You must indicate what format will be used to read data from your module. Typically, BCD is selected with PLC-2 processors, and binary (also referred to as integer or decimal) is selected with PLC-3 and PLC-5 processors. See Table 5.A and Appendix C for details on Data Format.

Table 5.A
Selecting Format for Reading Data

Decimal Bit 10 Octal Bit 12	Decimal Bit 9 Octal Bit 11	Data Format
0	0	BCD
0	1	2's complement binary
1	0	Signed magnitude binary
1	1	Same as signed magnitude binary

RTD Type

The RTD input module accepts the following types of RTD inputs:

RTD	Temperature Range	Indication	Word 1, Bit 10	Ohms	°C	°F
Platinum	-200 to +870°C (-328 to 1598°F)	Underrange	0	1.00	-200	-328
		Overrange		600.00	870	1598
Copper	-200 to +260°C (-328 to 500°F)	Underrange	1	1.00	-200	-328
		Overrange		327.67	260	500

Units of Measure

The units of measure reported by the RTD module are selected by setting bits 06-07 in BTW word 1.

Units of Measure	Bit	
	07	06
Degrees C	0	0
Degrees F	0	1
Ohms	1	0
Not used	1	1

If any of bits 0-5 are set (1), the corresponding input channel will be reported in ohms.

Real Time Sampling

The real time sampling (RTS) mode of operation provides data from a fixed time period for use by the processor. RTS is invaluable for time based functions (such as PID and totalization) in the PLC. It allows accurate time based calculations in local or remote I/O racks.

In the RTS mode the module scans and updates its inputs at a user defined time interval (ΔT) instead of the default interval. The module ignores block transfer read (BTR) requests for data until the sample time period elapses. The BTR of a **particular data set** occurs only once at the end of the sample period and subsequent requests for transferred data are ignored by the module until a new data set is available. If a BTR does not occur before the end of the next RTS period, a time-out bit is set in the BTR status area. When set, this bit indicates that at least one data set was not transferred to the processor. (The actual number of data sets missed is unknown.) The time-out bit is reset at the completion of the BTR.

Set appropriate bits in the BTW data file to enable the RTS mode. You can select RTS periods ranging from 100 milliseconds (msec) to 3.1 seconds in increments of 100msec. Refer to Table 5.B below for actual bit settings. Note that the default mode of operation is implemented by placing all zeroes in bits 13 through 17. In default mode, the sample time period is 50msec, and the RTS time-out is inhibited. Note that binary representation of the RTS bit string is the RTS period X 100msec. For example, 900msec = 01001 = (9 X 100msec).

Table 5.B
Bit Settings for the Real Time Sample Mode

Decimal Bits Octal Bits	15 17	14 16	13 15	12 14	11 13	Sample Time Period
	0	0	0	0	0	RTS inhibited (50msec)
	0	0	0	0	1	100 ms
	0	0	0	1	0	200 ms
	0	0	0	1	1	300 ms
	0	0	1	0	0	400 ms
	0	0	1	0	1	500 ms
	0	0	1	1	0	600 ms
	0	0	1	1	1	700 ms
	0	1	0	0	0	800 ms
	0	1	0	0	1	900 ms
	0	1	0	1	0	1.0 sec
	0	1	1	1	1	1.5 sec
	1	0	1	0	0	2.0 sec
	1	1	0	0	1	2.5 sec
	1	1	1	1	0	3.0 sec
	1	1	1	1	1	3.1 sec

Important: Use decimally addressed bit locations for PLC-5 processors.

Configuring Block for a Block Transfer Write

The complete configuration block for the block transfer write to the module is defined in Table 5.C below.

Table 5.C
Configuration Block for RTD Input Module Block Transfer Write

Word	17	16	15	14	13	12	11	10	07	06	05	04	03	02	01	00
1	Sample Time (for RTS)				Data Format		RTD Type	Units of Measure		Single channel in ohms						
2	10 ohm resistance @ 25°C															
3	Channel 1 Bias															
4	Channel 2 Bias															
5	Channel 3 Bias															
6	Channel 4 Bias															
7	Channel 5 Bias															
8	Channel 6 Bias															
9	Channel 1 calibration															
10	Channel 2 calibration															
11	Channel 3 calibration															
12	Channel 4 calibration															
13	Channel 5 calibration															
14	Channel 6 calibration															
15	Auto-calibration request word															

Bit/Word Descriptions

Bit/word descriptions of BTW file words 1 (configuration), 2 (resistance value of 10 ohm copper RTDs), 3 through 8 (individual channel bias values) and 9 through 14 (individual channel calibration words) are presented below. Enter data into the BTW instruction after entering the instruction into your ladder diagram.

Table 5.D
Bit/Word Definitions for RTD Input Module

Word	Bits	Description				
Word 1	bits 00-05	If any of these bits are set, the corresponding input channel will be reported in ohms. If RTDs other than 10 ohm copper or 100 ohm platinum are used you must report those channels in ohms, not degrees. Data format on a channel displayed in ohms will default to binary.				
	bits 06-07	Determines what units of measure the module reports.				
		Units of measure	Bits	07	06	
		Degrees C		0	0	
		Degrees F		0	1	
		Ohms		1	0	
		Not used		1	1	
	bit 10	In temperature mode: 0 = Entire module is platinum 1 = Entire module is 10 ohm copper. Enter exact value in word 2. In ohms mode: 0 = 30mohm/count resolution 1 = 10mohm/count resolution				
	bits 11-12	Data format bits tell module which format to use for reporting input values to processor				
		Format	Bits	12	11	
4-digit BCD			0	0		
2's complement binary			0	1		
Signed magnitude (binary)			1	0		
	Not used		1	1		
bits 13-17	Real time sample bits. See Table 5.B.					
	Sample Time	17	16	15	14	13
	0.1	0	0	0	0	1
	0.5	0	0	1	0	1
	0.6	0	0	1	1	0
	0.7	0	0	1	1	1
	0.8	0	1	0	0	0
	0.9	0	1	0	0	1
	1.0	0	1	0	1	0

Word	Bits	Description
Word 1 (cont.)		1.5 0 1 1 1 1
		2.0 1 0 1 0 0
		2.5 1 1 0 0 1
		3.0 1 1 1 1 0
Word 2		If bit 10 is set in word 1, and temperature readings are desired, word 2 must also be used. Enter the exact resistance of 10 ohm RTD at 25°C in BCD. Range is 9.00 to 11.00 ohms. Values less than 9.00 ohms or greater than 11.00 ohms will default to 10.00 ohms. Non-BCD values will also default to 10.00 ohms.
Words 3–8		Individual channel bias words entered in BCD. This value is subtracted from the channel data in the BTR. The bias value is always a positive number. Bias value range is 0≤bias≤9999.
Words 9–14		Individual channel calibration words.
Word 15		Auto-calibration request word – used to automatically calibrate selected channels and save the calibration constants in EEPROM.
	Bit 00	Offset calibration complete
	Bit 01	Gain calibration complete
	Bit 02	Save complete
	Bit 06	EEPROM fault
	Bit 07	Faulty calibration (no save)
	Bits 10–15	Channel failed calibration

Default Configuration for the RTD Input Module

If zeroes are written to the module in all configuration positions, the module will default to:

- BCD format
- 100 ohm platinum RTD
- temperature in degrees C
- real time sampling = inhibited (sample time = 50msec)

Chapter Summary

In this chapter you learned how to configure your module’s hardware, condition your inputs and enter your data.

Module Status and Input Data

Chapter Objectives

In this chapter you will read about:

- reading data from your module
- input module read block format

Reading Data from the RTD Module

Block transfer read programming moves status and data from the input module to the processor's data table in one I/O scan (Table 6.A). The processor user program initiates the request to transfer data from the input module to the processor.

During normal operation, the read block transfer for this module moves up to 8 words from the RTD module in one program scan. The words contain module status and input data from each channel. **When a block transfer length of 0 is programmed, the 1771-IR/B will respond with the Series A default of 8 words.**

The user program initiates the request to transfer data from the RTD module to the processor.

Table 6.A
BTR Word Assignments for RTD Input Module (1771-IR/B)

Decimal Bit	15	14	13	12	11	10	9	8	7	6	5	4	3	2	1	0
Octal Bit	17	16	15	14	13	12	11	10	07	06	05	04	03	02	01	00
1	0	RTS Timeout	Channel Overrange					EEPROM calibration values not readable	Power- up	Channel Underrange						
2	Not used		Channel Polarity					Not used		Channel Overflow						
3	Channel 1 Data															
4	Channel 2 Data															
5	Channel 3 Data															
6	Channel 4 Data															
7	Channel 5 Data															
8	Channel 6 Data															
9	Auto-calibration Status Word															

Table 6.B
Bit/Word Description for RTD Input Module (1771-IR Series B)

Word	Bit	Definition
Word 1	Bits 00-05	Underrange indication for each channel; set when input is below the normal operating range for copper or platinum RTD. Bit 00 for input 1, bit 01 for input 2, etc. See Table 6.C.
	Bit 06	Power-up bit is set when the module is alive but not yet configured.
	Bit 07	EEPROM calibration values could not be read.
	Bits 10-15	Overrange bits are set when the input is above the normal operating range. Bit 10 for input 1, bit 11 for input 2, etc. See Table 6.C.
	Bit 16	Real time sample time-out bit. See page 5-2.
	Bit 17	Not used
Word 2	Bit 00-05	When set, indicates that default bias has been subtracted from the input value. Only the remainder is shown in the data word. Each bit relates to a single channel; bit 00 for input 1, etc. Default bias is automatically applied when BCD formatted data cannot be displayed. This will occur when measuring temperatures in Fahrenheit larger than 999.9 degrees. The default bias value which is subtracted is 1000.0.
	Bits 06-07	Not used
	Bits 10-15	Sign bits for each channel. When set indicate that a certain input is negative. Bit 10 corresponds to input 1, bit 11 to input 2, etc. These bits are used for BCD and signed magnitude data formats.
	Bits 16-17	Not used
Words 3-8		Input data words. The data words must be multiplied or divided by a factor if whole numbers need to be displayed.
		If you are reading temperature in °F or °C:
		Then there is an implied decimal point (XXX.X) after the least significant digit. Resolution is 0.1°.
		If you are reading resistance in milliohms (copper RTDs) (BTW word 1, bit 10 = 1):
		Then there is an implied decimal point (XXX.XX).
		If you are reading resistance in milliohms (all other RTDs) (BTW word 1, bit 10 = 0):
	Multiply the data word by 30 to get the actual value in milliohms. Resolution is 30 milliohms.	
Word 9		Auto-calibration word.
	Bit 00	Offset calibration complete
	Bit 01	Gain calibration complete
	Bit 02	Save complete
	Bit 06	EEPROM fault

Word	Bit	Definition
Word 9 (cont.)	Bit 07	Faulty calibration (no save)
	Bits 10-15	Channel failed calibration. Bit 10 for input 1, bit 11 for input 2, etc.

Table 6.C
Overrange and Underrange Values

Indication	BTW Word 1, Bit 10	RTD	Ohms	°C	°F
			< 1.00	< -200	< -328
Underrange	0	Platinum	> 600.00	> 870	> 1598
Overrange			< 1.00	< -200	< -328
Underrange	1	Copper	> 327.67	> 260	> 500
Overrange					

Chapter Summary

In this chapter you learned the meaning of the status information that the RTD input module sends to the processor.

Module Calibration

Chapter Objective

In this chapter we tell you how to calibrate your modules.

Tools and Equipment

In order to calibrate your input module you will need the following tools and equipment:

Tool or Equipment	Description	Model/Type	Available from:
Industrial Terminal and Interconnect Cable	Programming terminal for A-B family processors	Cat. No. 1770-T3 or Cat. No. 1784-T45, -T50, etc.	Allen-Bradley Company Highland Heights, OH
Precision Resistors	1.00 ohm, 1% (quantity of 6)	CMF-65-0010-F-T-0	Dale
	402.0 ohm, 0.01% (quantity of 6)	MAR6-T16-402-.01%	TRW

Calibrating your Input Module

You must calibrate the module in an I/O chassis. The module must communicate with the processor and industrial terminal.

Before calibrating your module, you must enter ladder logic into the processor memory, so that you can initiate BTWs to the module, and the processor can read inputs from the module.

Calibration can be accomplished using either of two methods:

- auto-calibration
- manual calibration

About Auto-calibration

Auto-calibration calibrates the input by generating offset and gain correction values and storing them in EEPROM. These values are read out of EEPROM and placed in RAM memory at initialization of the module.

The auto-calibration routine operates as follows:

- Whenever a block transfer write (BTW) is performed to the module (any time after the module has been powered up), it interrogates word 15 for a request for auto-calibration.
- The request can be for the following: offset calibration, gain calibration, save operation (save to EEPROM).

When using auto-calibration, write transfer calibration words 9 through 14 must contain zeroes.

Performing Auto-calibration

Calibration of the module consists of applying 1.00 ohm resistance across each input channel for offset calibration, and 402.00 ohm across each input channel for gain correction.

Offset Calibration

Normally all inputs are calibrated together. To calibrate the offset of an input, proceed as follows:

1. Connect 1.00 ohm resistors across each input channel as shown in Figure 7.1.

Figure 7.1
Resistor Location for Offset Calibration

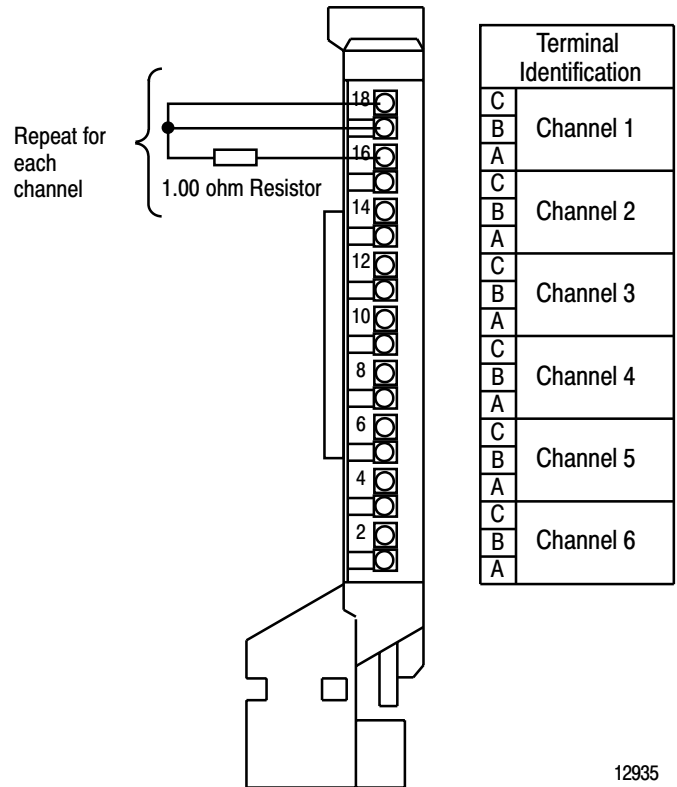

12935

2. Apply power to the module.
3. After the connections stabilize, request the offset calibration by setting bit 00 in block transfer write word 15 and sending a block transfer write to the module. Refer to Table 7.A.

Table 7.A
Write Block Transfer Word 15

Word Bit	17	16	15	14	13	12	11	10	07	06	05	04	03	02	01	00
Word 15	Inhibit Calibration on Channel								Requested Auto-Calibration							
	Set these bits to 0	6	5	4	3	2	1	Set these bits to 0			Requested Save Values	Requested Gain Cal.	Requested Offset Cal.			

NOTE: Normally, all channels are calibrated simultaneously (bits 10–15 of word 15 are octal 0). To disable calibration on any channel, set (1) the corresponding bit 10 through 15 of word 15.

- Queue block transfer reads (BTRs) to monitor for offset calibration complete and any channels which may have not calibrated successfully. Refer to Table 7.B.

Table 7.B
Read Block Transfer Word 9

Word Bit	17	16	15	14	13	12	11	10	07	06	05	04	03	02	01	00
Word 9	Uncalibrated Channels								Auto-Calibration Status							
	Not used	6	5	4	3	2	1	Cal. Fault	EEPROM Fault	Not used			Save to EEPROM Complete	Gain Cal. Complete	Offset Cal. Complete	

- Proceed to gain calibration below.

Gain Calibration

Calibrating gain requires that you apply 402.00 ohms across each input channel.

Normally all inputs are calibrated together. To calibrate the gain of an input, proceed as follows:

- Connect 402.00 ohm resistors across each input channel as shown in Figure 7.2.

Figure 7.2
Resistor Location for Gain Calibration

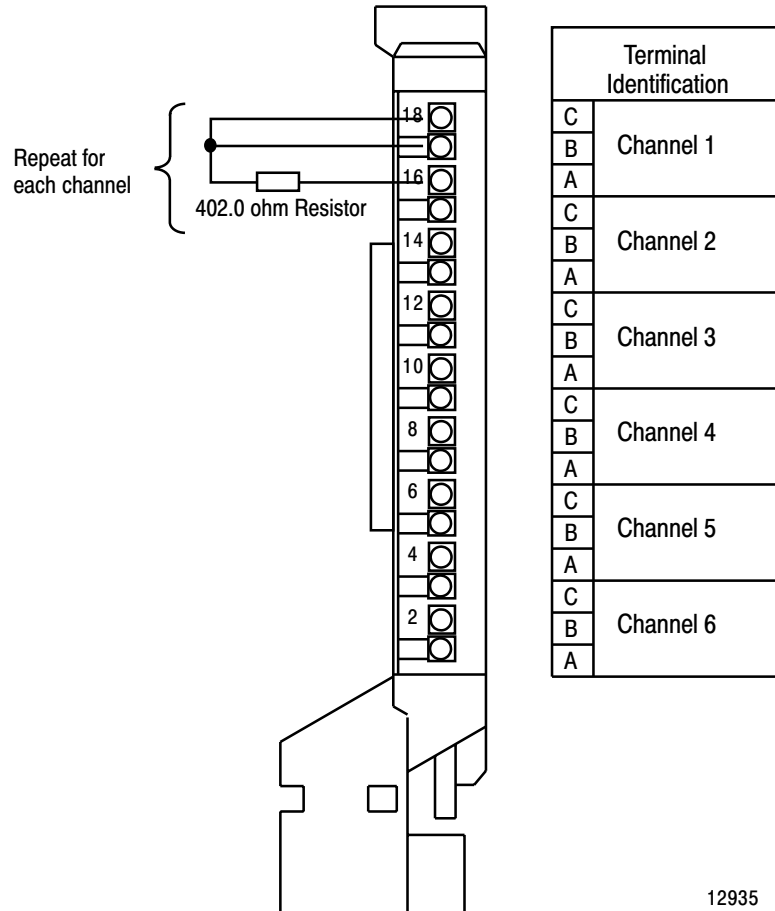

12935

2. Apply power to the module.
3. After the connections stabilize, request the gain calibration by setting bit 01 in BTW word 15 and sending a block transfer write (BTW) to the module. Refer to Table 7.A.

NOTE: Normally, all channels are calibrated simultaneously (bits 10–15 of word 15 are octal 0). To disable calibration on any channel, set (1) the corresponding bit 10 through 15 of word 15.

4. Queue BTRs to monitor for gain calibration complete and channels which may not have calibrated successfully.

Save Calibration Values

If any "uncalibrated channel" bits (bits 10–15 of BTR word 9) are set, a save cannot occur. Auto-calibration should be performed again, starting with offset calibration. If the module has a faulty channel, the remaining functioning channels can be calibrated by inhibiting calibration on the faulty channel.

The module can be run with the new calibration values, but will lose them on power down. To save these values, proceed as follows:

1. Request a "save to EEPROM" by setting bit 02 in BTW word 15 and sending the BTW to the module. Refer to Table 7.A.
2. Queue BTRs to monitor for "save complete", "EEPROM fault" and "calibration fault." An EEPROM fault indicates a nonoperative EEPROM; a calibration fault indicates at least one channel was not properly offset or gain calibrated and a save did not occur.

Note: During normal operation, make sure bits 00, 01 and 02 of BTW word 15 are zero (0).

Performing Manual Calibration

You calibrate each channel by applying a precision resistance across each channel, comparing correct with actual results, and entering correction into the corresponding calibration word for that channel. The correction takes affect after it is transferred to the module by the corresponding BTW instruction in your ladder diagram program. Always start with offset adjustment followed by gain adjustment.

Before calibrating the module, you must enter ladder logic into processor memory, so that you can initiate write block transfers to the module, and the processor can read inputs from the module.

Words 9 through 14 in the write block transfer file are the module calibration words. Word 9 corresponds to channel 1, word 10 to channel 2, and so on. Each word is composed of two bytes: the upper byte is for offset correction and the lower byte is for gain correction. Refer to Table 7.C.

Table 7.C
Module Calibration Words

Word/Bit	17	16	15	14	13	12	11	10	07	06	05	04	03	02	01	00
9	S	Channel 1 Offset							S	Channel 1 Gain						
10	S	Channel 2 Offset							S	Channel 2 Gain						
11	S	Channel 3 Offset							S	Channel 3 Gain						
12	S	Channel 4 Offset							S	Channel 4 Gain						
13	S	Channel 5 Offset							S	Channel 5 Gain						
14	S	Channel 6 Offset							S	Channel 6 Gain						

Enter the information for each byte in signed magnitude binary format. In each byte, the most significant bit (bits 17, 7) is a polarity bit. When the polarity bit is set (1), the module anticipates a negative calibration value.

A negative calibration value means that your readings are too high and you want to **subtract** a corrective amount from that reading.

A positive calibration value means that your readings are too low and you want to **add** a corrective amount to that reading.

Important: If you have a spare field wiring arm, you may want to temporarily switch it with the module's present wiring arm. You can use this spare arm for test purposes in order to avoid disconnecting your RTD wiring.

Offset Calibration

1. Attach the 1.00 ohm, 1% resistors as shown in Figure 7.1.
2. Examine word 3 (channel 1 data) in the read block transfer file. Note the value. It should be around 1.00 (100 for 10 mohm resolution; 33 for 30 mohm resolution).
3. Examine word 9 of the write block transfer data file. Bits 16–10 make up the offset correction byte. Bit 17 is the sign bit.
4. Subtract the data value that you noted in step 2 from 100. The difference should be within +127 to –127. If it is not, the required correction is beyond the range of software calibration. If the difference is within range, input the difference (positive or negative), in binary form, in bits 17–10 of word 9 in the write block transfer file.

For example, if, at 1.00 ohm, word 3 of the read block transfer data file shows 147, you would subtract 147 from 100, which equals –47. You would then enter 10101111 (–47) in the upper byte of word 9. The leading 1 (bit 17) is the polarity bit. It indicates a negative correction factor. That

is, you want to subtract 47 counts from your input data. The lower byte remains 00 during offset calibration.

5. Repeat above steps for channels 2 through 6 respectively.
6. Apply the values by sending a BTW to the module.

Gain Calibration

1. Connect the 402.00, .01% resistors to the swing arm as shown in Figure 7.2.
2. Place the module in platinum ohm mode. This provides 30 mohm resolution display.
3. Examine word 3 of the read block transfer data file. It should be around 13400 decimal. Your actual value will be a percentage of 13400.

For example, if the data in word 3 is 13408, then:

$$(13400-13408)/134000 = -0.000597.$$

Your actual data value differs from the theoretical value (at 402.0 ohms input resistance) by -0.000597 , or -0.0597% .

You can compensate for this error by entering the percentage difference in binary coded fraction form. Table 7.D lists the value for bits 7-0.

Table 7.D
Value for Bits 7 through 0

Bit	Value
Bit 07	Sign bit
Bit 06	= 0.0976562%
Bit 05	= 0.0488281%
Bit 04	= 0.024414%
Bit 03	= 0.012207%
Bit 02	= 0.00610351%
Bit 01	= 0.00305175%
Bit 00	= 0.00152587%

You use the values that most nearly add up to the percentage that you determined in step 8. For example, to attain the value of 0.0597%, you need to add:

Percentage	Bit Number
0.0488281	Bit 05
0.00610351	Bit 02
0.00305175	Bit 01
0.00152587	Bit 00
Total = 0.0595%	

As you can see, 0.0595 is smaller than 0.0597, but this value is as close as you can come using the 7 possible values listed in Table 7.D.

You would enter 10100111 in the lower byte of word 9. This sets bits 05, 02, 01 and 00, which subtracts a gain correction of 0.0595% from the actual input data value.

Important: When you enter data in the least significant byte, remember to reenter the data in the most significant byte in the word. If you don't, the data in the MSB is lost.

4. Repeat above steps for channels 2 through 6.
5. Apply the values by sending a BTW to the module.

Chapter Summary

In this chapter, you learned how to calibrate your input module.

Troubleshooting

Chapter Objective

We describe how to troubleshoot your module by observing LED indicators and by monitoring status bits reported to the processor.

Diagnostics Reported by the Module

At power-up, the module momentarily turns on both indicators as a lamp test, then checks for

- correct RAM operation
- EPROM operation
- EEPROM operation
- a valid write block transfer with configuration data

Thereafter, the module lights the green RUN indicator when operating without fault, or lights the red fault (FLT) indicator when it detects fault conditions. If the red FLT indicator is on, block transfer will be inhibited.

The module also reports status and specific faults (if they occur) in every transfer of data to the PC processor. Monitor the green and red LED indicators and status bits in word 1 of the BTR file when troubleshooting your module.

Figure 8.1
LED Indicators

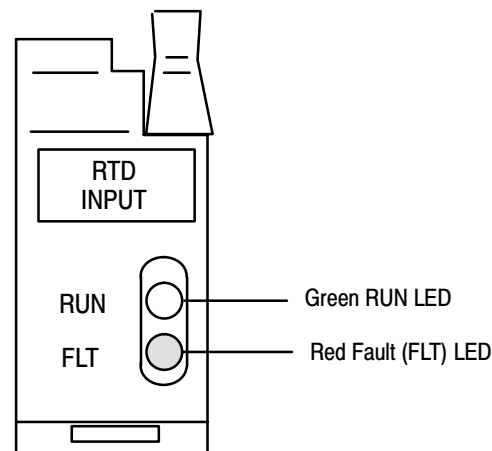

This module uses a read block transfer to transmit data and to monitor module and data status. Word 1 of the read block transfer data file contains module status, power-up, and data out-of-range information. Word 2 contains data polarity and overflow information. Words 3 through 8 are data words.

Table 8.A shows LED indications and probable causes and recommended actions to correct common faults.

Table 8.A
Troubleshooting Chart for the RTD Input Module (1771-IR/B)

Indication	Probable Cause	Recommended Action
Both LEDs are OFF	No power to module Possible short on the module LED driver failure	Check power to I/O chassis. Recycle as necessary. Replace module.
Red FLT LED ON and Green RUN LED is ON	Microprocessor, oscillator or EPROM failure	Replace module.
Red FLT LED ON	If immediately after power-up, indicates RAM or EPROM failure. ¹	Replace module.
	If during operation, indicates possible microprocessor or backplane interface failure. ¹	Replace module.
Green RUN LED is flashing	Power-up diagnostics successfully completed.	Normal operation.
	If LED continues to flash, and write block transfers (BTW) cannot be accomplished, you have a possible interface failure.	Check ladder logic program. If correct, replace module.

¹ When red LED is on, the watchdog timer has timed out and backplane communications are terminated. Your user program should monitor communication.

Status Reported in Words 1 and 2

Design your program to monitor status bits in words 1 and 2, and to take appropriate action depending on your application requirements. You may also want to monitor these bits while troubleshooting with your industrial terminal. The module sets a bit (1) to indicate it has detected one or more of the following conditions.

Table 8.B
Status Reported in Words 1 and 2

Word	Bit	Indication
1	00-05	Data underrange. Bit 05 corresponds to channel 6, bit 04 corresponds to channel 5, and so on. If input connections and resistances are correct, this status may indicate failed communications between the channel and microprocessor. If all channels are underrange, a blown fuse or failed dc-dc converter may be the cause.
	06	Successful power-up and module is waiting for configuration data. Bit 06 is reset after the first successful block transfer write.
	07	EEPROM calibration constants could not be read. The module will continue to operate but readings may be inaccurate.

Word	Bit	Indication
Word 1 (cont.)	10-15	Data overrange. Bit 15 corresponds to channel 6, bit 14 corresponds to channel 5, and so on. If input connections and resistances are correct, this status may indicate a failed RTD functional analog block (RTD FAB).
	16	RTS timed out. The module updated its inputs before the processor read them.
	17	Not used.
2	00-05	Indicates that the default bias of 1000.0 has been subtracted from the measured value. If sending binary data, no overflow occurs unless there is a hardware malfunction.
	06-07	Not used
	10-15	Data sign bits formatted for BCD or signed magnitude. Bit 10 corresponds to channel 1, bit 11 to channel 2, and so on.
	16-17	Not used

Status Reported in Word 9

Design your program to monitor status bits in word 9 during calibration, and to take appropriate action depending on your requirements. You may also want to monitor these bits while troubleshooting with your industrial terminal. The module sets a bit (1) to indicate it has detected one or more of the following conditions.

Table 8.C
Status Reported in Word 13

Word	Bit	Condition
9	6	The EEPROM could not be written.
	7	Channel(s) could not be calibrated as indicated by bits 10 through 15 respectively.
	10-15	Bit 10 (channel 1) through bit 16 (channel 6) could not be calibrated. Check field wiring arm connections and source for proper resistance.

Chapter Summary

In this chapter, you learned how to interpret the LED status indicators and troubleshoot your input module.

Specifications

Module Capacity	Six RTD input channels
Module Location	1771 I/O Chassis
Sensor Type	100 ohm platinum (alpha = 0.00385) or 10 ohm copper (alpha = 0.00386) Other types may be used with report in ohms only
Units of measure	Temperature in °C Temperature in °F RTD resistance in ohms (10milliohms or 30milliohms resolution)
Temperature Range	Platinum: -200 to +870°C (-328 to 1598°F) Copper: -200 to +260°C (-328 to +500°F)
Resistance Range	1.00 to 600.00 ohms
Resolution	Platinum: 0.1°C (0.1°F) Copper: 0.3°C (0.5°F)
Sensor Excitation	1mA constant current source supplied by module
Input Isolation Dielectric Test	1000V peak channel to channel, channel to backplane, for 1 second
Common Mode Rejection	120db @ 60Hz up to 1000V peak
Common Mode Impedance	Greater than 10 megohms
Normal Mode Rejection	60db @ 60Hz
Input Overvoltage Protection	120V rms continuous
Open RTD Response Time	Open excitation (terminal A) to overrange: <0.5sec Open common (terminal C) to underrange: <0.5sec Open sense (terminal B): drift high
Scan Time (all 6 channels)	50ms
Environmental Conditions	
Operating Temperature	0 to 60°C (32 to 140°F)
Rate of Change	Ambient changes greater than 1.0°C/minute may temporarily degrade performance during periods of change.
Storage Temperature	-40 to 85°C (-40 to 185°F)
Relative Humidity	5 to 95% noncondensing
Backplane Power Consumption	4.25W maximum, 0.85A at 5V
Keying	Between 10 and 12 Between 28 and 30
Field Wiring Arm	Cat. No. 1771-WF

Table A.A
1771-IR Series B Error Summary Based on Temperatures above -200°C

RTD Type	Range	Error @ Calibration Temperature (25°C) (over range)	Drift °C/°C or °F/°F
Copper	-200 to +260°C (-328 to +500°F)	±0.344°C/±0.564°F	±0.1306
Platinum	-200 to +870°C (-328 to 1598°F)	±0.100°C/±0.152°F	±0.0717

Table A.B
1771-IR Series B Resistance Error Summary

RTD Type	Resistance Error @ 25°C (over range)	Resistance Drift Ohm/°C
Copper	±0.074 ohm	±0.0213
Platinum	±0.075 ohm	±0.0213

Programming Examples

Sample Programs for the RTD Input Module

The following are sample programs for entering data in the configuration words of the write block transfer instruction when using the PLC-2, PLC-3 or PLC-5 family processors.

PLC-2 Family Processors

To enter data in the configuration words, follow these steps. NOTE: For complete programming sample, refer to Figure 4.1.

Example:

Enter the following rung for a write block transfer:

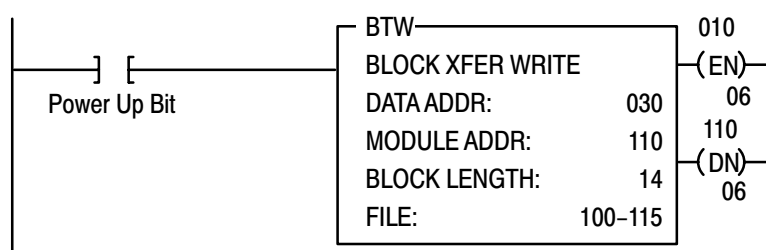

100 is the address of the write block transfer data file. You want to examine configuration word 1.

In RUN/PROG Mode

Action	Result
1. Press [SEARCH]8<data address>	Finds the block address transfer instruction
2. Press CANCEL COMMAND	Removes preceding command
3. Press [DISPLAY]0 or 1	Displays the file in binary or BCD
4. Press [SEARCH]51 Cursor defaults to first entry in file when SEARCH 51 is pressed.	On line data change
5. Press [INSERT]	Writes data to file element

In PROG Mode

Action	Result
1. Press [SEARCH]8<data address>	Finds the block transfer instruction
2. Press CANCEL COMMAND	Removes preceeding command
3. Press [DISPLAY]0 or 1	Displays the file in binary or BCD
4. Press [DISPLAY]001 and enter data	Puts cursor on word 1
5. Press [INSERT]	

Use the above procedure to enter the required words of the write block transfer instruction. Be aware that the block length will depend on the number of channels selected and whether biasing and/or calibration is or is not performed; for example, the block may contain only 1 word if no bias or calibration is performed but may contain 14 words if using 6 inputs with bias and calibration. The PLC-2 family write block transfer data file should look like Figure B.1.

Figure B.1
Write Block Transfer Data Transfer for a PLC-2 Family Processor

POSITION	FILE DATA			
001	00000000	00000000	00000000	00000000
002	00000000	00000000	00000000	00000000
003	00000000	00000000	00000000	00000000
004	00000000	00000000	00000000	00000000
005	00000000	00000000	00000000	00000000
006	00000000	00000000	00000000	00000000
007	00000000	00000000	00000000	00000000
008	00000000	00000000	00000000	00000000

PLC-3 Family Processors

Following is a sample procedure for entering data in the configuration words of the write block transfer instruction when using a PLC-3 processor. For a complete sample program, refer to Figure 4.2.

To enter data in the configuration words, follow these steps:

Example:

Enter the following rung for a write block transfer:

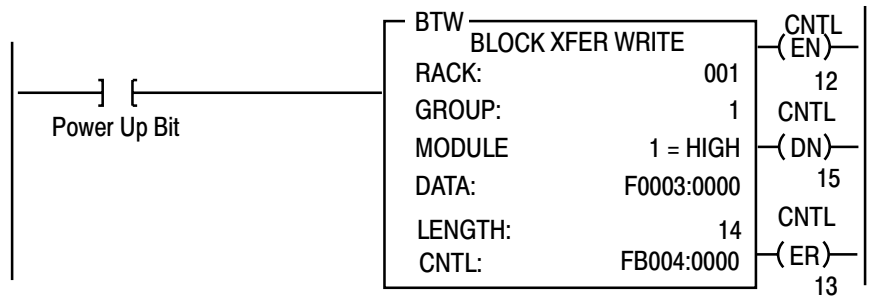

F0003:0000 is the address of the write block transfer data file. You want to enter/examine word 1.

1. Press [SHIFT][MODE] to display your ladder diagram on the industrial terminal.
2. Press DD,03:0[ENTER] to display the block transfer write file.

The industrial terminal screen should look like Figure B.2. Notice the highlighted block of zeroes. This highlighted block is the cursor. It should be in the same place as it appears in figure B.2. If it is not, you can move it to the desired position with the cursor control keys. Once you have the highlighted cursor in the right place, you can go on to step 3.

3. Enter the data corresponding to your bit selection in word 0.
4. When you have entered your data, press [ENTER]. If you make a mistake, make sure the cursor is over the word you desire to change. Enter the correct data and press [ENTER].

Figure B.2
Write Block Transfer for a PLC-3 Processor

START - W0003 : 0000							
WORD #	0	1	2	3	4	5	6
00000	00000000	00000000	00000000	00000000	00000000	00000000	00000000
00004	00000000	00000000	00000000	00000000	00000000	00000000	00000000
00010	00000000	00000000	00000000	00000000	00000000	00000000	00000000
00014	00000000	00000000	00000000	00000000	00000000	00000000	00000000
00020	00000000	00000000	00000000	00000000	00000000	00000000	00000000

DATA MONITOR \$ W03:0 - []

PROG : I/O OFF NO FORCES : NO EDITS : RUNG # [RM000000] : MEM PROT OFF

5. Press [CANCEL COMMAND]. This returns you to the ladder diagram.

PLC-5 Family Processors

The following is a sample procedure for entering data in the configuration words of the block transfer write instruction when using a PLC-5 processor. For a complete sample program, refer to Figure 4.3.

1. Enter the following rung:

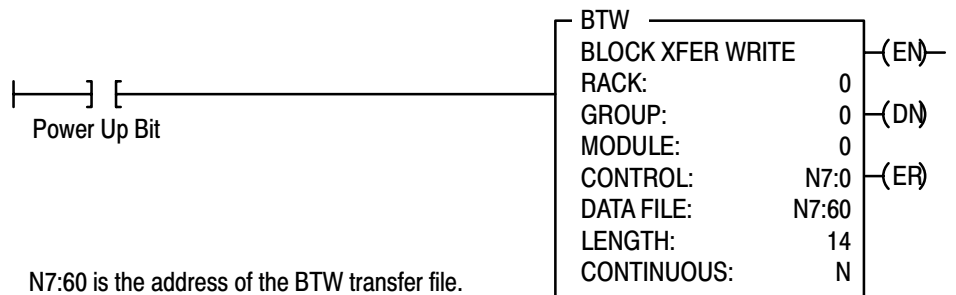

2. Press [F8],[F5] and enter N7:60 to display the configuration block.

The industrial terminal screen should like figure B.3.

Figure B.3
Sample PLC-5 Data File (Hexidecimal Data)

Address	0	1	2	3	4	5	6	7	8	9
N7:60	5141	0976	0150	0150	0150	0150	0150	0150	0000	0000
N7:70	0000	0000	0000	0000						

The above data file would configure the module as follow:

- copper RTDs on all inputs
 - temperature scale of Fahrenheit
 - channel 1 displayed in ohms
 - output data in BCD format
 - real time sampling set to a 1 second scan rate
 - copper RTD at 25°C is 9.76 ohms
 - all bias values set to subtract 0150
 - all calibration values set to 0
3. Enter the data corresponding to your bit selections.
 4. [ESC] returns you to the main menu.

Table C.A
BCD Representation

2^3 (8)	Place Value			Decimal Equivalent
	2^2 (4)	2^1 (2)	2^0 (1)	
0	0	0	0	0
0	0	0	1	1
0	0	1	0	2
0	0	1	1	3
0	1	0	0	4
0	1	0	1	5
0	1	1	0	6
0	1	1	1	7
1	0	0	0	8
1	0	0	1	9

Signed–magnitude Binary

Signed–magnitude binary is a means of communicating numbers to your processor. It should be used with the PLC–2 family when performing computations in the processor. It cannot be used to manipulate binary 12–bit values or negative values.

Example: The following binary number is equal to decimal 22.

$$10110_2 = 22_{10}$$

The signed–magnitude method places an extra bit (sign bit) in the left–most position and lets this bit determine whether the number is positive or negative. The number is positive if the sign bit is 0 and negative if the sign bit is 1. Using the signed magnitude method:

$$0\ 10110 = +22$$

$$1\ 10110 = -22$$

Two's Complement Binary

Two's complement binary is used with PLC-3 processors when performing mathematical calculations internal to the processor. To complement a number means to change it to a negative number. For example, the following binary number is equal to decimal 22.

$$10110_2 = 22_{10}$$

First, the two's complement method places an extra bit (sign bit) in the left-most position, and lets this bit determine whether the number is positive or negative. The number is positive if the sign bit is 0 and negative if the sign bit is 1. Using the complement method:

$$0\ 10110 = 22$$

To get the negative using the two's complement method, you must invert each bit from right to left after the first "1" is detected.

In the above example:

$$0\ 10110 = +22$$

Its two's complement would be:

$$1\ 01010 = -22$$

Note that in the above representation for +22, starting from the right, the first digit is a 0 so it is not inverted; the second digit is a 1 so it is not inverted. All digits after this one are inverted.

If a negative number is given in two's complement, its complement (a positive number) is found in the same way:

$$1\ 10010 = -14$$

$$0\ 01110 = +14$$

All bits from right to left are inverted after the first "1" is detected.

The two's complement of 0 is not found, since no first "1" is ever encountered in the number. The two's complement of 0 then is still 0.

Block Transfer (Mini-PLC-2 and PLC-2/20 Processors)

Multiple GET Instructions – Mini-PLC-2 and PLC-2/20 Processors

Programming multiple GET instructions is similar to block format instructions programmed for other PLC-2 family processors. The data table maps are identical, and the way information is addressed and stored in processor memory is the same. The only difference is in how you set up block transfer read instructions in your program.

For multiple GET instructions, individual rungs of ladder logic are used instead of a single rung with a block transfer instruction. A sample rung using multiple GET instructions is shown in Figure D.1 and described in the following paragraphs.

Rung 1: This rung is used to set four conditions.

- **Examine On Instruction (113/02)** – This is an optional instruction. When used, block transfers will only be initiated when a certain action takes place. If you do not use this instruction, block transfers will be initiated every I/O scan.
- **First GET Instruction (030/120)** – identifies the module's physical address (120) by rack, group and slot; and where in the accumulated area of the data table this data is to be stored (030).
- **Second GET Instruction (130/060)** – indicates the address of the first word of the file (060) that designates where the data will be transferred. The file address is stored in word 130, 100₈ above the data address.
- **Output Energize Instruction (012/07)** – enables the block transfer read operation. If all conditions of the rung are true, the block transfer read enable bit (07) is set in the output image data table control byte. The output image table control byte contains the read enable bit and the number of words to be transferred. The output energize instruction is defined as follows:
 - "0" indicates that it is an output instruction
 - "1" indicates the I/O rack address
 - "2" indicates the module group location within the rack
 - "07" indicates this is a block transfer read operation (if this were a block transfer write operation, "07" would be replaced by "06".)

Rungs 2 and 3: These output energize instructions (012/01 and 012/02) define the number of words to be transferred. This is accomplished by setting a binary bit pattern in the module's output image table control byte. The binary bit pattern used (bits 01 and 02 energized) is equivalent to 6 words or channels, and is expressed as 110 in binary notation.

Rung Summary: Once the block transfer read operation is complete, the processor automatically sets bit 07 in the input image table status byte and stores the block length of the data transferred.

Figure D.1
Multiple GET Instructions (Mini-PLC-2 and PLC-2/20 Processors Only)

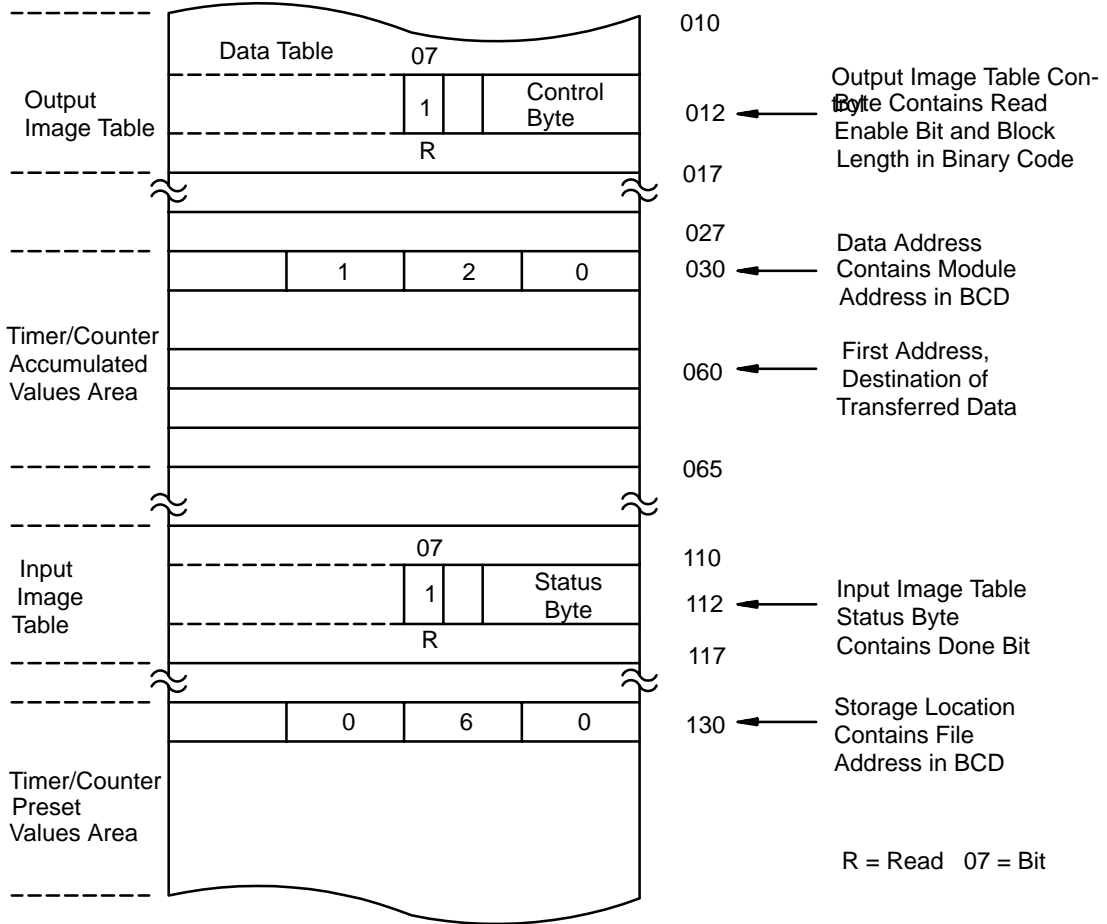

Multiple GET Instructions

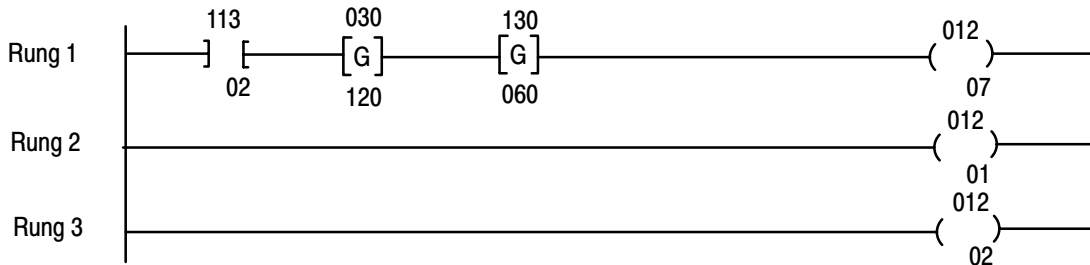

12172

**Setting the Block Length
(Multiple GET Instructions
only)**

The input module transfers a specific number of words in one block length. The number of words transferred is determined by the block length entered in the output image table control byte corresponding to the module's address.

The bits in the output image table control byte (bits 00 – 05) must be programmed to specify a binary value equal to the number of words to be transferred.

For example, Figure D.2 shows if your input module is set up to transfer 6 words, you would set bits 01 and 02 of the lower image table control byte. The binary equivalent of 6 words is 000110. You would also set bit 07 when programming the module for block transfer read operations. Bit 06 is used when block transfer write operations are required.

Figure D.2
Setting Block Length (Multiple GET Instructions only)

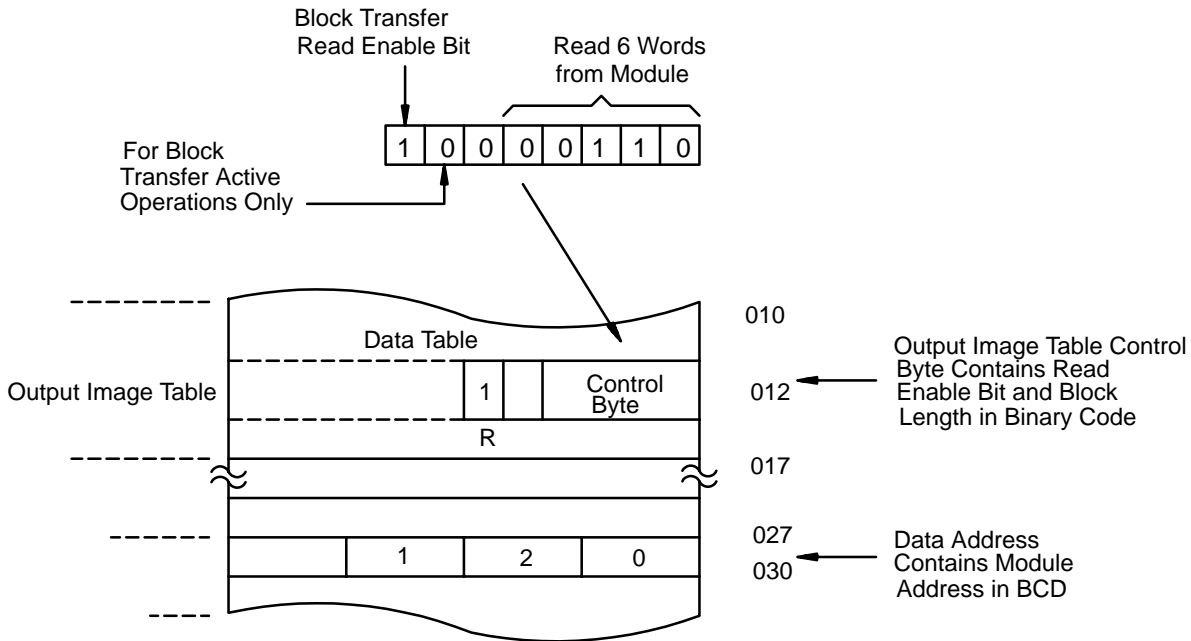

Number of Words to Transfer	Binary Bit Pattern Lower Output Image Table Byte					
	05	04	03	02	01	00
Default	0	0	0	0	0	0
1	0	0	0	0	0	1
2	0	0	0	0	1	0
3	0	0	0	0	1	1
4	0	0	0	1	0	0
5	0	0	0	1	0	1
6	0	0	0	1	1	0
	:			:		
18	0	1	0	0	1	0
19	0	1	0	0	1	1

2 and 4-Wire RTD Sensors

About 2 and 4-Wire Sensors

You can connect 2-wire and 4-wire sensors to the RTD module. Before we show you how to do this, let's examine the differences between 2, 3 and 4-wire sensors.

A 2-wire sensor is composed of just that; a sensor and 2 lead wires. Its schematic representation is shown in Figure E.1.

Figure E.1
Connections for a 2-Wire Sensor

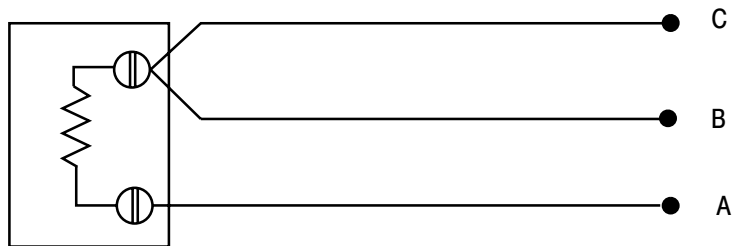

12950-1

A sensor requires at least three leads to compensate for lead resistance error, that is, an error caused by resistance mismatch between the lead wires.

Therefore, a 2-wire sensor cannot provide compensation for error caused by lead wire resistance. We do not recommend that you use 2-wire sensors.

Three-wire and 4-wire sensors compensate for lead resistance error. Their schematic representation is shown in Figure E.2. The amount of error elimination depends upon the difference between the resistance values of the lead wires. The closer the resistance values are to each other, the greater the amount of error that is eliminated.

Figure E.2
Connections for 3 and 4-Wire Sensors

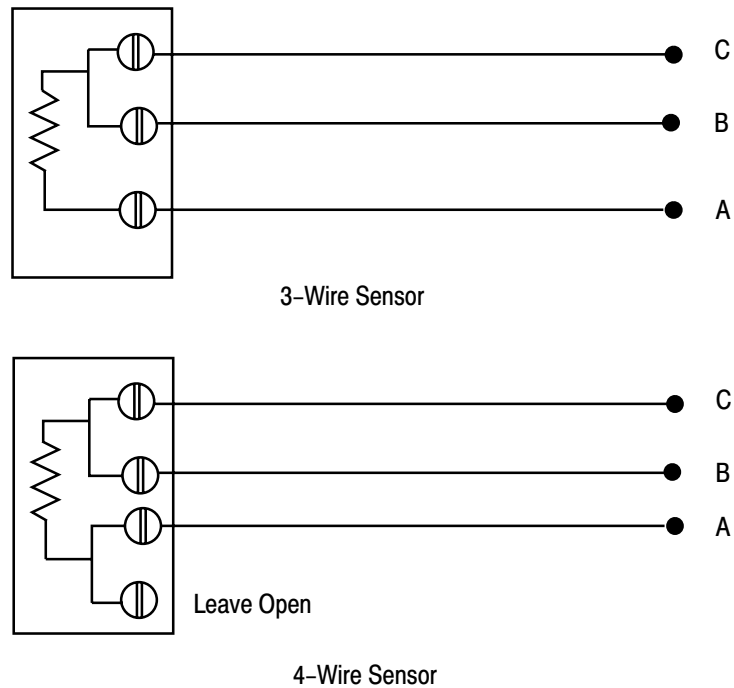

There are several ways to insure that the lead resistance values match as closely as possible. They are:

- use heavy gauge wire (16–18 gauge)
- keep lead distances less than 1000 feet
- use quality cable that has a small tolerance impedance rating.

Connecting 4-Wire Sensors

Figure E.3 shows how to connect 4-wire sensors to the field wiring arm of the RTD Input module. A 4-wire sensor has two pairs of leads; one pair for each resistor junction. One wire of the 4 is not used (it does not matter which one). This leaves 3 wires – one pair and one single wire. You must connect the single wire to the terminal marked "A". You connect the remaining pair of wires to terminals "B" and "C". It doesn't matter which wire of the pair connects to terminal "B" and which wire connects to terminal "C" so long as all 3 wires are the same AWG gauge.

Figure E.3
Connecting a 4-Wire Sensor to the Field Wiring Arm

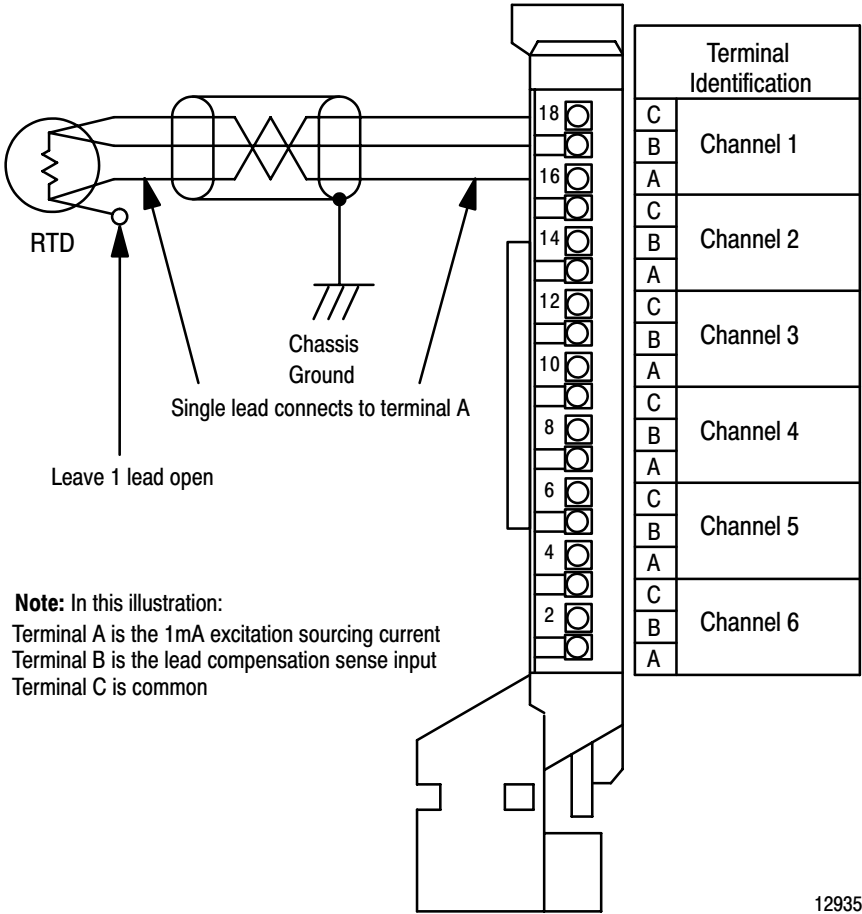

Note: In this illustration:
 Terminal A is the 1mA excitation sourcing current
 Terminal B is the lead compensation sense input
 Terminal C is common

12935-I

Differences Between Series A and Series B RTD Input Modules

Major Differences between Series

The following is a list of major changes from Series A to Series B RTD Input Module (cat. no. 1771-IR).

- The customer applied “10 ohm resistance value @ 0°C” is now “10 ohm resistance value @ 25°C” with a range of 9.00 to 11.00 ohms.
- Calibration is now done automatically using the auto-calibration feature, or manually through programming.
- Auto-calibration is done at 1.00 ohm and 402.0 ohms. Manual software calibration is done at 1.00 and 402.00 ohms (not 18.83 and 375.61 ohms). The module should be configured for platinum ohms display, not temperature, during the calibration procedure.
- If EEPROM read of the auto-calibration values fails, BTR WORD 1 bit 7 is asserted.
- RTS can be reduced to 100ms by programming $RTS = 1$.
- The default RTS setting at power up is inhibited and data is available every 50ms for Series B (was 300ms for Series A).
- Backplane power is approximately 0.85A at 5V. Series A was 1.0A at 5V.
- Accuracy specifications over RANGE and TEMPERATURE are:
 - Typical
 - Copper = $\pm 4.91^{\circ}\text{C}$
 - Platinum = $\pm 2.60^{\circ}\text{C}$
 - OHM = ± 0.82 Ohms
- User offset calibration range is ± 1.29 ohms maximum. Series A was ± 3.81 ohms. Offset correction is 10.2mohms/bit. User gain correction is now 0.00152588%/LSB for a maximum of $\pm 0.193787\%$.
- Multiple BTRs may occur before configuration of the module.

Appendix F

Differences between Series A and Series B

- When displaying copper (10mohm/bit resolution) in ohms, the resistance will be provided up to 327.67 ohms at which point an overrange will occur (overrange on the Series A was 20.72 ohms). Platinum (30mohm/bit resolution) will over range at 600.00 ohms but continue to measure until the input saturates (Series A was 399.99 ohms). Underrange for the Series B will be 1 ohm but continue to display until the input can no longer track. The Series A underranged at copper – 1.17 ohms; platinum – 18.39 ohms. The Series B continues to track beyond the under or overrange, except overrange on copper which clamps at 327.67 ohms. The Series A clamped the reading at the under or overrange value.
- Open RTD detection (excitation signal disconnected) will flag an Overrange instead of Underrange.
- Open RTD detection is < 0.5 seconds.
- Overrange will continue to function as a flag, even if single channel ohms has been requested.
- When a channel is displaying temperature and an overrange is detected, BTR temperature data for that channel will be clamped at the RTD maximum temperature (Platinum – 870°C or 598°F with Overflow, if customer bias has not been applied; Copper – 260°C or 500°F).
- A block transfer with a word length of 00 will return with the Series A block transfer default length (14 for a write; 8 for a read). To access the auto-calibration word, the block transfer length must be set to 15 for a write and 9 for a read.
- Auto-calibration can be performed on all channels simultaneously or on selected channels. In either case, channels being calibrated must be connected to the precision calibration resistors.
- The Series B module requires approximately 2 seconds to power up.
- The red LED is illuminated and the green LED is extinguished if the watchdog timer times out.
- This module employs a digital filter with 120dB/decade rolloff from a corner frequency of 8 Hz.
- This Series B module is NOT compatible with the 1771-EX extender board. Use the 1771-EZ extender board with Series B.
- Platinum RTD tables are based on IEC751 $\alpha = .00385$. The 1771-IR/A was based on MINCO Products, Inc measurements of IEC751 RTDs.

- If the module is programmed for $RTS = 0$ and the PLC is switched from run to program and back to run, an RTS timeout is inhibited on the change from program to run.
- In ohms mode, bias is able to produce a negative result.
- The excitation current on Series B flows **out** of termination A. The excitation current on the series A flowed into termination A. Systems wired according to the IR User's Manual will work without modification, presuming the transducer is polarity insensitive.
- Allowable ambient temperature change to maintain accuracy is $1^{\circ}\text{C}/\text{min}$.

A

Accuracy, [2-3](#)
auto-calibration
 gain, [7-3](#)
 offset, [7-2](#)
 performing, [7-2](#)
 saving calibration values, [7-5](#)

B

Bblock transfer read, BTR word
 assignments, [6-1](#)
block transfer programming, [4-1](#)
block transfer read, [6-1](#)
 bit/word assignments, [6-2](#)
block transfer write, configuration block,
 [5-4](#)
BTR word 9, [7-3](#)
BTW word 15, [7-3](#)

C

cable length, maximum, [3-4](#)
calibration
 auto-calibration, [7-1](#)
 tools, [7-1](#)
 types of, [7-1](#)
 words, [7-6](#)
communication, with programmable
 controllers, [2-2](#)
Compatibility, use of data table, [1-3](#)
configuration, features, [5-1](#)
Configuring your module, default for
 1771-IR, [5-6](#)
configuring your module, [5-1](#)
 bit/word descriptions, [5-5](#)
 word descriptions, [5-4](#)
contents, what your package contains, [2-3](#)

D

data format, [5-2](#)
data formats
 2's complement binary, [C-3](#)
 4-digit binary coded decimal, [C-1](#)
 signed-magnitude binary, [C-2](#)

default configuration, [5-6](#)
 all zeroes, [4-1](#)
diagnostic indicators, [3-6](#)
diagnostics
 indicators, [8-1](#)
 reported by module, [8-1](#)
 words reported, [8-2](#)
differences, between series A and series B,
 [F-1](#)

E

electrostatic damage, [3-1](#)

F

field wiring arm, [3-3](#)
 catalog number, [3-3](#)

G

grounding, [3-5](#)

I

installation, module, [3-5](#)

K

keying bands, location, [3-2](#)
keying your module, [3-2](#)

M

manual calibration
 gain, [7-7](#)
 offset, [7-6](#)
 performing, [7-5](#)
module description, [2-1](#)
module location, [3-2](#)

O

overrange and underrange values, [6-3](#)

P

Power requirements, [3-2](#)
pre-installation considerations, [3-1](#)
programming
 using 6200 software, [5-1](#)
 with multiple GETs, [D-1](#)
programming example
 PLC-2, [4-2](#)
 PLC-3, [4-4](#)
 PLC-5, [4-6](#)
programs, sample
 PLC-2, [B-1](#)
 PLC-3, [B-3](#)
 PLC-5, [B-4](#)

R

real time sampling, [5-3](#)
 bit settings, [5-3](#)
resistance, cable impedance, [3-4](#)
RTD input module, features, [2-1](#)

S

scan time, [4-7](#)
sensors
 about 2 and 4-wire, [E-1](#)
 connecting 4-wire, [E-2](#)
specifications, [A-1](#)
 error summary, [A-2](#)

T

troubleshooting, table, [8-2](#)
types of RTDs, [5-2](#)

U

units of measure, [5-2](#)

W

Wiring connections, 3-wire cable, [3-3](#)
wiring connections, [3-3](#)



ALLEN-BRADLEY
A ROCKWELL INTERNATIONAL COMPANY

As a subsidiary of Rockwell International, one of the world's largest technology companies — Allen-Bradley meets today's challenges of industrial automation with over 85 years of practical plant-floor experience. More than 13,000 employees throughout the world design, manufacture and apply a wide range of control and automation products and supporting services to help our customers continuously improve quality, productivity and time to market. These products and services not only control individual machines but integrate the manufacturing process, while providing access to vital plant floor data that can be used to support decision-making throughout the enterprise.

With offices in major cities worldwide

**WORLD
HEADQUARTERS**

Allen-Bradley
1201 South Second Street
Milwaukee, WI 53204 USA
Tel: (414) 382-2000
Telex: 43 11 016
FAX: (414) 382-4444

**EUROPE/MIDDLE
EAST/AFRICA
HEADQUARTERS**

Allen-Bradley Europa B.V.
Amsterdamseweg 15
1422 AC Uithoorn
The Netherlands
Tel: (31) 2975/60611
Telex: (844) 18042
FAX: (31) 2975/60222

**ASIA/PACIFIC
HEADQUARTERS**

Allen-Bradley (Hong Kong)
Limited
Room 1006, Block B, Sea
View Estate
28 Watson Road
Hong Kong
Tel: (852) 887-4788
Telex: (780) 64347
FAX: (852) 510-9436

**CANADA
HEADQUARTERS**

Allen-Bradley Canada
Limited
135 Dundas Street
Cambridge, Ontario N1R
5X1
Canada
Tel: (519) 623-1810
FAX: (519) 623-8930

**LATIN AMERICA
HEADQUARTERS**

Allen-Bradley
1201 South Second Street
Milwaukee, WI 53204 USA
Tel: (414) 382-2000
Telex: 43 11 016
FAX: (414) 382-2400