



CENTERLINE[®] Motor Control Centers

Installing an Early Break External Auxiliary Contact Kit

Bulletin 1494F Enclosed NEMA Disconnect Switch Rated 30A, 60A, and 100A

Catalog Number 2100H-N27 or 1495-N33

Instructions

Application

This publication explains how to install an early break external auxiliary contact kit in a Bulletin 1494F enclosed NEMA disconnect switch rated 30A, 60A and 100A.



ATTENTION: De-energize all power sources before performing this installation. Failure to de-energize all power sources can result in severe injury or death.

Recommended Tools

Screwdriver, 5/16" socket wrench, and torque wrench.

Installation

Use the following instructions to install an early break external auxiliary contact kit in a Bulletin 1494F enclosed NEMA disconnect switch rated 30A, 60A and 100A:

1. Make sure that disconnect is in the **OFF** position.
2. Refer to Figure 1 for correct assembly of auxiliary kit.
3. Remove the top right #10-32 screw which holds the disconnect mounting plate to the enclosure.
4. Position the auxiliary kit so the hole in the auxiliary mounting bracket lines up with the hole in the disconnect mounting plate. Position the tab on the auxiliary mounting bracket in the slot formed by the disconnect mounting plate and the disconnect operating mechanism.
5. Attach the auxiliary kit using the #10-32 screw that was removed in Step 2. Torque to 32 lb-in (3.6 N-m N-m).
6. Check to make sure that when the handle is in the **ON** position the disconnect operating mechanism tab engages the operating arm of the auxiliary contact.
7. Check continuity to ensure proper operation of auxiliary contacts.

Figure 1 Assembly of Auxiliary Kit

EXISTING
TOP RIGHT
#10-32 SCREW

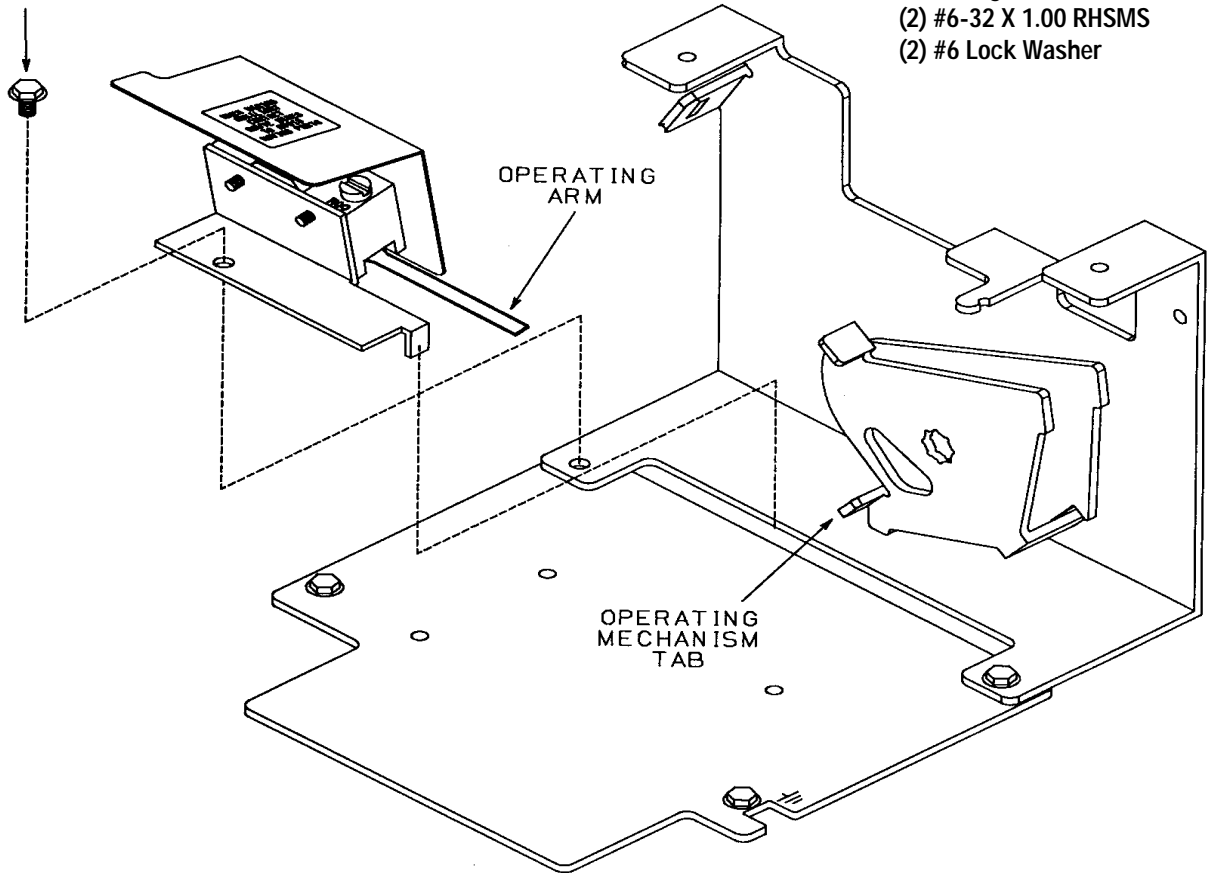

Parts List

- (1) Mounting Plate
- (1) Auxiliary Switch
- (1) Label NO Contact
- (1) Label NC Contact
- (1) Guard
- (1) Wiring Label
- (2) #6-32 X 1.00 RHSMS
- (2) #6 Lock Washer

Reach us now at www.rockwellautomation.com

Wherever you need us, Rockwell Automation brings together leading brands in industrial automation including Allen-Bradley controls, Reliance Electric power transmission products, Dodge mechanical power transmission components, and Rockwell Software. Rockwell Automation's unique, flexible approach to helping customers achieve a competitive advantage is supported by thousands of authorized partners, distributors and system integrators around the world.



Americas Headquarters, 1201 South Second Street, Milwaukee, WI 53204, USA, Tel: (1) 414 382-2000, Fax: (1) 414 382-4444
European Headquarters SA/NV, avenue Herrmann Debroux, 46, 1160 Brussels, Belgium, Tel: (32) 2 663 06 00, Fax: (32) 2 663 06 40
Asia Pacific Headquarters, 27/F Citicorp Centre, 18 Whitfield Road, Causeway Bay, Hong Kong, Tel: (852) 2887 4788, Fax: (852) 2508 1846

**Rockwell
Automation**