



# CENTERLINE<sup>®</sup> Motor Control Centers

## Installing a Terminal Board in a Bulletin 2100 Vertical Section

Catalog Number 2100-CA

### Instructions

#### Application

Use these instructions to install top-mounted or bottom-mounted, Type “C” terminal board units in Bulletin 2100 motor control center sections.

2100-5.12, Installing Units With Vertical Operating Handles, - included in kit.



**ATTENTION:** De-energize all power sources before performing this installation. Failure to de-energize all power sources can result in severe injury or death.

---

#### Recommended Tools

Screwdrivers - regular, socket with extension, torque wrench

**Note:** All screws in this kit are thread-foaming, so holes do not need to be tapped.

#### Installing the Terminal Board Top Mounted

Top-mounted: Refer to Figures 1 and 2, page 2, to assemble parts.

1. Remove the top horizontal wireway cover. Note the assembly of the two horizontal wireway baffle parts. Remove the screw, and lift out the left, then right halves of the horizontal wireway baffle. Save these parts.
2. Remove the push rivet on the right side of the horizontal wireway pan. Push up sharply on the right side of the pan and rotate it forward to release the back left part of the pan from the notch in the structure. Push the left front part of the pan slightly to the rear, and release it from the front structure notch. This pan **will not** be used with the terminal board unit.
3. Install the unit support pan. Refer to **Unit Support Pan Installation**, in Publication 2100-5.12, Installing Units With Vertical Operating Handles
4. Place the terminal board in the unit space. Line up the left slots with the 1/4-20 holes in the C-channel, and the right flange holes with the #10-32 holes in the vertical wireway wall, as shown in **Figure 2**. Secure with the appropriate screws and torque as indicated.

5. Install the sealing angle, as shown in **Figure 2**. Line up the left and right sealing angle holes with the topmost holes in the formed edge of the sideplate (left) and vertical wireway wall (right). Secure with screws and torque as indicated. Re-install the two halves of the wireway baffle. Replace the top horizontal wireway cover.
6. Install the unit door. Refer to **Door Installation** section, in Publication 2100-5.12, Installing Units With Vertical Operating Handles.

**Figure 1** Horizontal wireway baffle and pan

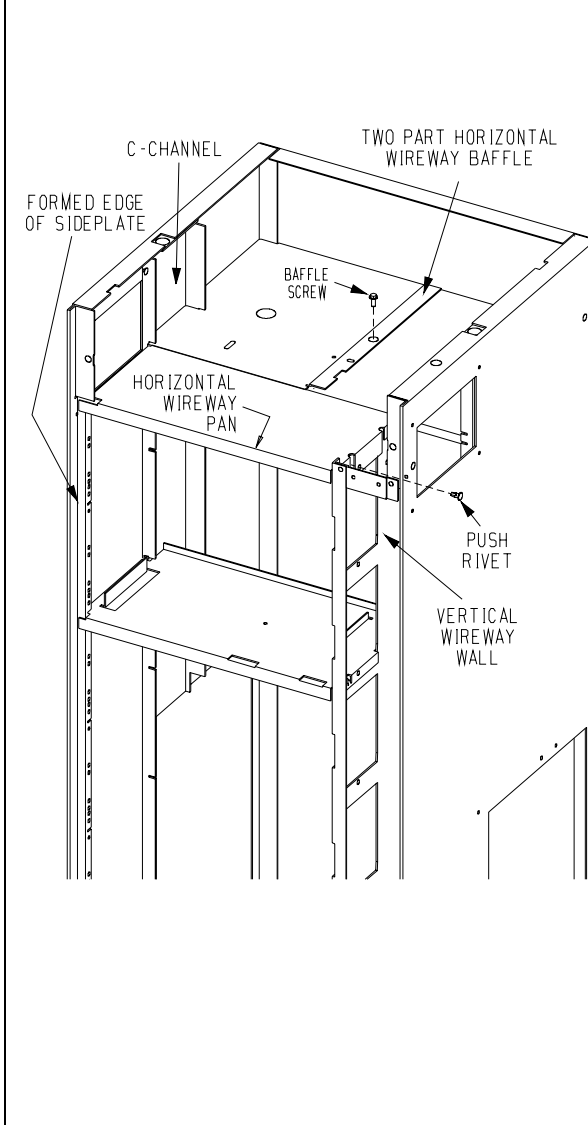

**Figure 2** Installing the sealing angle and terminal board for top-mounted units

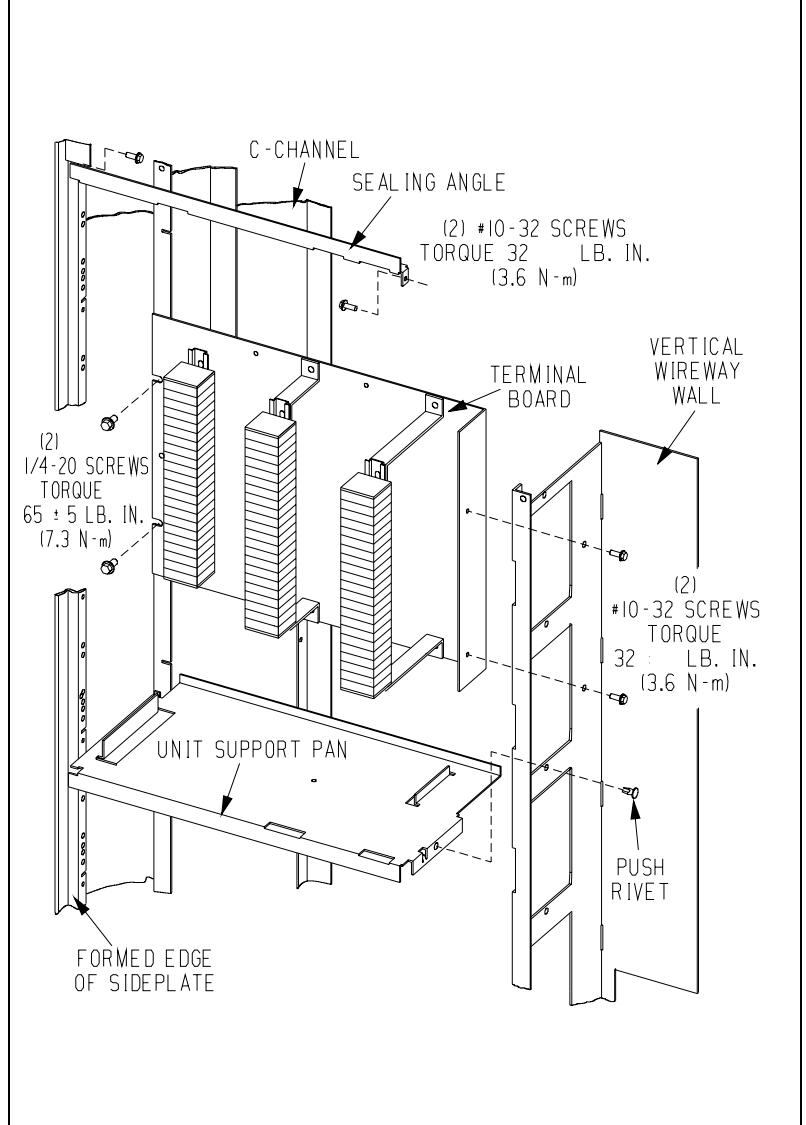

## Installing the Terminal Board Bottom Mounted

Bottom-mounted: Refer to Figures 3 and 4 to assemble parts.

1. Remove the bottom horizontal wireway cover. Remove the bottom unit support pan. Refer to the procedure in step 2 for top-mounted terminal boards.
2. Refer to step 5 for top-mounted terminal boards, to install the terminal board, using **Figure 4** as a reference.
3. Install the sealing angle, as shown in **Figure 4**. Line up the left and right sealing angle holes with the bottom-most holes in the formed edge of the sideplate (left) and vertical wireway wall (right). Secure with screws, and torque as indicated. Replace the horizontal wireway cover.
4. Install the unit support pan above the terminal board. Refer to **Unit Support Pan Installation**, in Publication 2100-5.12, Installing Units With Vertical Operating Handles.
5. Install the unit door. Refer to **Door Installation** section, in Publication 2100-5.12, Installing Units With Vertical Operating Handles.

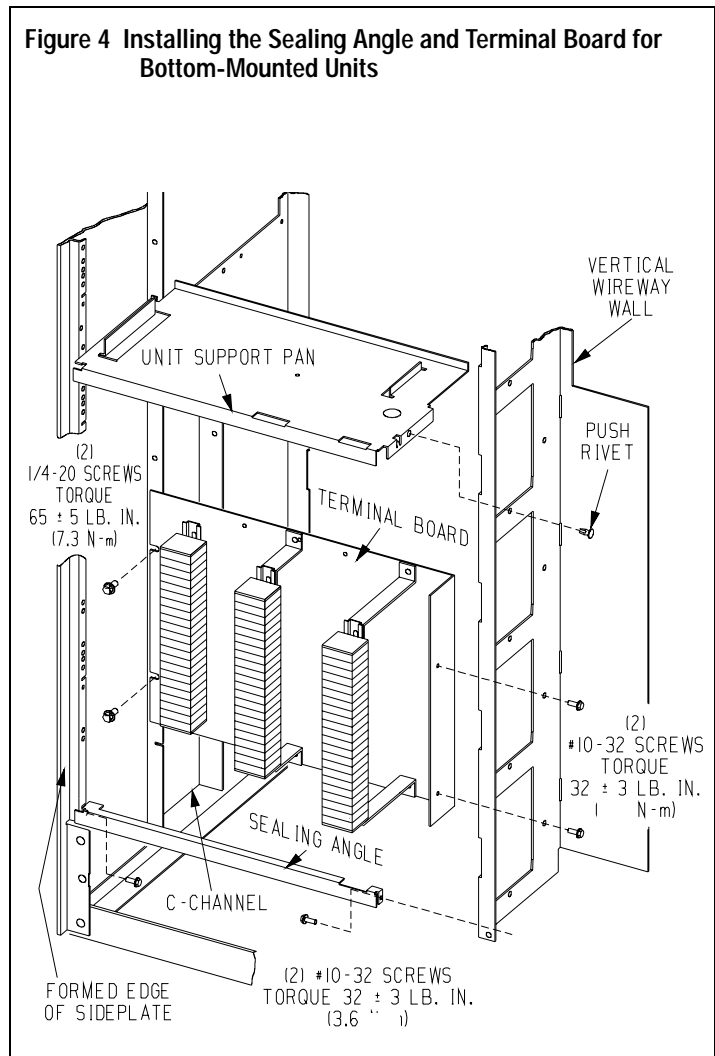
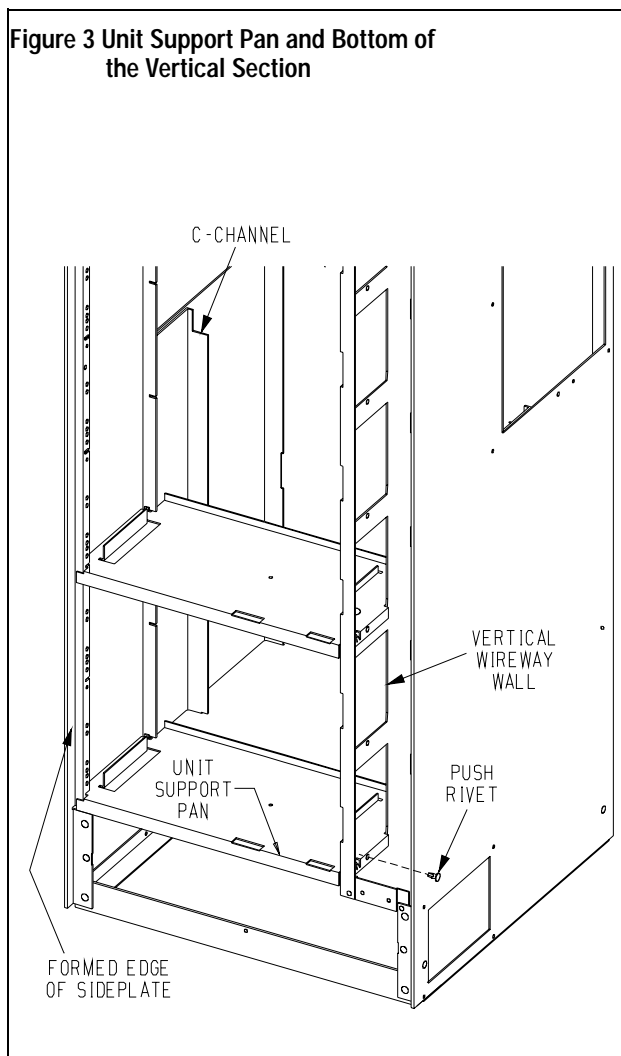

---

**Reach us now at [www.rockwellautomation.com](http://www.rockwellautomation.com)**

Wherever you need us, Rockwell Automation brings together leading brands in industrial automation including Allen-Bradley controls, Reliance Electric power transmission products, Dodge mechanical power transmission components, and Rockwell Software. Rockwell Automation's unique, flexible approach to helping customers achieve a competitive advantage is supported by thousands of authorized partners, distributors and system integrators around the world.



**Americas Headquarters**, 1201 South Second Street, Milwaukee, WI 53204, USA, Tel: (1) 414 382-2000, Fax: (1) 414 382-4444

**European Headquarters SA/NV**, avenue Herrmann Debroux, 46, 1160 Brussels, Belgium, Tel: (32) 2 663 06 00, Fax: (32) 2 663 06 40

**Asia Pacific Headquarters**, 27/F Citicorp Centre, 18 Whitfield Road, Causeway Bay, Hong Kong, Tel: (852) 2887 4788, Fax: (852) 2508 1846

**Rockwell  
Automation**

Publication 2100-IN007A-US-P - September 1999

Supersedes Publication 2100-5.26 - March 1995

Copyright 1999 of Rockwell International Corporation. Printed in the U.S.A.