



CENTERLINE[®] Motor Control Centers

NEMA Type 12 Sealing Instructions

For NEMA Type 12 structures only

Procedure

1. Remove the tube of caulking (mastic) sealer from the splice kit. Cut the nozzle at the first notch (1/8" from the end).
2. Read the application directions on the tube. Apply a continuous bead of caulking, 1/8" wide, around the outside edge of the sideplate of the fixed motor control center. See Figure 1.

Figure 1 Correct Application of Caulking

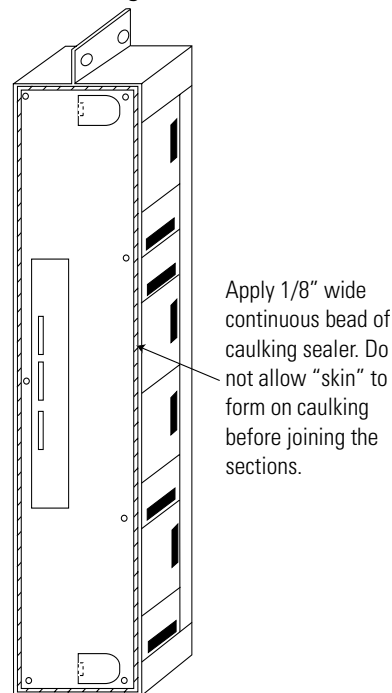

www.rockwellautomation.com

Corporate Headquarters

Rockwell Automation, 777 East Wisconsin Avenue, Suite 1400, Milwaukee, WI, 53202-5302 USA, Tel: (1) 414.212.5200, Fax: (1) 414.212.5201

Headquarters for Allen-Bradley Products, Rockwell Software Products and Global Manufacturing Solutions

Americas: Rockwell Automation, 1201 South Second Street, Milwaukee, WI 53204-2496 USA, Tel: (1) 414.382.2000, Fax: (1) 414.382.4444

Headquarters for Dodge and Reliance Electric Products

Americas: Rockwell Automation, 6040 Ponders Court, Greenville, SC 29615-4617 USA, Tel: (1) 864.297.4800, Fax: (1) 864.281.2433

Publication 2100-IN037B-EN-P - April 2003

Supersedes Publication 2100-5.25 - March 1992

© 2003 Rockwell Automation, Inc. All rights reserved. Printed in the U.S.A.