

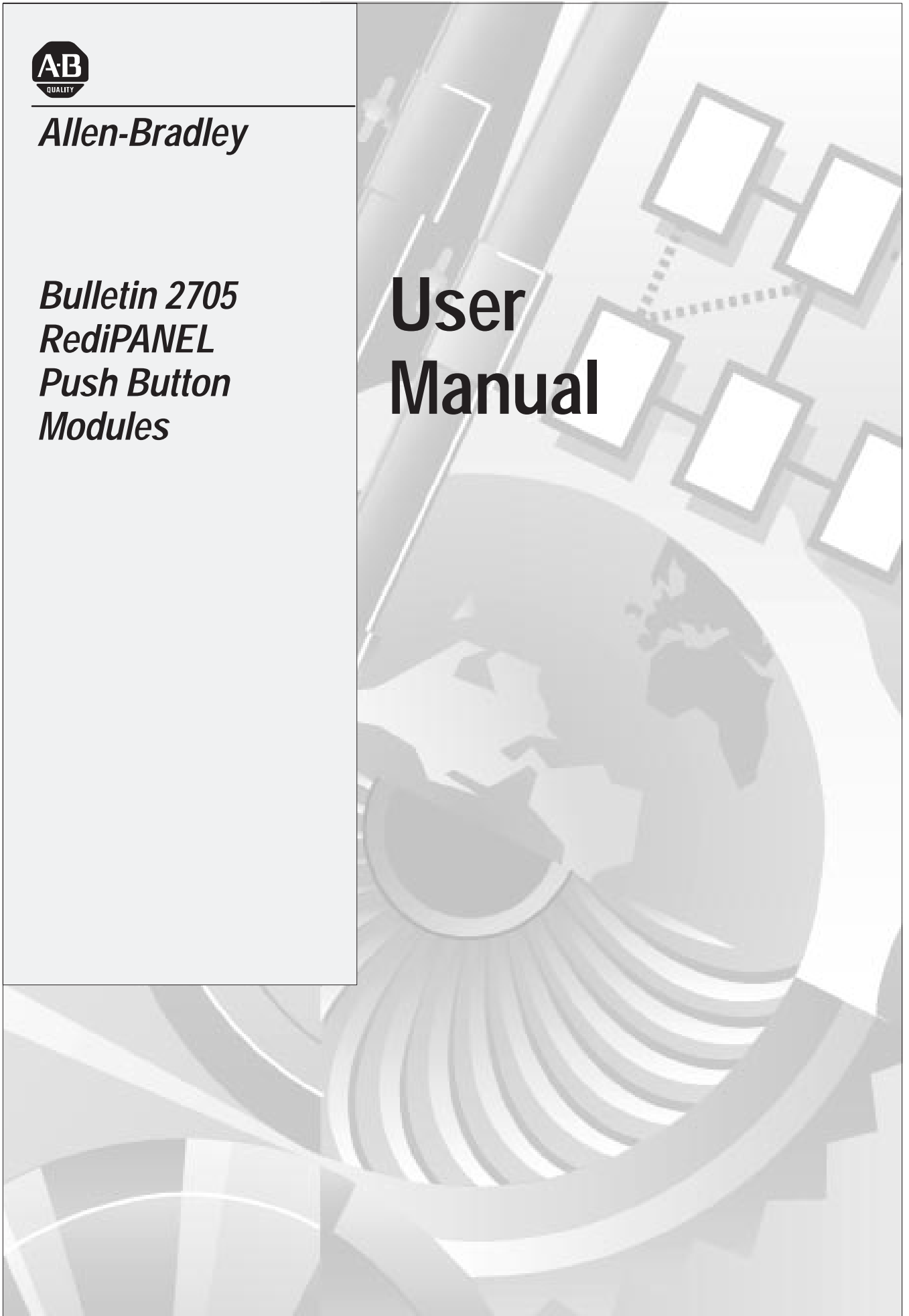

*Allen-Bradley*

*Bulletin 2705  
RediPANEL  
Push Button  
Modules*

# User Manual



## Important User Information

Solid state equipment has operational characteristics differing from those of electromechanical equipment. “Safety Guidelines for the Application, Installation and Maintenance of Solid State Controls” (Publication SGI-1.1) describes some important differences between solid state equipment and hard-wired electromechanical devices. Because of this difference, and also because of the wide variety of uses for solid state equipment, all persons responsible for applying this equipment must satisfy themselves that each intended application of this equipment is acceptable.

In no event will the Allen-Bradley Company be responsible or liable for indirect or consequential damages resulting from the use or application of this equipment.

The examples and diagrams in this manual are included solely for illustrative purposes. Because of the many variables and requirements associated with any particular installation, the Allen-Bradley Company cannot assume responsibility or liability for actual use based on the examples and diagrams.

No patent liability is assumed by Allen-Bradley Company with respect to use of information, circuits, equipment, or software described in this manual.

Reproduction of the contents of this manual, in whole or in part, without written permission of the Allen-Bradley Company is prohibited.

Throughout this manual we use notes to make you aware of safety considerations.



**ATTENTION:** Identifies information about practices or circumstances that can lead to personal injury or death, property damage, or economic loss.

---

Attentions help you:

- identify a hazard
- avoid the hazard
- recognize the consequences

**Important:** Identifies information that is especially important for successful application and understanding of the product.

## Preface

Contents of Manual .....	P-1
Intended Audience .....	P-2
Related Publications .....	P-2

## Overview

### Chapter 1

Chapter Objectives .....	1-1
Description .....	1-1
800A (16mm) Push Button Modules .....	1-2
800EP/EM (22.5mm) Push Button Modules .....	1-2
800T/H (30mm) Push Button Modules .....	1-4
NEMA Type 4X Membrane Push Button Modules .....	1-5

## Configuring the RediPANEL Module

### Chapter 2

Chapter Objectives .....	2-1
Calculating Rack Size .....	2-1
DIP Switches .....	2-3
Setting Switch Bank 1 .....	2-4
Setting Switch Bank 2 .....	2-6
Input and Output Image Tables .....	2-8

## Wiring and Installation

### Chapter 3

Chapter Objectives .....	3-1
Electrical Precautions .....	3-1
Grounding .....	3-1
Power Requirements .....	3-2
Connecting Power .....	3-2
Enclosures .....	3-3
Space and Clearance Requirements .....	3-4
Spacing of 800A Modules .....	3-4
Spacing of 800EM/EP Modules .....	3-5
Spacing of 800T/H Modules .....	3-7
Installing the 800A and Sealed Membrane Modules .....	3-8
Installing the 800EM/EP Push Button Modules .....	3-10
800EM/EP Panel Mounting .....	3-10
800EM/EP Fiberglass Enclosure Mounting .....	3-12
800EM/EP Steel Enclosure Mounting .....	3-13
Installing the 800T/H Push Button Modules .....	3-14
Connecting to a Remote I/O Link .....	3-16
Connecting to a Scanner Module .....	3-16

**Programming the RediPANEL Module**

**Chapter 4**

Chapter Objectives . . . . .	4-1
Module Bit Addresses . . . . .	4-1
Bit Addresses for 8 Button Modules . . . . .	4-1
Bit Addresses for 16 Button Modules . . . . .	4-2
Bit Addresses for 32 Button Modules . . . . .	4-5
Addressing Examples for 32 Button Modules . . . . .	4-8
Using a PLC-2 with a 1772-SD Scanner . . . . .	4-9
Using a PLC-2 with a Sub I/O Scanner . . . . .	4-11
Using a PLC-5 . . . . .	4-14
Using a PLC-5 with a Sub I/O Scanner . . . . .	4-15
Operating Cycles . . . . .	4-19
Response Time . . . . .	4-20
Handshake Mode . . . . .	4-21
PLC-5 – Flashing Lamp Example . . . . .	4-23
SLC 5/02 Programming Example . . . . .	4-24

**Maintenance and Troubleshooting**

**Chapter 5**

Chapter Objectives . . . . .	5-1
Preventive Maintenance . . . . .	5-1
Using the FAULT Indicator . . . . .	5-2
Using the COMM Indicator . . . . .	5-3
Using the Push-to-Test Button . . . . .	5-4
Removing the Back Panel of RediPANEL 800T/H Modules . . . . .	5-5
Basic Troubleshooting Questions . . . . .	5-6

**Appendix A**

**Specifications**

**Appendix B**

**Custom RediPANEL Modules**

**Appendix C**

**800A Switch Replacement Kit and LED Upgrade Kit**

**Appendix D**

**Adding/Replacing Push Button Legends**

**Appendix E**

**Replacing Lamps**

**Appendix F**

**Converting from Incandescent to LED Lamps**

**Appendix G**

**Installing/Replacing Push Buttons**

**Appendix H**

**Installing Color Inserts in Membrane Modules**

## List of Figures

Figure	Title	Page
2.1	DIP Switch Bank 1 (SW-1) Rack Address Settings for PLC-2 with 1771-SN Sub Scanner . . . . .	2–4
2.2	DIP Switch Bank 1 (SW-1) Rack Address Settings for PLC-3, PLC-5 and SLC Processors . . . . .	2–5
2.3	DIP Switch Bank 2 (SW-2) Settings . . . . .	2–6
3.1	Panel Cutout Dimensions of 800A and Sealed Modules . . . . .	3–8
3.2	Depth Dimensions of 800A and Sealed Modules . . . . .	3–9
3.3	Mounting Bracket Thumbscrews . . . . .	3–9
3.4	Panel Cutout Dimensions of 800EM/EP Push Button Modules . . . . .	3–10
3.5	Depth Dimensions of 800EM/EP Push Button Modules . . . . .	3–11
3.6	Fiberglass Enclosure Mounting Dimensions of 800EM/EP Push Button Modules . . . . .	3–12
3.7	Steel Enclosure Mounting Dimensions of 800EM/EP Push Button Modules . . . . .	3–13
3.8	Mounting Dimensions of 32 Button 800T/H Modules . . . . .	3–14
3.9	Mounting Dimensions of 16 Button 800T/H Modules . . . . .	3–15
4.1	PLC-2/20 or -2/30 Programming Example . . . . .	4–9
4.2	Block Transfer between Sub I/O Scanner and PLC-2 . . . . .	4–11
4.3	Remote I/O Addressing with a Sub I/O Scanner . . . . .	4–13
4.4	PLC-5/15 or -5/25 Programming Example . . . . .	4–14
4.5	PLC-5 Block Transfer . . . . .	4–15
4.6	PLC-5/15 and Sub I/O Scanner Programming Example . . . . .	4–17
4.7	PLC-5/15 and Sub I/O Scanner Ladder Logic Example . . . . .	4–18
4.8	Ladder Logic Handshake Rung . . . . .	4–21
4.9	Handshake Timing Diagrams . . . . .	4–22
4.10	Flashing a Button Lamp . . . . .	4–23
G.1	Replacing 800T/H Push Buttons . . . . .	G–1

## List of Tables

Table	Title	Page
1.A	NEMA Ratings for 800EP/EM Devices . . . . .	1–2
2.A	Rack Size Requirements for 8, 16 or 32 Button Modules . . . . .	2–2
2.B	DIP Switch Bank 2 (SW-2) Functions . . . . .	2–7
5.A	Testing the Contacts of Illuminated Push Buttons . . . . .	5–4
5.B	Testing the Contacts of Illuminated Selector Switches . . . . .	5–4

## Preface

This manual gives an overview of the Bulletin 2705 RediPANEL Push Button Modules and describes how to configure, install, program and troubleshoot the device on the Allen-Bradley Remote I/O network.

### Contents of Manual

This manual is organized as follows:

Chapter	Title	Description
	Preface	Describes the purpose and contents of the manual, and the intended audience.
1	Overview	Provides an overview of the Bulletin 2705 RediPANEL modules and the configurations available.
2	Configuring the RediPANEL Module	Describes how to configure RediPANEL functions using the module's DIP Switches. Configuration includes the rack address, baud rate, handshaking, flashing lamps, last state and fault mode behavior.
3	Wiring and Installation	Describes how to install the RediPANEL module and connect the module to a remote I/O link.
4	Programming the RediPANEL Module	Describes how to program the RediPANEL module from a PLC or SLC controller. Also covers handshake mode and response times.
5	Troubleshooting and Maintenance	Describes how to troubleshoot and maintain the RediPANEL module.
A	Specifications	Provides specifications for the RediPANEL modules.
B	Custom RediPANEL Modules	Describes how to create a custom unit.
C	800A Switch Replacement Kit and LED Upgrade Kit	Describes how to replace push buttons in the appropriate module. Also provides information for upgrading from incandescent to LED lamps
D	Adding/Replacing Push Button Legends	Describes how to replace push button legends in Bulletin 800A Push Button Modules.
E	Replacing Lamps	Describes how to replace lamps in Bulletin 800A Push Button Modules.
F	Converting form Incandescent Lamps to LED Lamps	Describes how to upgrade a Bulletin 800A Push Button Module from incandescent to LED lamps.
G	Installing/Replacing Push Buttons	Describes how to replace push buttons in a RediPANEL module.
H	Installing Color Inserts in Membrane Modules	Describes how to install color legend inserts in Membrane type Modules.

## Intended Audience

This manual is for the individuals responsible for installing, mounting and operating a RediPANEL Push Button Module in an industrial environment.

You must know how to program a PLC or SLC controller to operate the RediPANEL module on a Remote I/O network. You must be able to:

- create a ladder logic program in your PLC or SLC controller
- understand basic PLC or SLC ladder logic addressing
- program block transfer instructions (when using Sub I/O Scanners)

## Related Publications

Related publications you may want to refer to include:

- User manual and other support documentation for your processor and scanner.
- Allen-Bradley Publication 1770-4.1 for grounding and wiring guidelines.
- National Electrical Code published by the National Fire Protection Association of Boston, Massachusetts (refer to sections on wire sizes and types for grounding electrical equipment).

## Overview

### Chapter Objectives

This chapter describes the features, functions and operation of the Bulletin 2705 RediPANEL Push Button Modules.

Section	Page
Description	1-1
800A (16mm) Push Button Modules	1-2
800EM/EP (22.5mm) Push Button Modules	1-2
800T/H (30mm) Push Button Modules	1-4
NEMA Type 4X Membrane Push Button Modules	1-5

### Description

The Bulletin 2705 RediPANEL Push Button Modules are prepackaged push button stations that connect to Allen-Bradley programmable controllers over a Remote I/O link.

RediPANEL Push Button Modules are available with:

- Bulletin 800A (16mm) devices
- Bulletin 800EP or 800EM (22.5mm) devices
- Bulletin 800T or 800H (30mm) devices
- Sealed membrane buttons for NEMA 4X (indoor) applications

Features of the RediPANEL Push Button Modules include:

- standard and custom configurations with 8, 16, or 32 push buttons
- remote I/O operations
- built-in diagnostics
- simultaneous push button applications
- handshake mode for data input integrity
- Diagnostic Indicators



## 800A (16mm) Push Button Modules

RediPANEL 800A Modules support Bulletin 800A push buttons in 2 configurations:

- standard
- custom

The 800A modules can operate in Class 1, Division 2, Groups A, B, C, and D hazardous locations.

### Standard Configuration

Standard configurations support 8, 16 or 32 momentary illuminated 800A push buttons.

### Custom Configuration

Custom configurations support any 8, 16 or 32 of the following 800A devices:

- Momentary push buttons, illuminated
- Maintained push buttons, illuminated
- Flush head or extended head operators
- 2 position selector switches
- 2 position key switches

## 800EP/EM (22.5mm) Push Button Modules

RediPANEL 800EP/EM Modules support Bulletin 800EP and 800EM 22.5mm devices. Table 1.A lists NEMA ratings for 800EP/EM devices.

Table 1.A  
NEMA IEC Ratings for 800EP/EM Devices

Device	Type of Enclosure			
	Cold Rolled Steel Faceplate	Stainless Steel Faceplate	Metal Enclosure	Fiberglass Enclosure
800EP	4/12/13, IP66	4/4X/12/13, IP66	12/13, IP65	4/4X/12/13, IP66
800EM	4/12/13, IP66	4/12/13, IP66	12/13, IP65	4/12/13, IP66

RediPANEL 800EP/EM modules are available in 3 configurations:

- standard
- custom
- unpopulated

### Standard Configuration

Standard configurations support 16 or 32 illuminated 800EP/EM push buttons.

## Custom Configuration

Custom configurations support any 16 or 32 of the following 800EP or 800EM devices:

- Momentary push buttons, illuminated/non-illuminated
- Maintained push buttons, illuminated/non-illuminated
- Flush head, extended head, or 40mm mushroom head operators
- Pilot lights
- 2 position selector switches, illuminated/non-illuminated
- 3 position selector switches, illuminated/non-illuminated
- Hole closing plugs

3 position devices use two RediPANEL inputs leaving an unused hole on the front panel (hole plug 800E-N2).

## Unpopulated Configuration

You can order an unpopulated 800EM/EP RediPANEL Module. The unpopulated configuration consists of the enclosure and electronics without the 800EM or 800EP devices. Each 800EM/EP device is ordered separately.



**ATTENTION:** Only install Allen-Bradley 800EM or 800EP devices in the RediPANEL module. Using operators from other manufacturers voids the warranty.

---

## 800T/H (30mm) Push Button Modules

RediPANEL 800T/800H Modules support Bulletin 800T and 800H 30mm 120 VAC, Class 1, Div. 2 Groups A, B, C, and D devices only. The 800T devices have a NEMA Type 12/13 rating for applications requiring protection from oil and dust. The stainless steel faceplate of 800H devices is designed for NEMA Type 4, 4X applications (hosedown or corrosive environments).

RediPANEL 800T/H modules are available in 3 configurations:

- standard
- custom
- unpopulated

### Standard Configuration

Standard configurations support 16 or 32 illuminated 800T/H push buttons.

### Custom Configuration

Custom configurations support any 16 or 32 of the following 800T or 800H devices:

- Momentary push buttons, illuminated/non-illuminated
- Push/Pull push buttons, illuminated/non-illuminated
- Flush head, extended head or mushroom head operators
- Pilot lights
- 2 position selector switches, illuminated/non-illuminated
- 3 position selector switches, illuminated/non-illuminated
- 4 position selector switches
- Hole closing plugs

3 or 4 position devices use 2 RediPANEL inputs (and 2 connector cables), leaving a physical location with an output bit only. You can either:

1. Reduce the total number of push button devices by one for each 3 or 4 position device. Use a hole plug (Catalog No. 800T-N1B) to cover the unused hole.

For example, a 16 button module that includes a 3 or 4 position device can have a maximum of 14 additional push buttons.

2. Use a pilot light adapter cable (Catalog 800T-N309) to install a 3 or 4 position pilot light instead of the hole plug.

The above example would then support an additional pilot light for a total of 16 devices.

## Unpopulated Configuration

You can order an unpopulated 800T/800H RediPANEL module. The unpopulated configuration consists of the enclosure and electronics without the 800T or 800H devices. Each 800H/T device is ordered separately.



**ATTENTION:** Only install Allen-Bradley 800T or 800H devices in the RediPANEL. Using operators from other manufacturers voids the warranty.

---

## NEMA Type 4X Membrane Push Button Modules

The NEMA Type 4X Membrane Push Button Module has a standard configuration of 4 rows of 4 buttons. Each button has an LED in the upper right corner. These LEDs perform the same function as the lamp on the standard push button modules.

The module comes with five different color inserts to legend each button location. The inserts are coated mylar stock for writing (ink, pencil, or marker), typing, or printing a legend.

## Configuring the RediPANEL Module

### Chapter Objectives

This shows how to configure the RediPANEL Module using DIP Switches.

Section	Page
Calculating Rack Size	2-1
DIP Switches	2-3
Setting Switch Bank 1	2-4
Setting Switch Bank 2	2-6
Input and Output Image Tables	2-8

### Calculating Rack Size

DIP Switches on the RediPANEL are used to set Input/Output (I/O) requirements. On a Remote I/O network, I/O is measured in terms of racks. The smallest unit is a 1/4 rack.

Rack size determines the amount of space the module uses in the Input and Output Image tables. When you select a rack size (using DIP switches), space is reserved in the Input and Output Image Tables of your processor.

Three factors determine rack size:

- Input/Output size
- Flashing functions
- Handshaking functions

#### Input/Output Size

Input/Output Size directly relates to the number of push buttons on the RediPANEL module. A 16 push button module has 16 inputs and 16 outputs. A 32 push button module has 32 inputs and 32 outputs.

#### Flashing Function

The flashing function causes the RediPANEL outputs to flash without additional PLC programming. If flashing is enabled, the processor allocates additional memory in the I/O Image Table. By branching the RediPANEL output bits with the corresponding flashing bits, the RediPANEL outputs blink at a 0.5 second rate.

A 16 push button module requires 16 additional outputs. A 32 push button module requires 32 additional outputs to enable the flashing function.

#### Handshake

The handshake function latches an input bit until it is acknowledged by the processor. Handshaking requires an additional output bit in the Output Image Table.

Table 2.A lists the rack size requirements for an 8, 16 or 32 button RediPANEL module. The rack size varies depending on the number of push buttons and the functions used.

**Table 2.A**  
**Rack Size Requirements for 8, 16, and 32 Button RediPANEL Modules**

Number of Buttons	Handshake		Lighted	Lighted and Flashing		
	No	Yes				
8	✓		1/4			
		✓				
16	✓					1/2
		✓				
32	✓		1/2	3/4		
		✓				

You can ignore the I/O requirements in the table and specify a full rack by setting switch 6 in DIP Switch Bank 2 on the RediPANEL. A full rack is automatically reserved in the Input/Output Image Tables of the processor.

## DIP Switches

The RediPANEL module has two DIP Switch banks.

Switch Bank	Function
Switch Bank 1 (SW-1)	Sets rack address.
Switch Bank 2 (SW-2)	Controls baud rate, flashing lamps, fault mode behavior, handshaking and last states.

The DIP Switch banks are located on the back of the RediPANEL module. You can access the DIP switches by opening the back panel, as shown below.

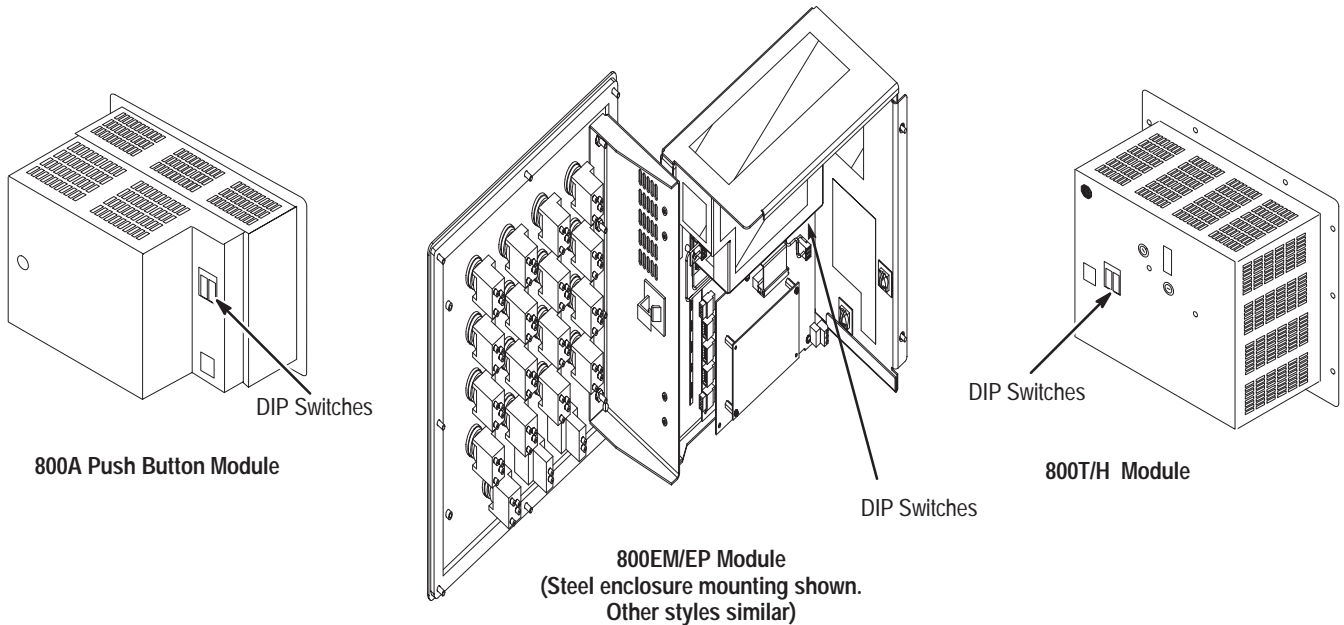

The following figure shows ON/OFF positions of the rocker style switches.

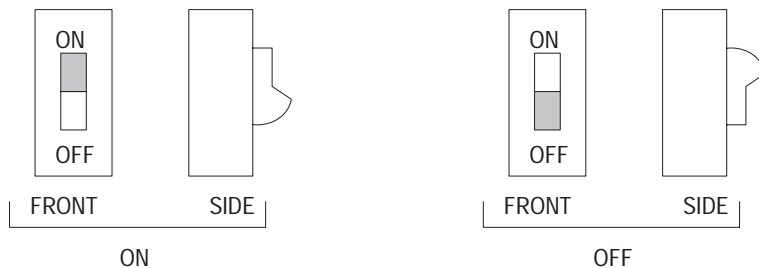

ON and OFF switch settings are indicated by shading.



**ATTENTION:** Remove power from the module before setting switches. Switch settings are scanned only on power-up. The new settings take effect when you power-up the module.

## Setting Switch Bank 1

Switch Bank 1 (SW-1) sets the rack address.

Figure 2.1 shows rack address settings for the PLC-2 or any PLC using a 1771-SN Sub Scanner.

**Figure 2.1**  
**DIP Switch Bank 1**  
Rack Address Settings for PLC-2 or PLC with 1771-SN Sub Scanner

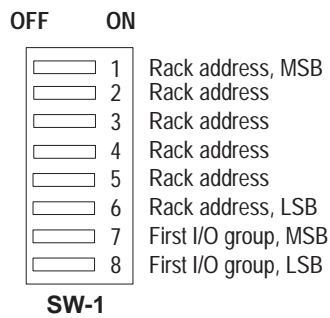

I/O Rack Address	Switch Settings – Series B					
	1	2	3	4	5	6
1	on	on	on	on	on	on
2	on	on	on	on	on	off
3	on	on	on	on	off	on
4	on	on	on	on	off	off
5	on	on	on	off	on	on
6	on	on	on	off	on	off
7	on	on	on	off	off	on

### Example

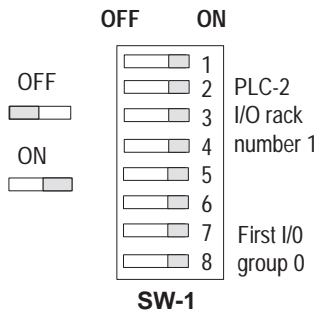

First I/O Group	Switch Settings	
	7	8
0	on	on
2	on	off
4	off	on
6	off	off

Figure 2.2 lists rack address settings for the PLC-3 and PLC-5 family.



**Figure 2.2**  
**DIP Switch Bank 1**  
**Rack Address Settings for PLC-3, PLC-5 and SLC Processors**

I/O Rack Address	Switch Settings					
	1	2	3	4	5	6
00 ①	on	on	on	on	on	on
01	on	on	on	on	on	off
02	on	on	on	on	off	on
03	on	on	on	on	off	off
04	on	on	on	off	on	on
05	on	on	on	off	on	off
06	on	on	on	off	off	on
07	on	on	on	off	off	off
10	on	on	off	on	on	on
11	on	on	off	on	on	off
12	on	on	off	on	off	on
13	on	on	off	on	off	off
14	on	on	off	off	on	on
15	on	on	off	off	on	off
16	on	on	off	off	off	on
17	on	on	off	off	off	off
20	on	off	on	on	on	on
21	on	off	on	on	on	off
22	on	off	on	on	off	on
23	on	off	on	on	off	off
24	on	off	on	off	on	on
25	on	off	on	off	on	off
26	on	off	on	off	off	on
27	on	off	on	off	off	off
30	on	off	off	on	on	on
31	on	off	off	on	on	off
32	on	off	off	on	off	on
33	on	off	off	on	off	off
34	on	off	off	off	on	on
35	on	off	off	off	on	off
36	on	off	off	off	off	on
37	on	off	off	off	off	off

I/O Rack Address	Switch Settings					
	1	2	3	4	5	6
40	off	on	on	on	on	on
41	off	on	on	on	on	off
42	off	on	on	on	off	on
43	off	on	on	on	off	off
44	off	on	on	off	on	on
45	off	on	on	off	on	off
46	off	on	on	off	off	on
47	off	on	on	off	off	off
50	off	on	off	on	on	on
51	off	on	off	on	on	off
52	off	on	off	on	off	on
53	off	on	off	on	off	off
54	off	on	off	off	on	on
55	off	on	off	off	on	off
56	off	on	off	off	off	on
57	off	on	off	off	off	off
60	off	off	on	on	on	on
61	off	off	on	on	on	off
62	off	off	on	on	off	on
63	off	off	on	on	off	off
64	off	off	on	off	on	on
65	off	off	on	off	on	off
66	off	off	on	off	off	on
67	off	off	on	off	off	off
70	off	off	off	on	on	on
71	off	off	off	on	on	off
72	off	off	off	on	off	on
73	off	off	off	on	off	off
74	off	off	off	off	on	on
75	off	off	off	off	on	off
76	off	off	off	off	off	on

① Rack 00 not valid with PLC-5s.

**Specifying First I/O Group**

First I/O Group	Switch Settings	
	7	8
0	on	on
2	on	off
4	off	on
6	off	off

## Setting Switch Bank 2

Figure 2.3 shows the functions and settings for Switch Bank 2 (SW-2). Table 2.B defines the DIP Switch functions.

**Figure 2.3**  
DIP Switch Bank 2 (SW-2) Settings

### RediPANEL 800A and 800EP/EM Membrane Modules

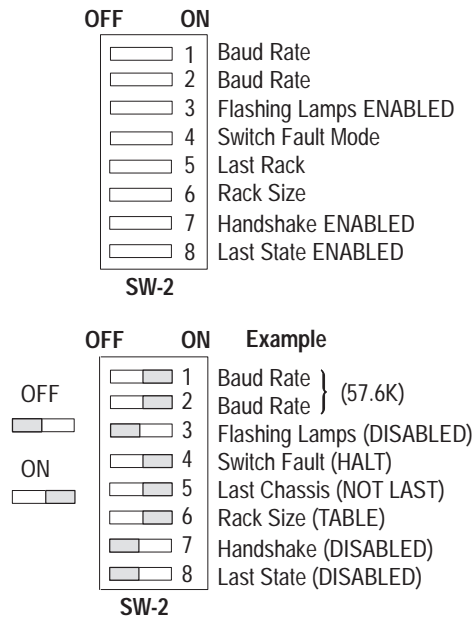

Switch	Description	Switch Setting	
1 & 2	Baud Rate	57.K 1=ON 2=ON 115.2K 1=OFF 2=ON 230.4K 1=ON 2=OFF N/A 1=OFF 2=OFF	
3	Flashing Lamps	OFF=Disabled	ON=Enabled
4	Switch Fault	OFF=Continue	ON=Halt
5	Last Chassis	OFF=Last	ON=Not Last
6	Rack Size	OFF=Full	ON=Table
7	Handshake	OFF=Disabled	ON=Enabled
8	Last State	OFF=Disabled	ON=Enabled

### RediPANEL 800T/H Modules

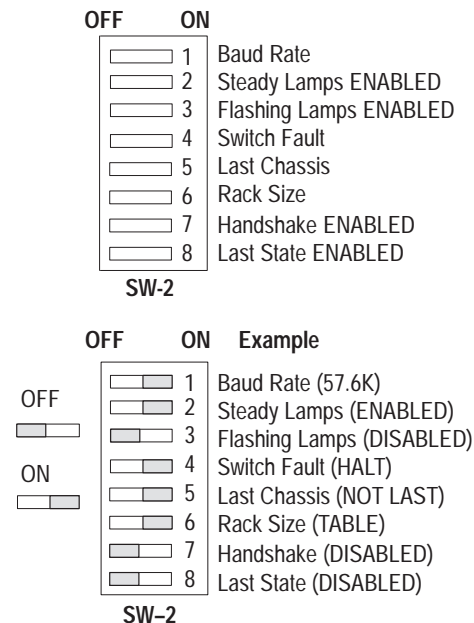

Switch	Description	Switch Setting	
		OFF	ON
1	Baud Rate	115.2K	57.6K
2	Steady Lamps	Disabled	Enabled
3	Flashing Lamps	Disabled	Enabled
4	Switch Fault	Continue	Halt
5	Last Chassis	Last	Not Last
6	Rack Size	Full	Table
7	Handshake	Disabled	Enabled
8	Last State	Disabled	Enabled

**Table 2.B**  
**DIP Switch Bank 2 (SW-2) Functions**

DIP Switch SW2		Options	Description
Number	Function		
1, 2 ①②	Baud Rate	<ul style="list-style-type: none"> <li>• 57.6K</li> <li>• 115.2K</li> <li>• 230.4K</li> </ul>	<ul style="list-style-type: none"> <li>• 57.6K for links up to 10,000 feet (3,000 meters)</li> <li>• 115.2K for links up to 5,000 feet (1,500 meters)</li> <li>• 230.4K for links up to 2,500 feet (750 meters)</li> </ul>
3	Flashing Lamps	<ul style="list-style-type: none"> <li>• Enabled</li> <li>• Disabled</li> </ul>	When enabled, the Module uses the built-in flash feature to flash the lamps inside the push button at a 0.5 sec. rate. Programming ON/OFF Timers is not necessary.
4	Switch Fault Mode	<ul style="list-style-type: none"> <li>• Halt</li> <li>• Continue</li> </ul>	<ul style="list-style-type: none"> <li>• Halt stops all push button operations when a fault is detected using the Push-to-Test button. Communications with the PLC is disabled, the COMM LED turns off, and the FAULT LED illuminates.</li> <li>• Continue forces all associated input image table bits to the released state. The rest of the push buttons continue to operate while the faulted button remains inoperable.</li> </ul>
5	Last Rack	<ul style="list-style-type: none"> <li>• Last</li> <li>• Not Last</li> </ul>	<ul style="list-style-type: none"> <li>• Last tells the controller that the RediPANEL module is the last device in that logical rack, not necessarily the last remote rack on the I/O link. The Last setting is not a terminator resistor for the remote I/O link.</li> <li>• Not Last specifies that the RediPANEL module is not the last device in the logical rack.</li> </ul>
6	Rack Size	<ul style="list-style-type: none"> <li>• Full</li> <li>• Table</li> </ul>	<ul style="list-style-type: none"> <li>• Full configures the module as a full rack (regardless of the I/O requirements in Table 2.A). The Full setting is required when connecting RediPANEL modules directly to PLC-5/15 (Series B Revision G or earlier) or PLC-5/25 (Series A Revision C or earlier) controllers.</li> <li>• Table configures the rack size of the module using Table 2.A.</li> </ul>
7	Handshake	<ul style="list-style-type: none"> <li>• Enabled</li> <li>• Disabled</li> </ul>	<ul style="list-style-type: none"> <li>• When enabled, handshaking allows the use of the handshake bit. Any push button depression is held ON until the controller verifies that it has received the signal. The controller's ladder logic must contain a handshake rung or the RediPANEL module will not function properly. See page 4–21 for details on using the Handshake Mode.</li> <li>• When disabled, handshaking holds any push button depression ON for 100 milliseconds.</li> </ul>
8	Last State	<ul style="list-style-type: none"> <li>• Enabled</li> <li>• Disabled</li> </ul>	<ul style="list-style-type: none"> <li>• If Last State is enabled, when communications is lost, the module stops sending signals and the COMM LED turns off. Any output signals that were on when communication was lost return to that state when communications is regained. The module locks up and ignores any push button depressions. Lamps remain in their last state.</li> <li>• If Last State is disabled, the module turns off any lamps that were on when communications is lost. When communications is regained, the module updates itself and resumes operations.</li> </ul>

① Switches 1 and 2 set the baud rate on RediPANEL 800A, 800EM/EP, and Membrane modules. Switch 1 only sets the baud rate on RediPANEL 800T/H modules.

② Switch 2 sets steady lamps for the 800T/H RediPANEL.



### I/O Image Tables for 16 Push Button Modules

#### 16 Push Button Module, 1/4 and 1/2 Rack

Output Image Table  
1/4 Rack (Lamps Enabled)

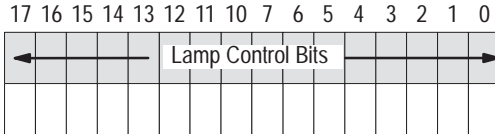

Input Image Table  
1/4 Rack

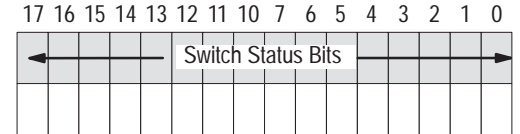

WORD 0  
WORD 1

Output Image Table  
1/4 Rack (Lamps & Flash Enabled)

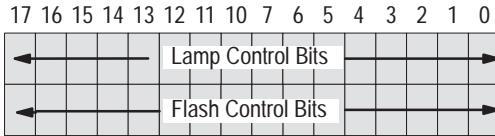

Input Image Table  
1/4 Rack

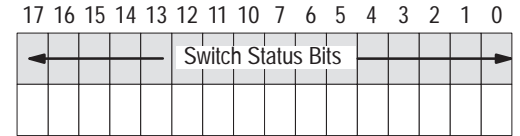

WORD 0  
WORD 1

Output Image Table  
1/4 Rack (Handshaking & Lamps Enabled)

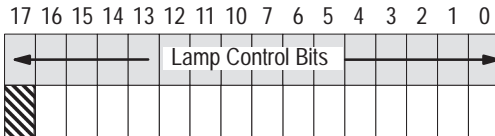

Input Image Table  
1/4 Rack

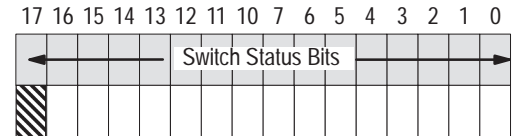

WORD 0  
WORD 1

Output Image Table  
1/2 Rack (Handshaking, Lamps & Flash Enabled)

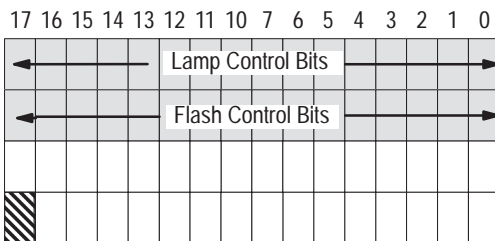

Input Image Table  
1/4 Rack (Handshaking Enabled)

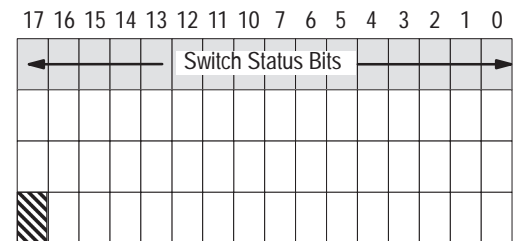

WORD 0  
WORD 1  
WORD 2  
WORD 3

 Handshake Bit

**16 Push Button Module, Full Rack**

Output Image Table  
Full Rack (Lamps, Flash and Handshaking Enabled)

17	16	15	14	13	12	11	10	7	6	5	4	3	2	1	0	
← Lamp Control Bits →																
← Flash Control Bits →																

Input Image Table  
Full Rack (Handshaking Enabled)

17	16	15	14	13	12	11	10	7	6	5	4	3	2	1	0	
← Switch Status Bits →																

Output Image Table  
Full Rack (Lamps Enabled)

17	16	15	14	13	12	11	10	7	6	5	4	3	2	1	0	
← Lamp Control Bits →																

Input Image Table  
Full Rack

17	16	15	14	13	12	11	10	7	6	5	4	3	2	1	0	
← Switch Status Bits →																

 Handshake Bit

**Note:** In 800T/H Push Button Modules, the cables that connect to the push buttons are marked A00- A17. This corresponds to input and output bit locations 00-17.

### I/O Image Tables for 32 Push Button Modules

Output Image Table  
1/2 Rack (Handshaking and Lamps Enabled, Flash Disabled)

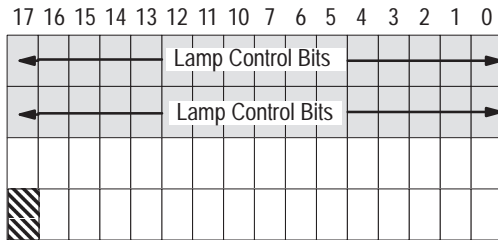

Input Image Table  
1/2 Rack (Handshaking Enabled)

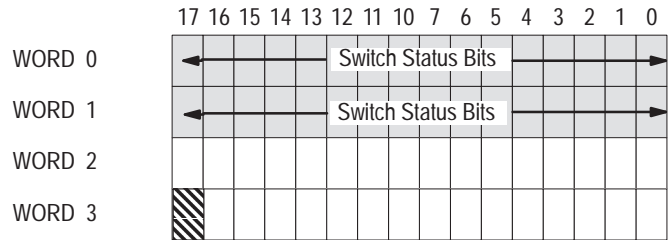

Output Image Table  
3/4 Rack (Lamps, Flash and Handshaking Enabled)

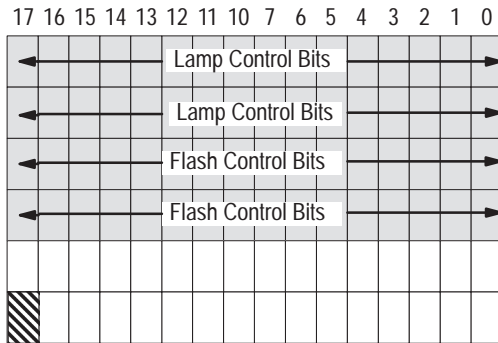

Input Image Table  
3/4 Rack (Handshaking Enabled)

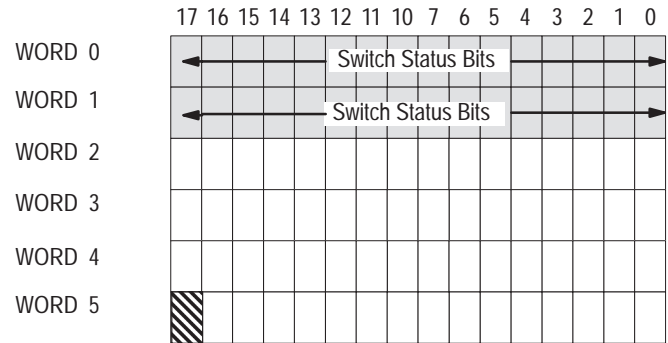

Output Image Table  
Full Rack (Regardless of Configuration)

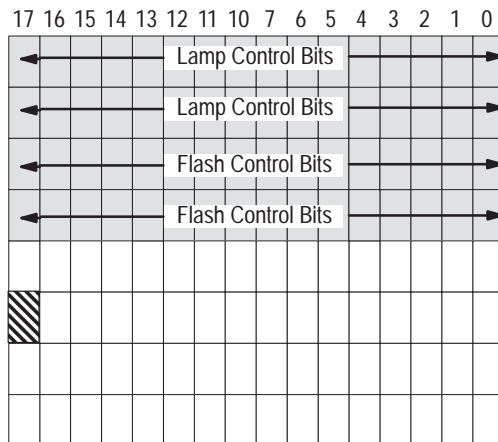

Input Image Table  
Full Rack (Regardless of Configuration)

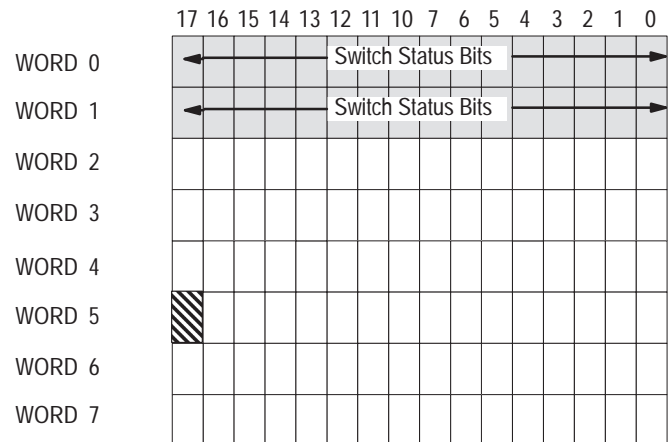

 Handshake Bit

**Note:** In 800T/H Push Button Modules, the cables that connect to the push buttons are marked A00- A17. This corresponds to input and output bit locations 00-17.

## Wiring and Installation

### Chapter Objectives

This chapter contains the following sections.

Section	Page
Electrical Precautions	3-1
Grounding	3-1
Power Requirements	3-2
Connecting Power	3-2
Enclosures	3-3
Space and Clearance Requirements	3-4
Installing the 800A and Sealed Membrane Modules	3-8
Installing the 800EM/EP Modules	3-10
Installing the 800T/H Push Button Modules	3-14
Connecting to a Remote I/O Link	3-16
Connecting to a Scanner Module	3-16

### Electrical Precautions

Install the Bulletin 2705 Push Button Module using publication NFPA 70E, Electrical Safety Requirements for Employee Workplaces.



**ATTENTION:** Do not program any of the devices on the Push Button Module as emergency stop switches. Emergency stop switches must be hardwired to the master control relay of the system to turn off all machine power completely.

Additional guidelines to follow include:

- Careful wire routing helps cut down on electrical noise. Route incoming power to the module by a separate path from the communication cables. **Do not run communications wiring and power wiring in the same conduit!**
- Where wire paths must cross, make their intersection perpendicular.
- Grounding helps to limit the effects of noise due to electromagnetic interference (EMI). To avoid EMI, use shielded cables.

### Grounding

Grounding is an important safety measure in electrical installations. As mentioned previously, with solid state systems grounding helps to limit the effect of noise from EMI (electromagnetic interference).

An authoritative source on grounding requirements is the *National Electrical Code* published by the National Fire Protection Association of Boston, Massachusetts. Refer to an article of the *Code* that discusses the types and sizes of wire conductors and safe methods of grounding electrical equipment and components.



## Power Requirements

RediPANEL Modules operate with different power sources.

Module Type	Power Source
800A	90 to 264V AC, 47 - 63 Hz 18 to 30V DC
Sealed Membrane	90 to 264V AC, 47 - 63 Hz 18 to 30V DC
800T/H	120 or 240V AC, 47 - 63 Hz
800EM/EP	90 to 264V AC, 47 - 63 Hz 18 to 30V DC

The AC power supplies for the 800A and Membrane Modules have an automatic over voltage shutdown. Automatic shutdown occurs if the output voltage of the 5V supply rises by 25% or the 12V supply rises by 20%. To reset the RediPANEL after an automatic shutdown, disconnect AC power as follows:

For :	Disconnect a AC power for:
120V AC Source	minimum of 30 seconds
240V AC Source	minimum of 60 seconds

## Connecting Power

Connect power lines to the module as shown below:

Terminal Block	Connection
GND	Ground Wire
L2/N	Neutral Wire
L1	Power Wire
(-)	DC 0 Volts
(+)	DC +24 Volts



**ATTENTION:** Do not apply power to the module until all electrical connections, including communications lines, have been connected.



**ATTENTION:** The ground terminal (GND) must be connected to a reliable low impedance earth ground to protect the display against electrical noise. The ground will also help protect personnel from electrical shock if a voltage is shorted to the enclosure.

1. Connect ground wire to the GND terminal on the terminal block.
2. Connect the power lines, L1 and L2/N , or (-) and (+DC). Do not apply power until all connections have been made.
3. Connect the communications lines as described on page 3-16.
4. Apply power and verify power up operation.

## Enclosures

You must use an enclosure to protect the electronics of the Push Button Module from atmospheric contamination. Standards established by the National Electrical Manufacturer's Association (NEMA) define enclosure types based on the degree of protection an enclosure will provide.

### Heat Dissipation

Within the enclosure, the Push Button Module (or Modules) requires room for convection cooling.

In some applications, other equipment inside (or outside) the enclosure may produce too much heat. Place blower fans inside the enclosure to circulate air to reduce hot spots near components. In extreme cases, use air conditioning to prevent heat build-up.



**ATTENTION:** Do not use unfiltered outside air. It could contain contaminants or dirt harmful to the components.

---

## Space and Clearance Requirements

### Spacing of 800A Modules

To properly space 800A Push Button Modules, follow these guidelines.

- **Vertical stacking of modules:** The lower edge of the top cutout must be at least 6 inches (152mm) from the top edge of the lower cutout. The enclosure must be at least 8 inches (203mm) deep.
- **Horizontal mounting:** Mount modules as close together as physically possible. The enclosure must be at least 8 inches (203mm) deep.

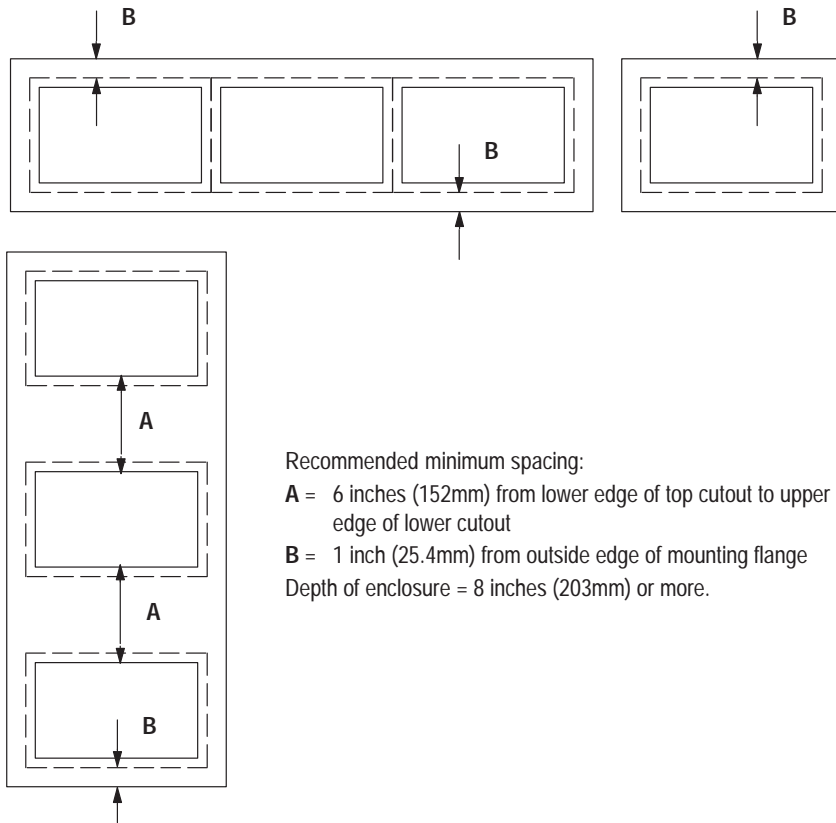

## Spacing of 800EM/EP Modules

The 800EM/EP Push Button Modules are available in 3 different mounting styles:

- Panel Mounting
- Fiberglass Enclosure Mounting
- Steel Enclosure Mounting

### Panel Mounting Spacing Requirements

- **Vertical stacking of modules:** The lower edge of the top cutout must be at least 6 inches (152mm) from the top edge of the lower cutout. The enclosure must be at least 8 inches (203mm) deep.
- **Horizontal mounting:** Mount modules as close together as physically possible. The enclosure must be at least 8 inches (203mm) deep.
- **Mounting Screw Torque:** Torque mounting screws to 8 lb-in (.908 N-m) to ensure good seal between module gasket and panel.

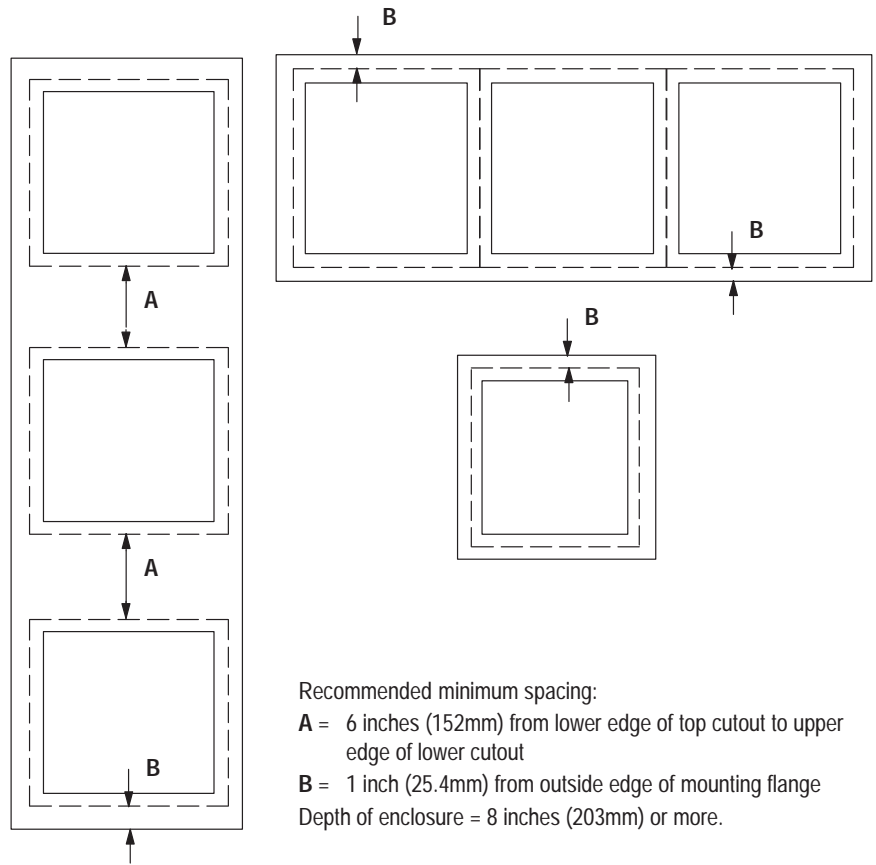

### Fiberglass Enclosure Mounting Clearance Requirements

The enclosure mounting style requires a 2 inch (50 mm) clearance on the latched side for opening and closing the enclosure cover. Adequate clearance must be provided to allow for a minimum 90° swing of the cover.

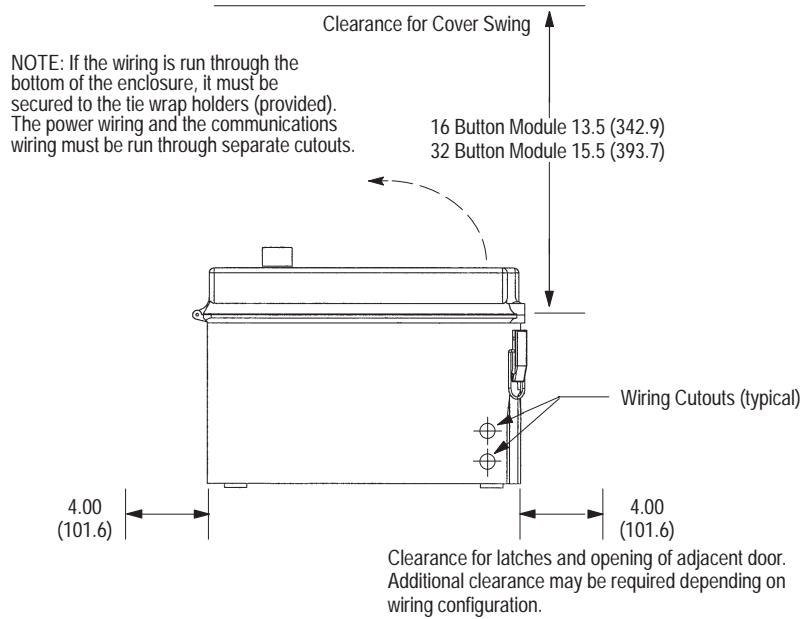

### Steel Enclosure Mounting Clearance Requirements

The mounting style requires a 3 inch (76 mm) clearance on the latched side for opening and closing the enclosure cover. Adequate clearance must be provided to allow for a minimum 90° swing of the cover.

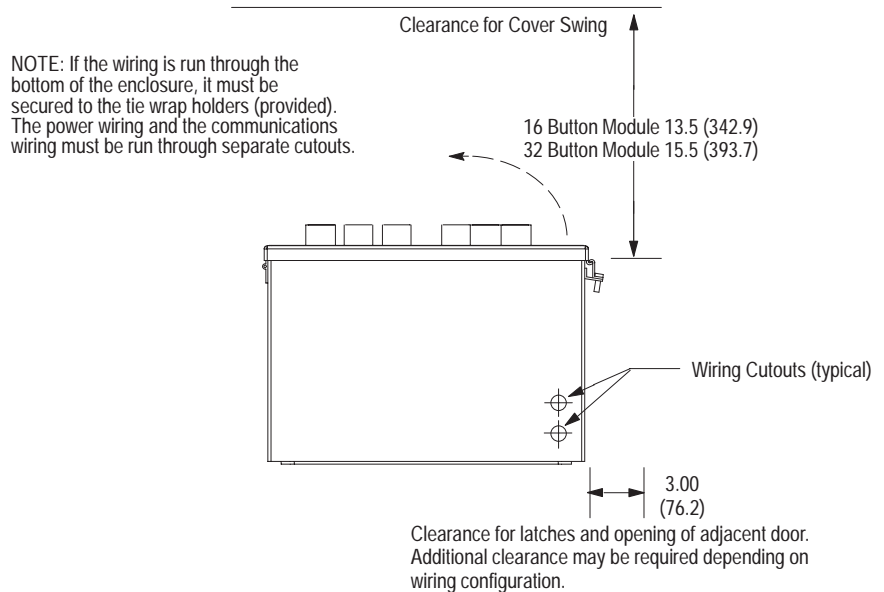

### Spacing of 800T/H Modules

You can mount 16 and 32 Push Button 800T/H RediPANEL Modules in either a vertical or horizontal orientation. To mount more than one RediPANEL Push Button Module in the same enclosure, use a 1 inch (25.4 mm) minimum horizontal/vertical spacing between modules (measured at the front panel).

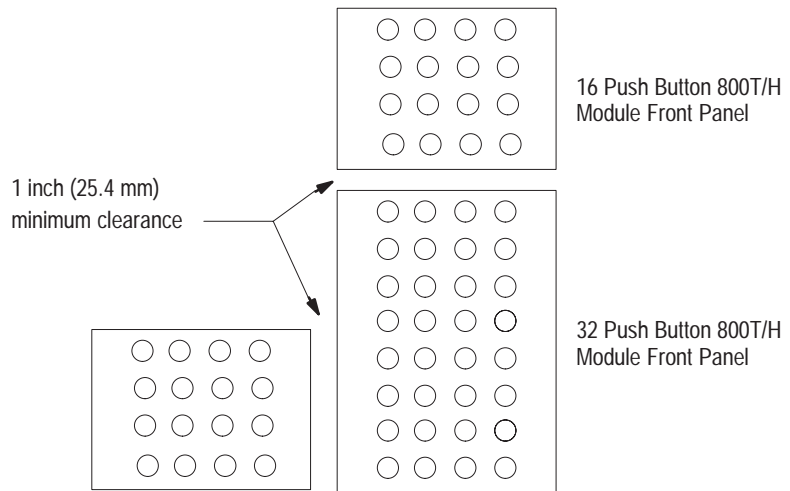

## Installing the 800A and Sealed Membrane Modules

Mounting tabs are built into the Module. After sliding the Module into the enclosure, the tabs secure the Module until the mounting brackets are in place. The installation procedure follows.

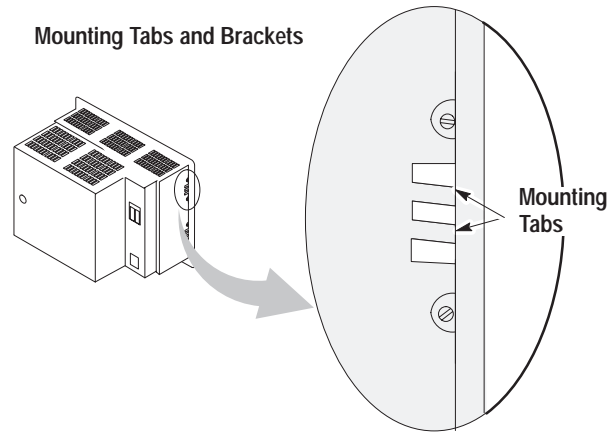

### To install the 800A and Sealed Membrane Modules:

1. Cut an opening in the panel approximately 5.86 inch (148.84mm) H x 8.61 inch (218.69mm) W. See Figure 3.1.

Figure 3.1  
Panel Cutout Dimensions in Inches (mm)  
800A and Sealed Modules

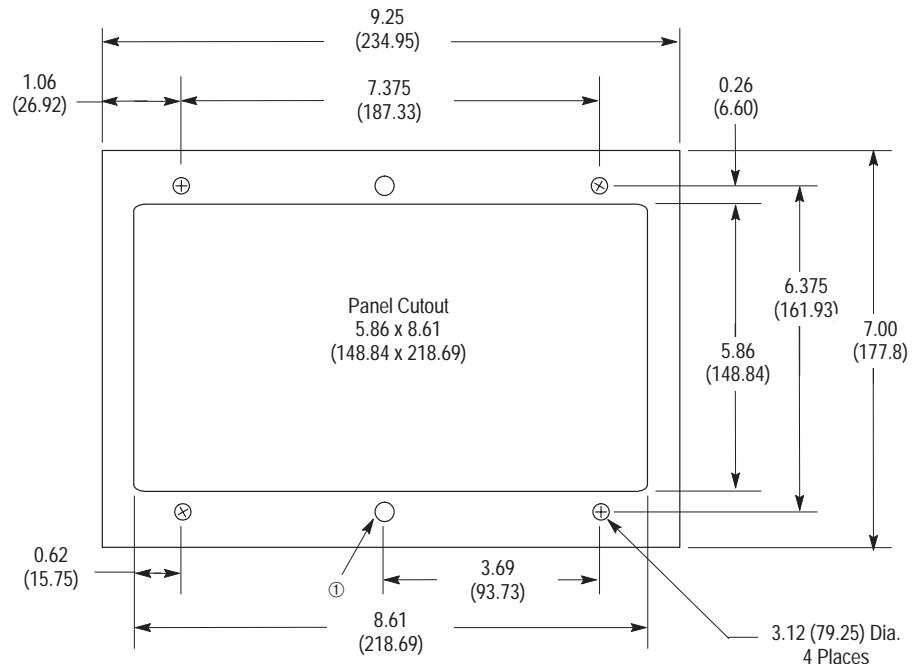

① These 2 additional 0.312 inch (7.92 mm) diameter holes are required for NEMA Type 4X push button modules.

Figure 3.2  
Depth Dimensions in Inches (mm)  
800A and Sealed Modules

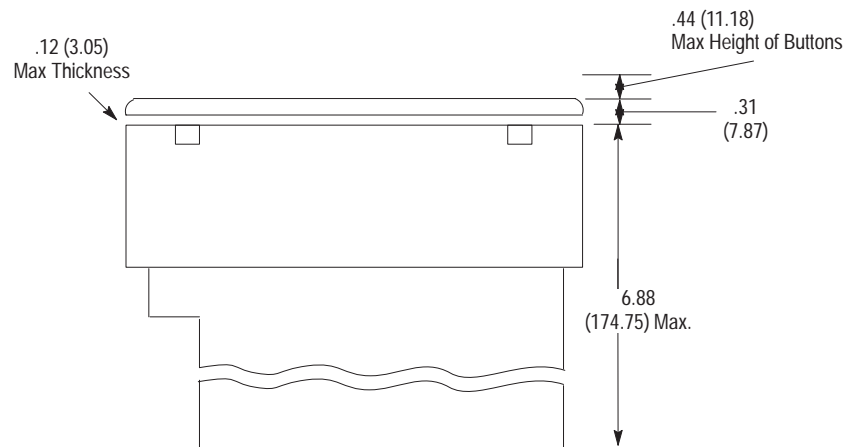

2. Drill 4 (or 6) 0.312" (7.92mm) diameter holes for the top and bottom mounting brackets.
3. Slide the Module through the opening. The mounting tabs help seat the Module against an 1/16" (1.6mm) to 1/8" (3.2mm) thick enclosure.
4. To complete the mechanical installation, apply the mounting brackets and tighten all the captive knurled thumbscrews. Figure 3.3 shows the location of these screws. NOTE: Your unit may not have a mounting bracket and thumbscrews. In that case, tighten the #10-32 nuts that are provided to complete the installation.

Figure 3.3  
Mounting Bracket Thumbscrews

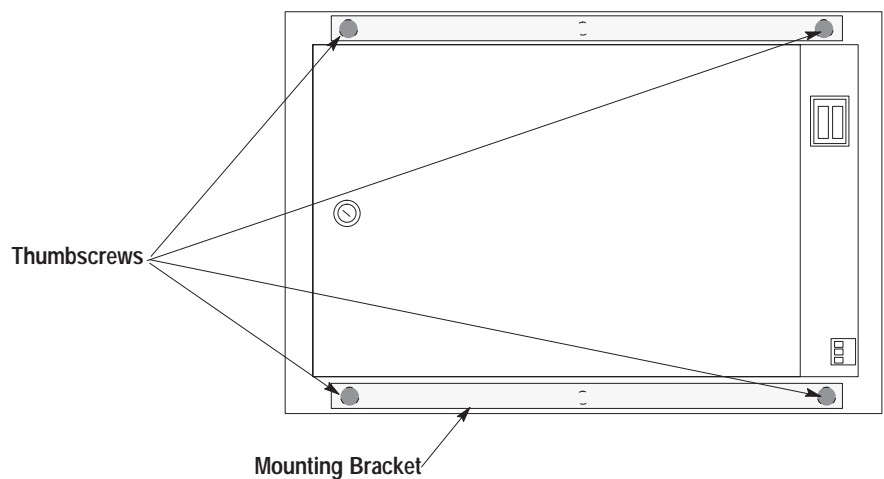



## Installing the 800EM/EP Push Button Modules

The 800EM/EP Push Button Modules are available in 3 different mounting styles:

- Panel Mounting
- Fiberglass Enclosure Mounting
- Steel Enclosure Mounting

This section shows how to install all 3 versions of the 16 and 32 Push Button 800EM/EP Modules.

### 800EM/EP Panel Mounting

**To install a 16 or 32 Push Button 800EM/EP Faceplate Module:**

1. Cut an opening in the panel approximately 12.55 inch (318.8mm) H x 12.75 inch (323.9mm) W. See Figure 3.4.

**Figure 3.4**  
Panel Cutout Dimensions in Inches (mm)  
800EM/EP Push Button Modules

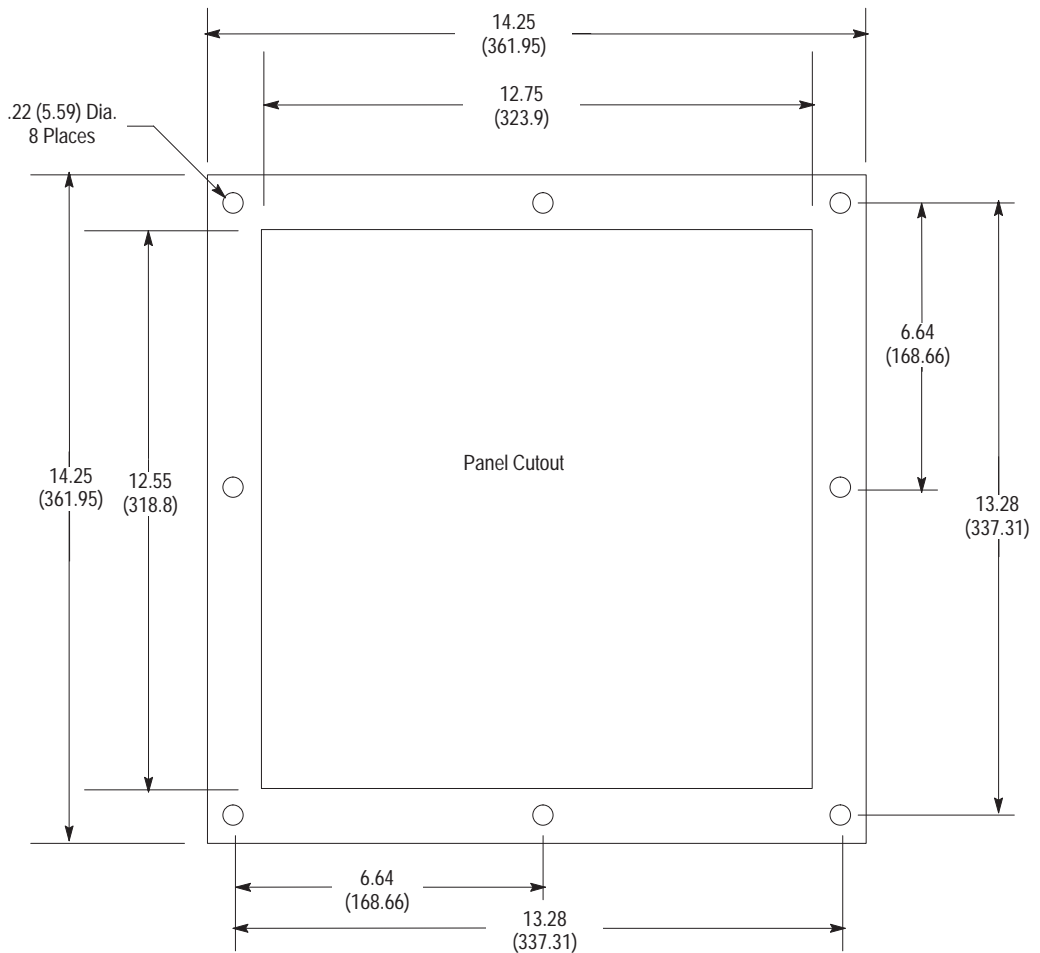
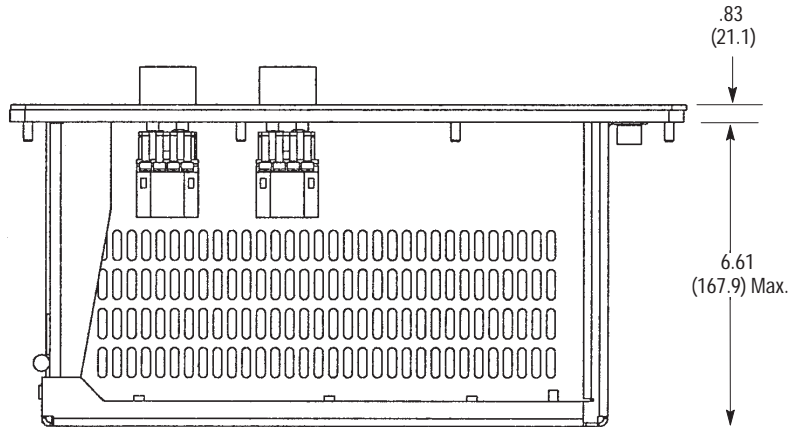

Figure 3.5  
Depth Dimensions in Inches (mm)  
800EM/EP Push Button Modules



2. Drill eight 0.22 in (5.59 mm) diameter holes for the top and bottom mounting brackets.
3. Slide the module through the opening and against a 1/16 in (1.6 mm) to 1/8 in (3.2 mm) thick enclosure.
4. Fasten the module in place with the enclosed locking nuts. Alternately tighten the nuts to a torque of 8 lb-in (0.908 N·m).

### 800EM/EP Fiberglass Enclosure Mounting

To mount a 16 or 32 Push Button 800EM/EP Fiberglass Enclosure Module:

1. Mark the locations of the four mounting holes. See Figure 3.6

Figure 3.6  
Fiberglass Enclosure Mounting Dimensions in Inches (mm)  
800EM/EP Push Button Modules

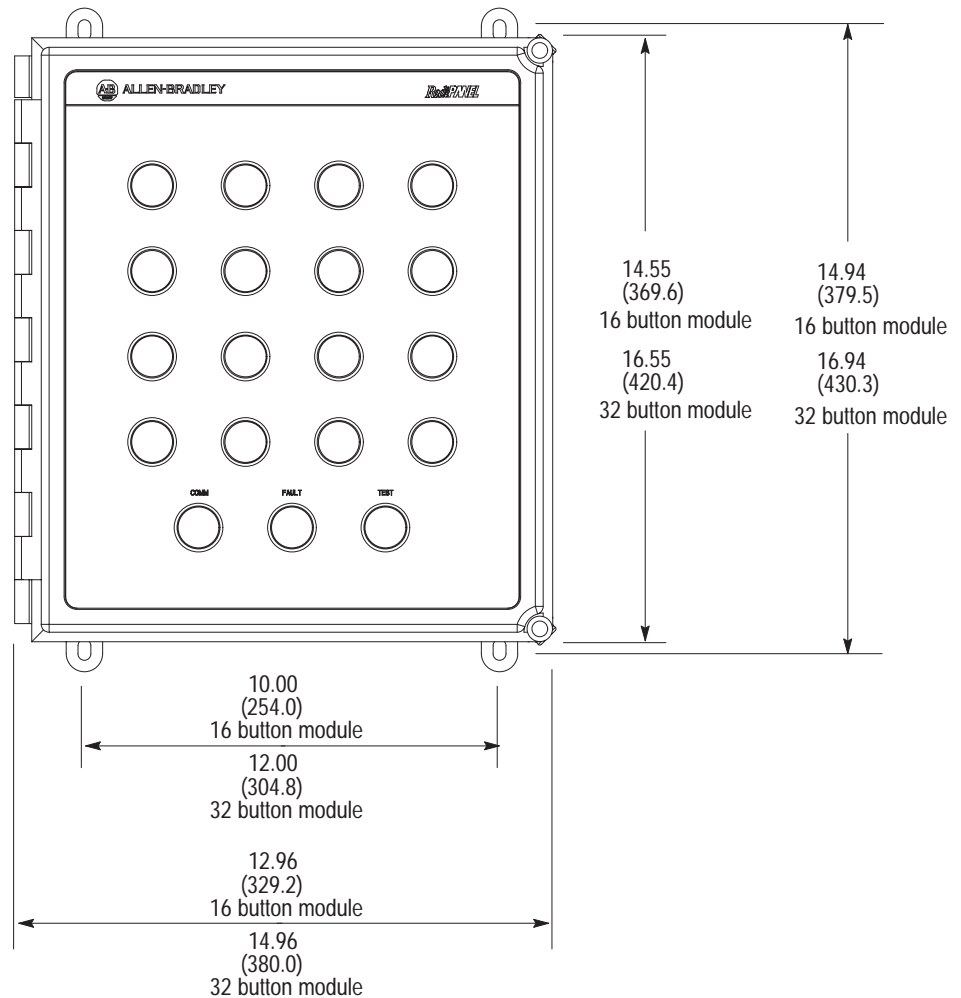

Fiberglass Enclosure

2. Drill four mounting holes suitable for your mounting hardware. The mounting flange on the enclosure will accommodate a fastener up to .50 in (12.7 mm) long x .31 in (7.9 mm) wide.
3. Secure the enclosure with the fastening hardware.

## 800EM/EP Steel Enclosure Mounting

### To mount a 16 or 32 Push Button 800EM/EP Steel Enclosure Module:

1. Mark the locations of the four mounting holes. See Figure 3.7.

Figure 3.7  
Steel Enclosure Mounting Dimensions in Inches (mm)  
800EM/EP Push Button Modules

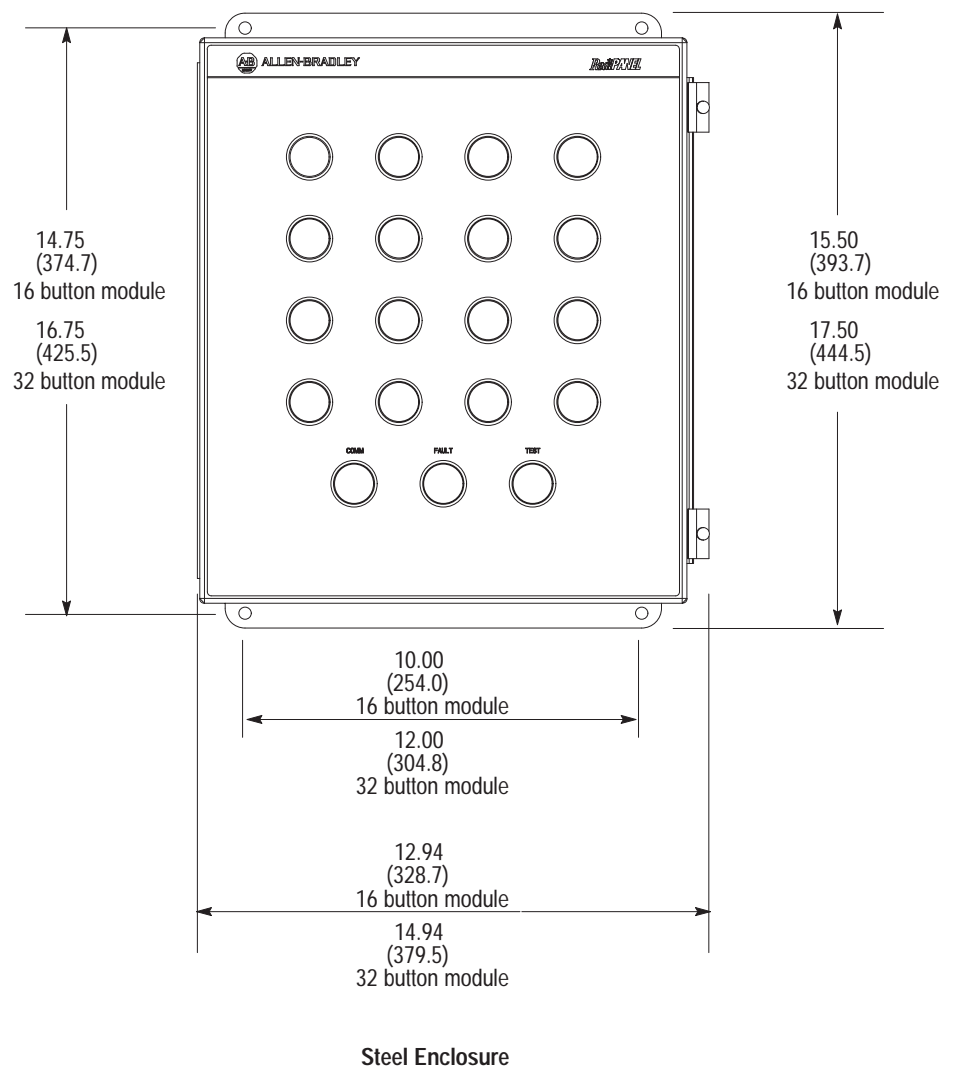

2. Drill four mounting holes suitable for your mounting hardware. The mounting flange on the enclosure will accommodate up to a .25 in (13 mm) diameter fastener.
3. Secure the enclosure with the fastening hardware.

## Installing the 800T/H Push Button Modules

This section shows how to install 32 and 16 Push Button 800T/H Modules:

### To install a 32 Push Button 800T/H Module:

1. Cut an opening in the panel approximately 14 inches (355.60mm) W x 25 inches (635.0mm) H. See Figure 3.8
2. Drill fourteen 0.22 inch diameter holes for the mounting studs.
3. Slide the module through the opening.
4. Fasten the module in place with the enclosed locking nuts.

Figure 3.8  
Mounting Dimensions in Inches (mm)  
32 Button 800T/H Modules

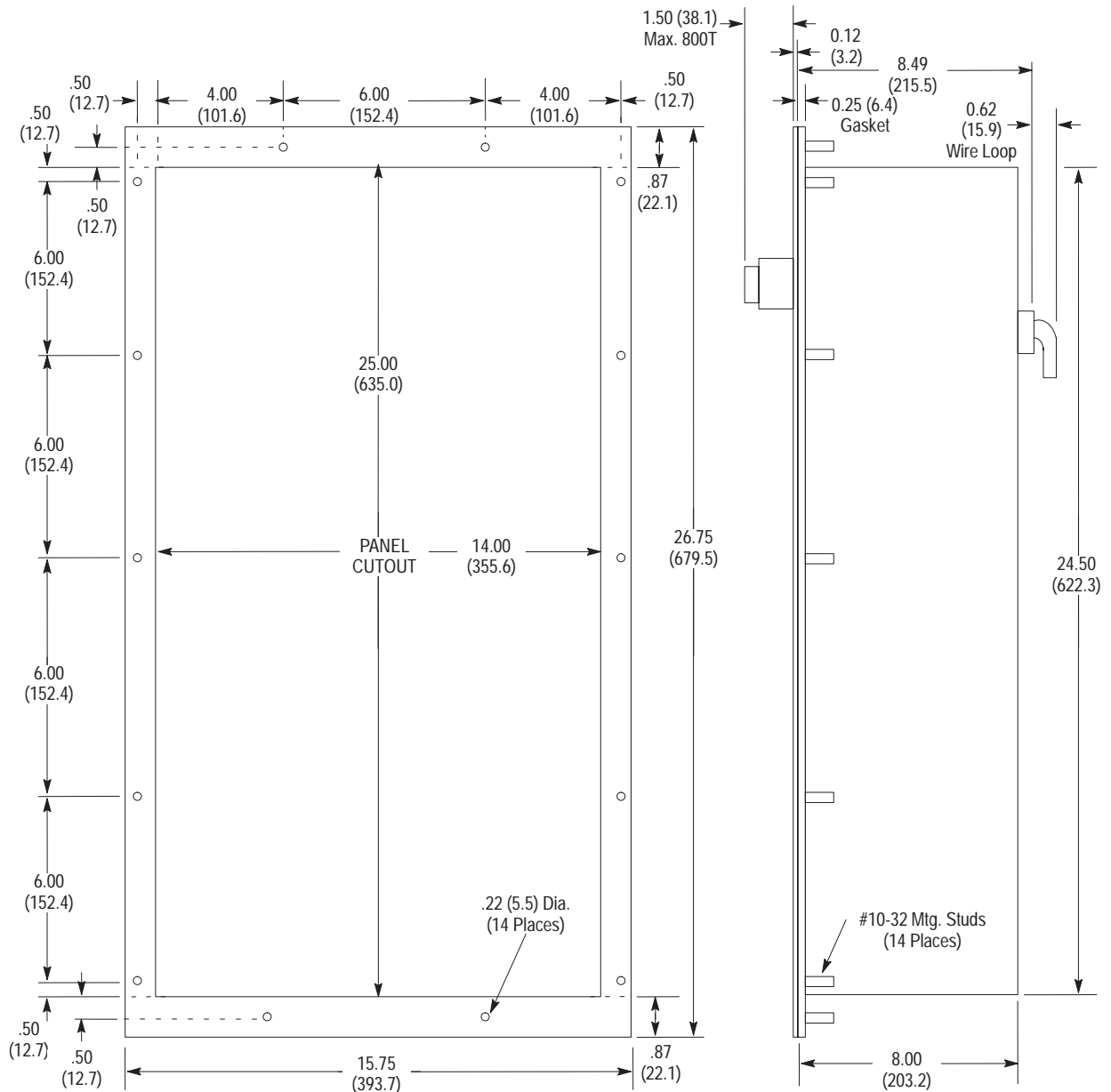

**To install a 16 Push Button 800T/H Module:**

1. Cut an opening in the panel approximately 14 inches (355.60mm) W x 15 inches (381.0mm) H. See Figure 3.9
2. Drill ten 0.22 inch diameter holes for the mounting studs.
3. Slide the module through the opening.
4. Fasten the module in place with the enclosed locking nuts.

**Figure 3.9**  
Mounting Dimensions in Inches (mm)  
16 Button 800T/H Modules

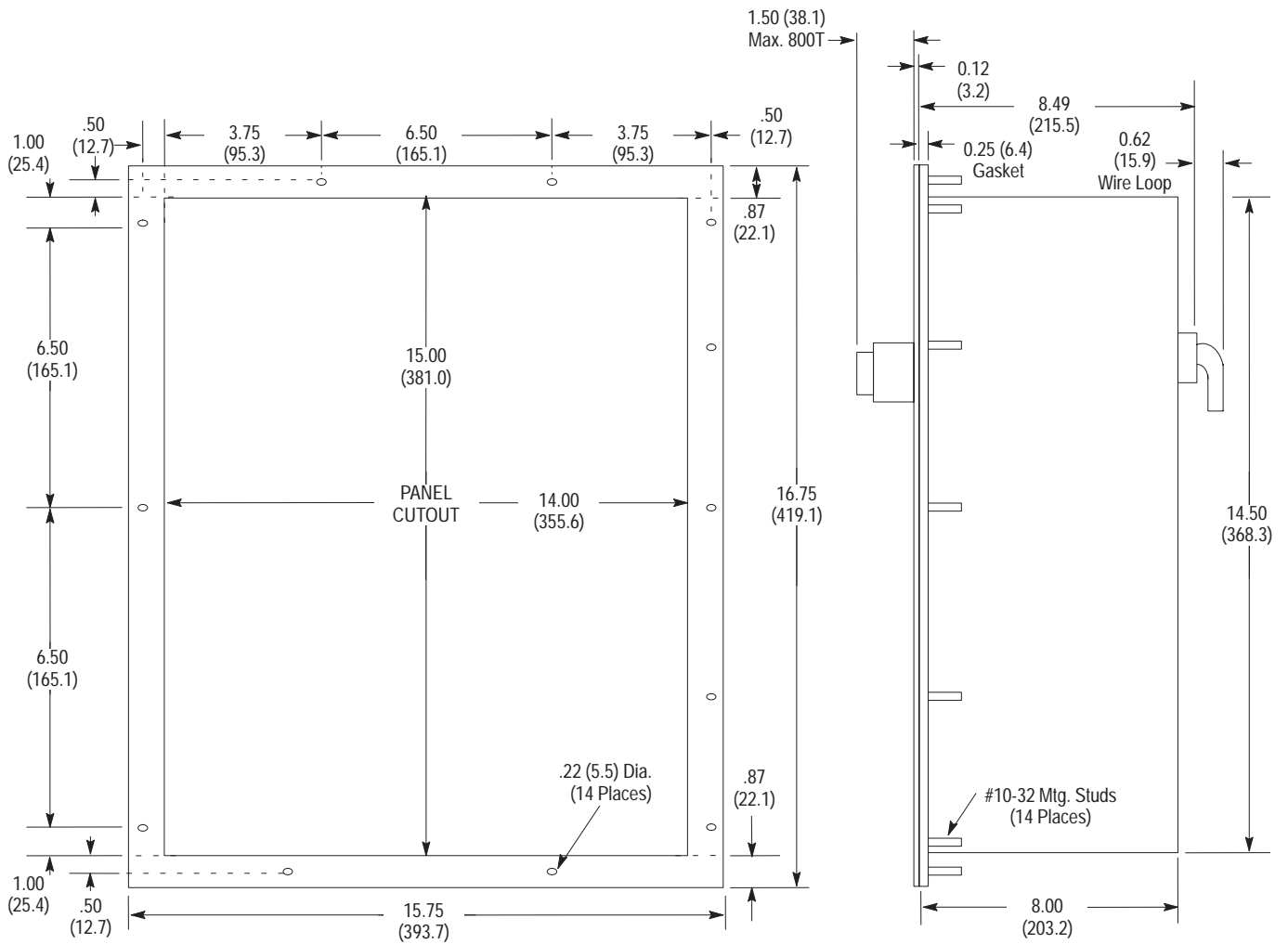

## Connecting to a Remote I/O Link

The Remote I/O link begins at the scanner module. The scanner modules and controllers impose physical and logical limitations on the link.

- The push button module is addressed like a remote I/O rack.
- The link can have up to 32 remote I/O devices. Refer to the appropriate PLC/SLC manual.
- The baud rate limits the maximum cable length (link distance):

Baud Rate	Cable Length (Maximum)
57.6 K	3,000 meters (10,000 feet)
115.2K	1,500 meters (5,000 feet)
230.4K	750 meters (2,500 feet)

The connection to the link is through the Serial Data Link cable (Catalog No. 1770-CD). This cable wires into the connector plug of the module.

## Connecting to a Scanner Module

Connect the Push Button Module to the scanner module with the Allen-Bradley I/O cable (Catalog No. 1770-CD) or Belden 9463.

A connector plug is provided with each Push Button Module. Wire the connector to the I/O cable as shown below.

Wiring Connections for Communications Cable

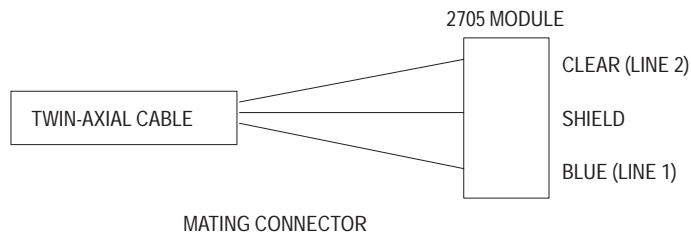

A Belden twin-axial cable links the RediPANEL Module to the Remote I/O communications. It wires the mating connector of the user's scanner module to the mating connector of the 2705 module. It is recommended that you terminate the first and last device on the remote I/O link. Install a 150 ohm, 1/2 watt resistor between lines 1 and 2 at both ends of the link for up to 16 devices and an 82 ohm, 1/2 watt resistor for up to 32 devices on the link.

## Programming the RediPANEL Modules

### Chapter Objectives

This chapter provides information on programming a RediPANEL module from a PLC or SLC controller. For additional programming information refer to the user manual for your controller or scanner module.

Section	Page
Module Bit Addresses	4-1
Using a PLC-2 with a 1772-SD2 Scanner	4-9
Using a PLC-2 with a Sub I/O Scanner	4-11
Using a PLC-5	4-14
Using a PLC-5 with a Sub I/O Scanner	4-15
Operating Cycles	4-19
Response Time	4-20
Handshake Mode	4-21
Flashing Lamp Example	4-23
SLC-5/02 Programming Example	4-24

### Module Bit Addresses

Each push button on the RediPANEL module is assigned a bit address. You need to know these addresses when writing your PLC program. These bit addresses are the same for all PLC processors.

This section shows the bit address locations for 8, 16 and 32 button modules.

#### Bit Addresses for 8 Button Modules (Type 800A only)

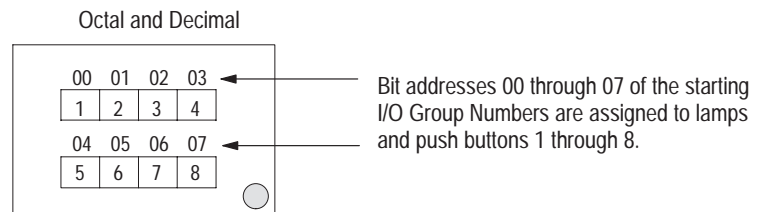

The PLC example below shows where these bit addresses appear in your instruction address.

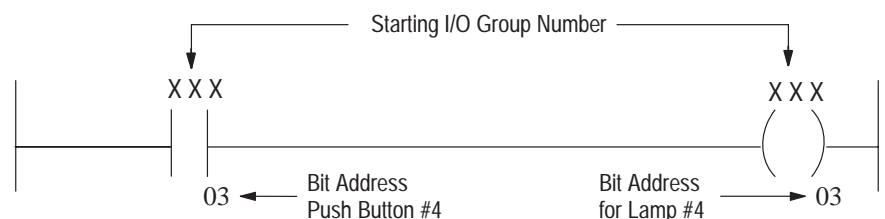



### Bit Addresses for 16 Button Modules

Bit Addresses for 16 Button  
800A and NEMA Type 4X Membrane Modules

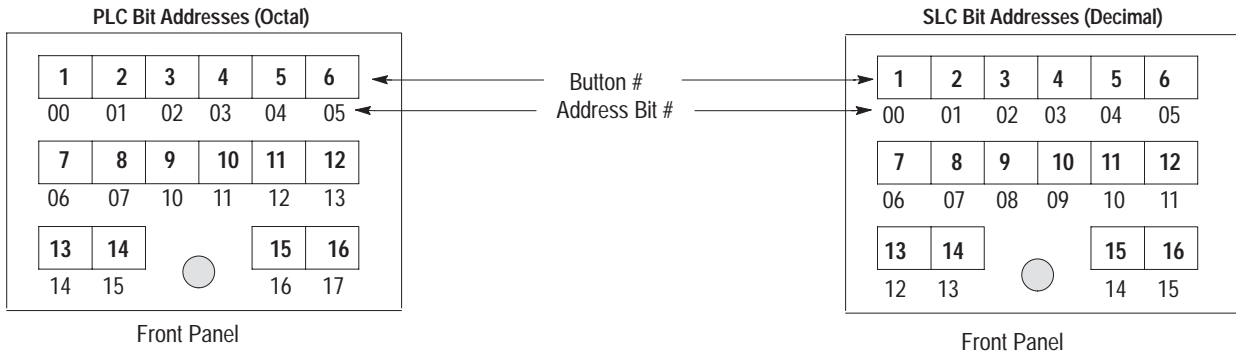

The PLC example below shows where these bit addresses appear in your instruction address.

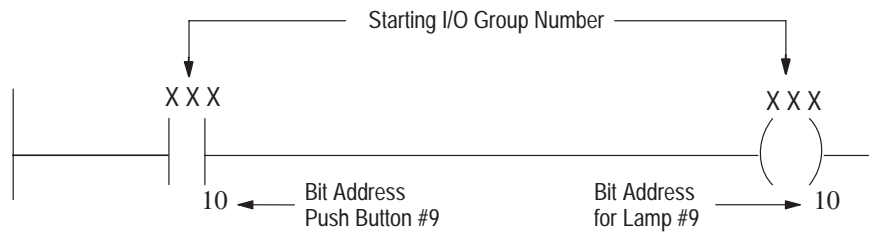

The SLC example below shows where these bit addresses appear in your instruction address.

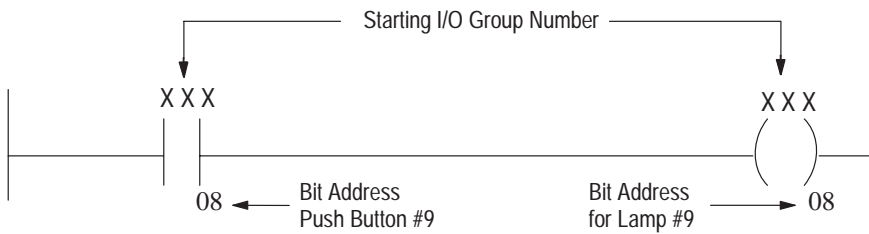

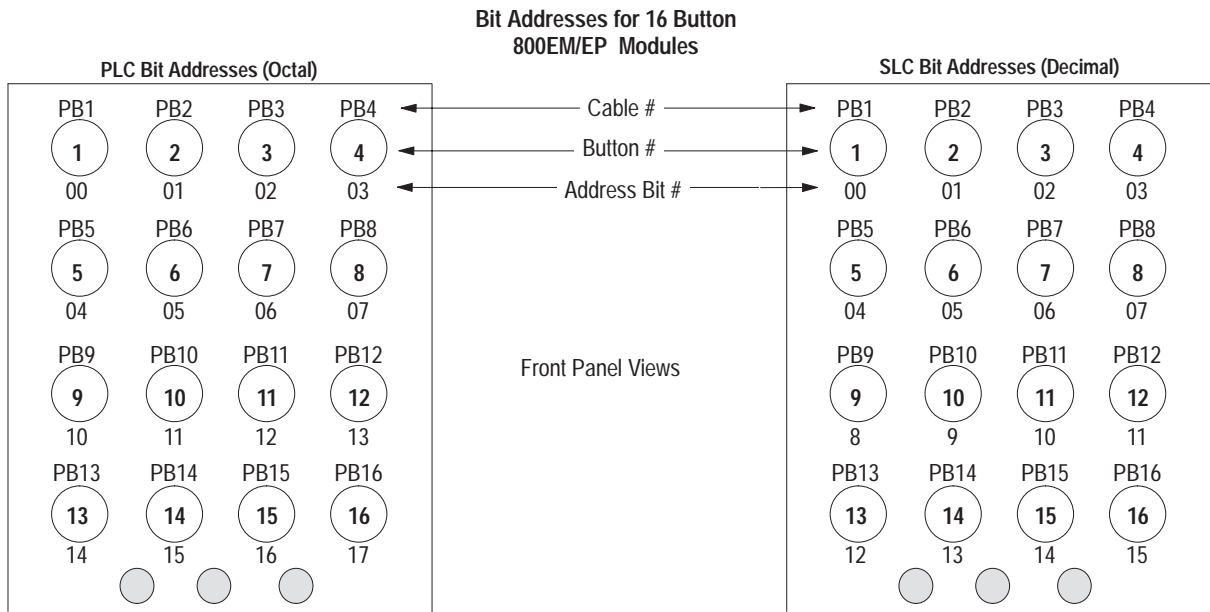

In 800EM/EP Push Button Modules, the cables that connect to the push buttons are marked PB1 – PB16 and diagnostics. This corresponds to PLC input and output bit locations 00-17.

In 800EM/EP Push Button Modules, the cables that connect to the push buttons are marked PB1 – PB16 and diagnostics. This corresponds to SLC input and output bit locations 00-15.

The PLC example below shows where these bit addresses appear in your instruction address.

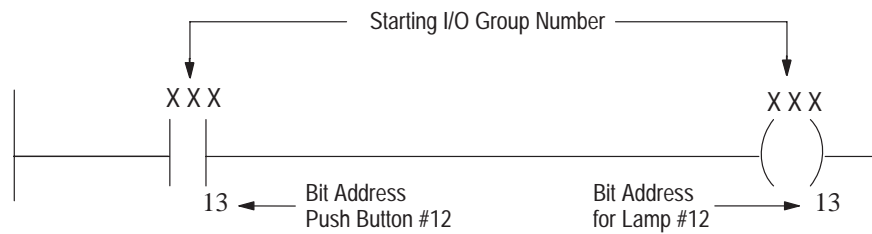

The SLC example below shows where these bit addresses appear in your instruction address.

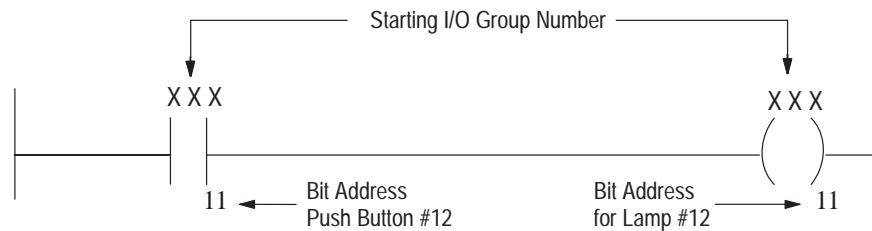

**Bit Addresses for 16 Button  
800T/H Modules**

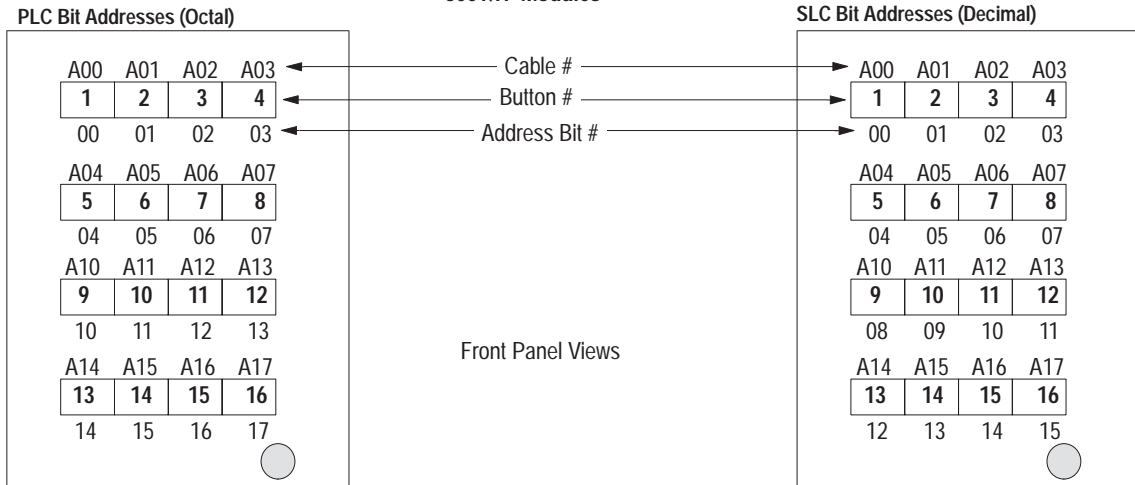

In 800T/H Push Button Modules, the cables that connect to the push buttons are marked A00-A17. This corresponds to PLC input and output bit locations 00-17.

In 800T/H Push Button Modules, the cables that connect to the push buttons are marked A00-A17. This corresponds to SLC input and output bit locations 00-15.

The PLC example below shows where these bit addresses appear in your instruction address.

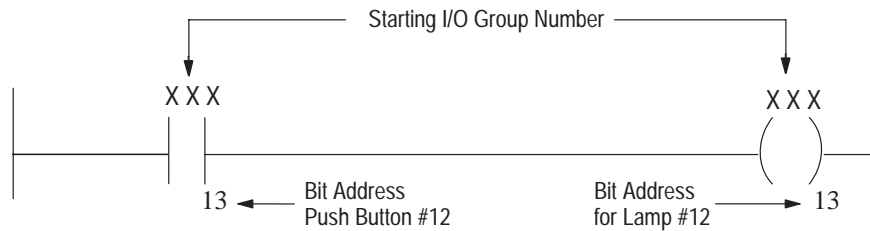

The SLC example below shows where these bit addresses appear in your instruction address.

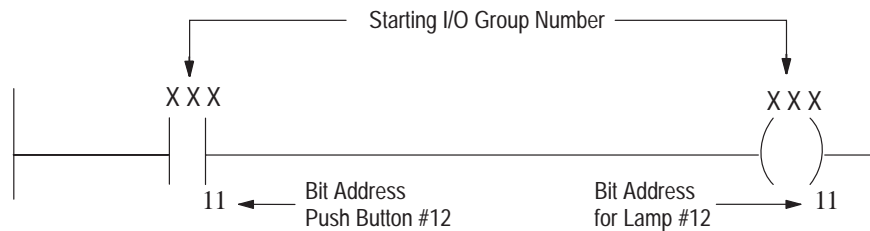

## Bit Addresses for 32 Button Modules

### Bit Addresses for 32 Button 800A Modules

#### PLC Bit Addresses (Octal)

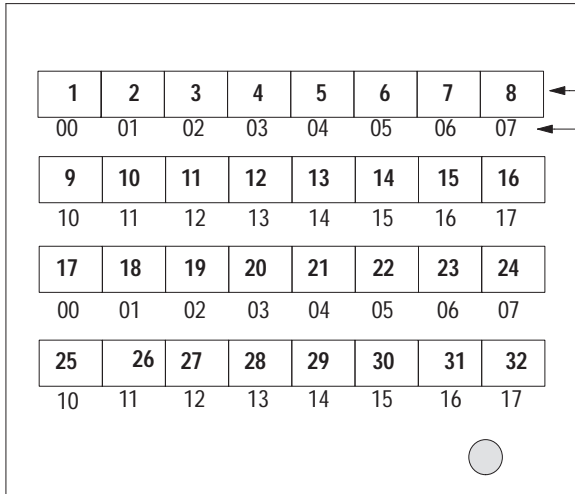

Front Panel

Button #  
Bit Address #

Two Module Groups (or words) of bit addresses are needed for the 32 push buttons:

- Bit addresses 00 through 07 and 10 through 17 of the starting I/O group are assigned to the lamps and push buttons 1 through 16.
- Bit addresses 00 through 07 and 10 through 17 of the next I/O group are assigned to the lamps and push buttons 17 through 32.

#### SLC Bit Addresses (Decimal)

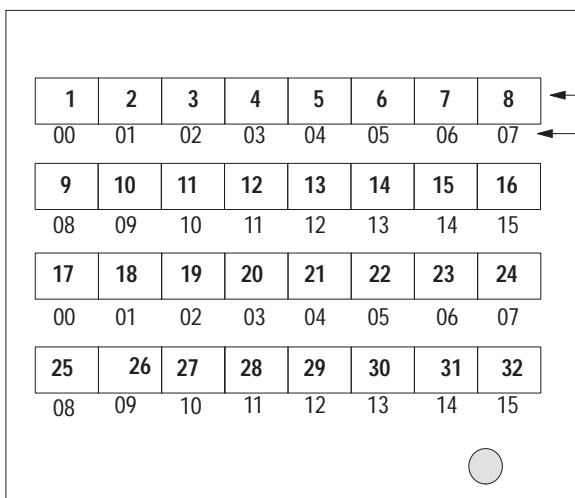

Front Panel

Button #  
Bit Address #

Two Module Groups (or words) of bit addresses are needed for the 32 push buttons:

- Bit addresses 00 through 15 of the starting I/O group are assigned to the lamps and push buttons 1 through 16.
- Bit addresses 00 through 15 of the next I/O group number are assigned to the lamps and push buttons 17 through 32.

See the next section for PLC and SLC addressing examples.

**Bit Addresses for 32 Button  
800EM/EP Modules**

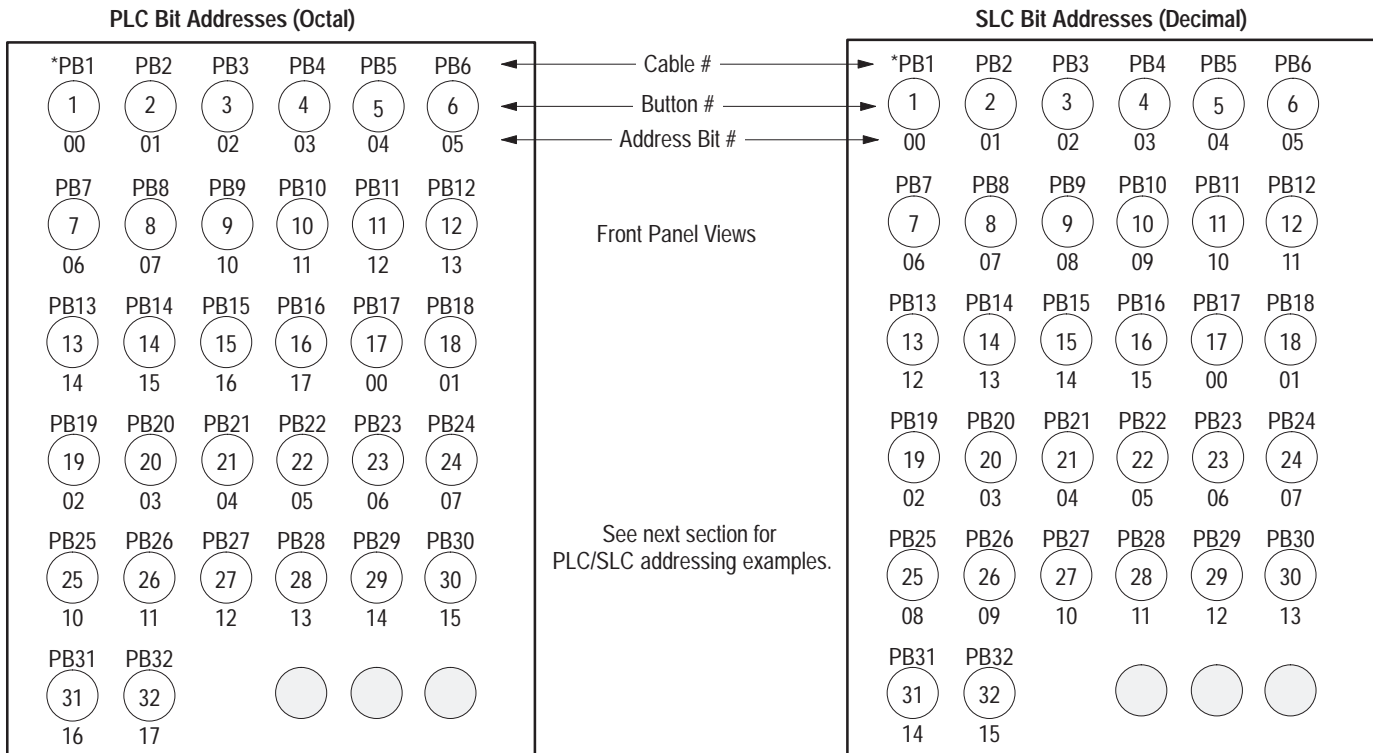

\* When using a PLC with 800EM/EP Push Button Modules, the cables that connect to the push buttons are marked PB1 – PB32 and diagnostics. This corresponds to PLC input and output bit locations 00 – 17.

\* When using an SLC with 800EM/EP Push Button Modules, the cables that connect to the push buttons are marked PB1 – PB32 and diagnostics. This corresponds to SLC input and output bit locations 00 – 15.

Two Module Groups (or words) of bit addresses are needed for the 32 push buttons:

- Bit addresses 00 through 07 and 10 through 17 of the starting I/O group are assigned to the lamps and push buttons 1 through 16.
- Bit addresses 00 through 07 and 10 through 17 of the next I/O group number are assigned to the lamps and push buttons 17 through 32.

Two Module Groups (or words) of bit addresses are needed for the 32 push buttons:

- Bit addresses 00 through 15 of the starting I/O group are assigned to the lamps and push buttons 1 through 16.
- Bit addresses 00 through 15 of the next I/O group number are assigned to the lamps and push buttons 17 through 32.

**Bit Addresses for 32 Button  
800T/H Modules**

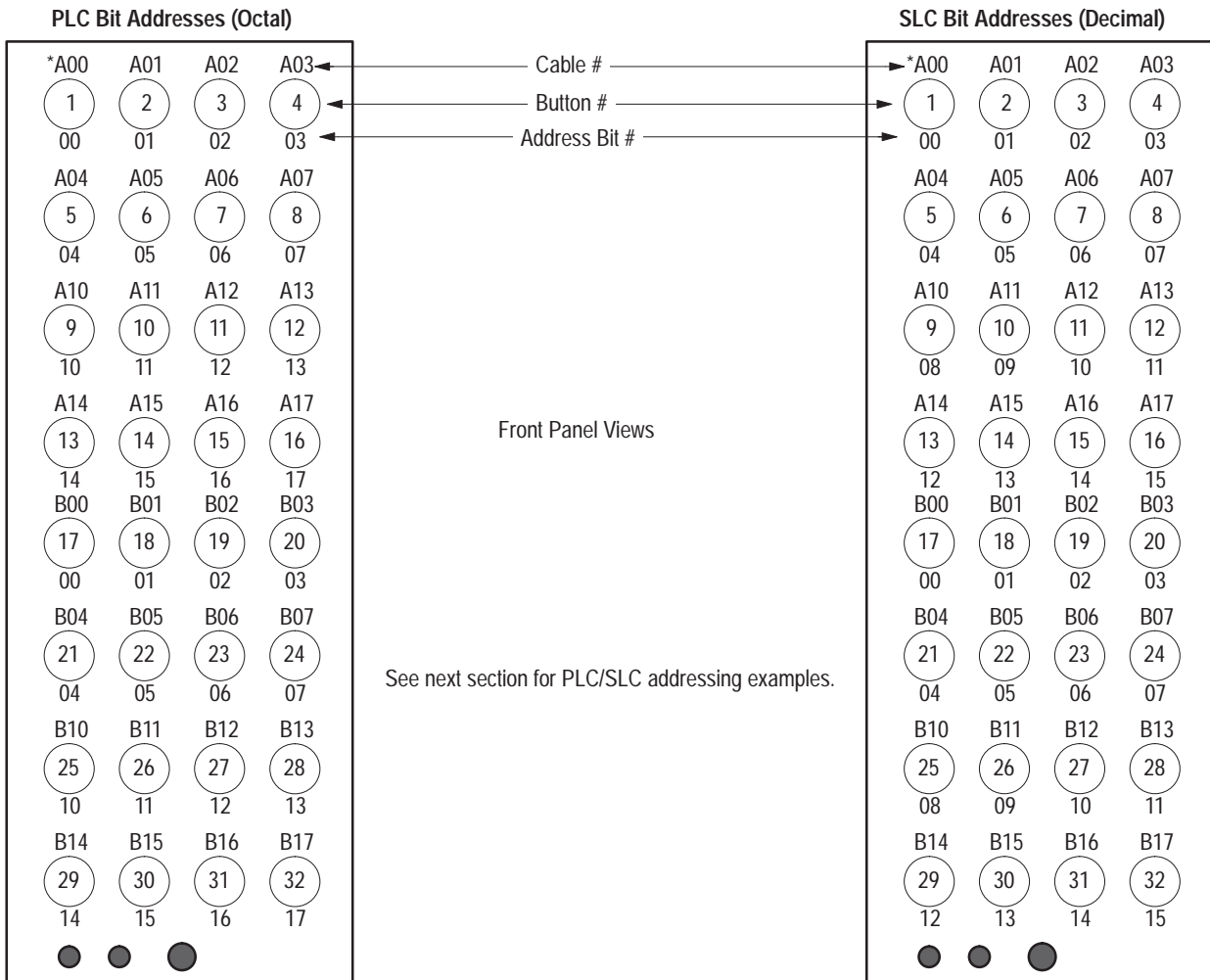

\* When using a PLC with 800T/H Push Button Modules, the cables that connect to the push buttons are marked A00-A17 & B00-B17. This corresponds to the input and output bit locations as shown. "A" refers to the 1st word; "B" refers to the 2nd word.

\* When using an SLC with 800T/H Push Button Modules, the cables that connect to the push buttons are marked A00-A17 & B00-B17. This corresponds to the input and output bit locations as shown. "A" refers to the 1st word; "B" refers to the 2nd word.

Two Module Groups (or words) of bit addresses are needed for the 32 push buttons:

- Bit addresses 00 through 07 and 10 through 17 of the starting I/O group are assigned to the lamps and push buttons 1 through 16.
- Bit addresses 00 through 07 and 10 through 17 of the next I/O group number are assigned to the lamps and push buttons 17 through 32.

Two Module Groups (or words) of bit addresses are needed for the 32 push buttons:

- Bit addresses 00 through 15 of the starting I/O group are assigned to the lamps and push buttons 1 through 16.
- Bit addresses 00 through 15 of the next I/O group number are assigned to the lamps and push buttons 17 through 32.

### Addressing Examples for 32 Button Modules

Below are PLC and SLC addressing examples for the 32 button modules.

The PLC example below shows where these bit addresses appear in your instruction address.

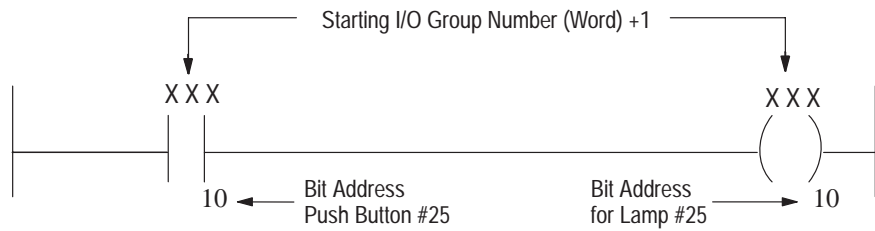
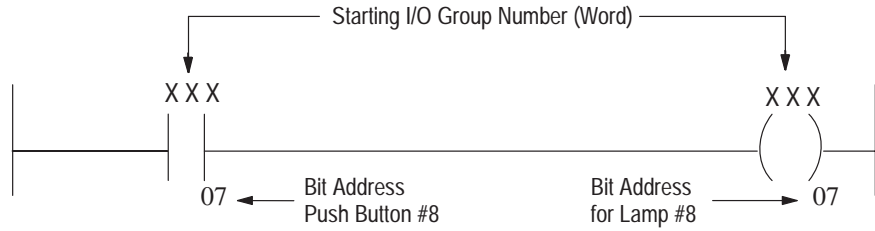

The SLC example below shows where these bit address will appear in your instruction address.

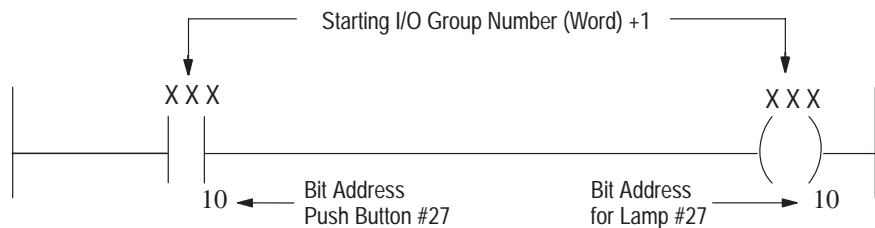
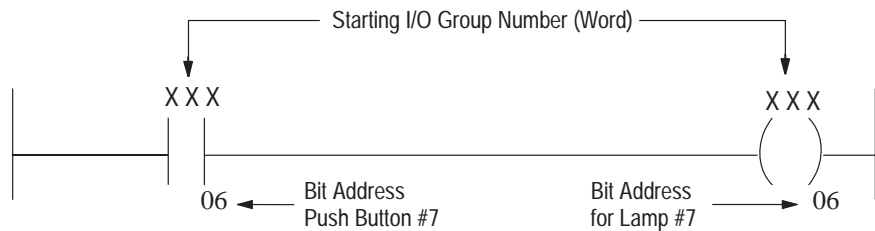

## Using a PLC-2 with a 1772-SD2 Scanner

When using a PLC-2/20 or 2/30 with a RediPANEL module, the system must include a 1772-SD2 Remote I/O Scanner/Distribution Panel (or a 1771-SN Sub I/O Scanner Module). The 1772-SD2 allows the PLCs to communicate with as many as 16 remote I/O devices in any configuration totaling 7 logical racks of I/O or less.

For details on 1771-SD2 wiring connections and switch settings, see Publication No. 1772-2.18 (The Remote I/O Scanner/Distribution Panel).

### Programming Example

Switch Bank #1 on the RediPANEL Module is set to use:

- Rack Address 2 (switch settings 1 - 6)
- Module Group 0 (switch settings 7 and 8)

Figure 4.1 shows typical address instructions and how these instructions are used in your PLC-2/20 or 2/30 program.

Figure 4.1  
PLC-2/20 or 2/30 Programming Example

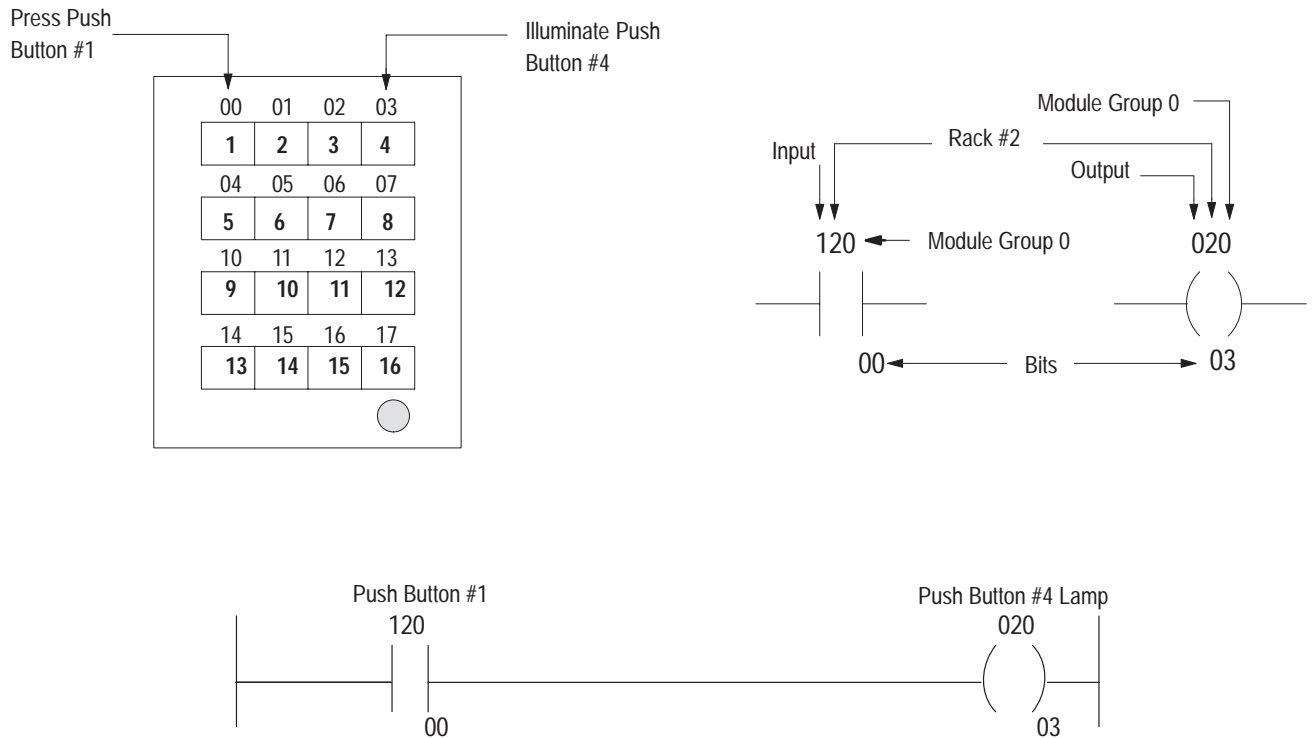



After entering the ladder logic, place the PLC in the RUN or REMOTE RUN mode to test your logic. Monitor the ON/OFF status of the input and output bits of the RediPANEL push button module by pressing [SEARCH] 53 followed by the address to monitor. This displays the input or output image table for that address.

The following figure shows what the I/O image table looks like when you press push button #1 for the previous example.

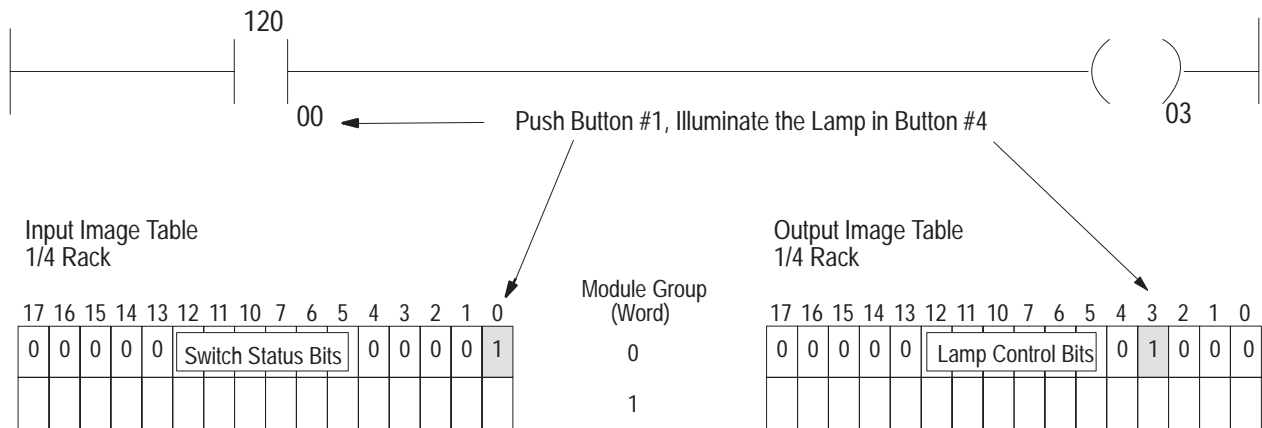

### Special Considerations

If the MODE SELECT DIP Switch #5 (Fault Table) on the 1772-SD2 is set to OFF, a remote I/O fault table is generated and remote I/O rack #2 must be declared used. These fault status bits are generated in the addresses associated with Module Groups 5 and 6 of remote I/O rack #2. (See Publication 1772-2.18).

## Using a PLC-2 with a Sub I/O Scanner

When using a PLC-2 processor with RediPANEL module, the system must contain a 1771-SN Sub I/O Scanner. Mini PLC-2 processors communicate with remote I/O using this Sub I/O Scanner. The Sub I/O Scanner is located in the same chassis as the mini PLC-2 and communicates with the PLC using block transfers. The 1771-SN Sub I/O Scanner looks like an intelligent I/O module to the PLC. You can also use Sub I/O Scanner in any chassis of a PLC-2/20 or 2/30 system.

The 1771-SN requires one PLC scan to receive the output data from the output image table and another PLC scan to send discrete input data to the input image table. Anything connected to the Sub I/O Scanner is scanned asynchronous to the PLC scan. The PLC then scans the Sub I/O Scanner during the I/O portion of the PLC scan. See the section on Operating Cycles.

### Block Transfer Example

Figure 4.2 shows an example of a block transfer between a Sub I/O Scanner module and a PLC.

Figure 4.2  
Block Transfer between Sub I/O Scanner and PLC-2

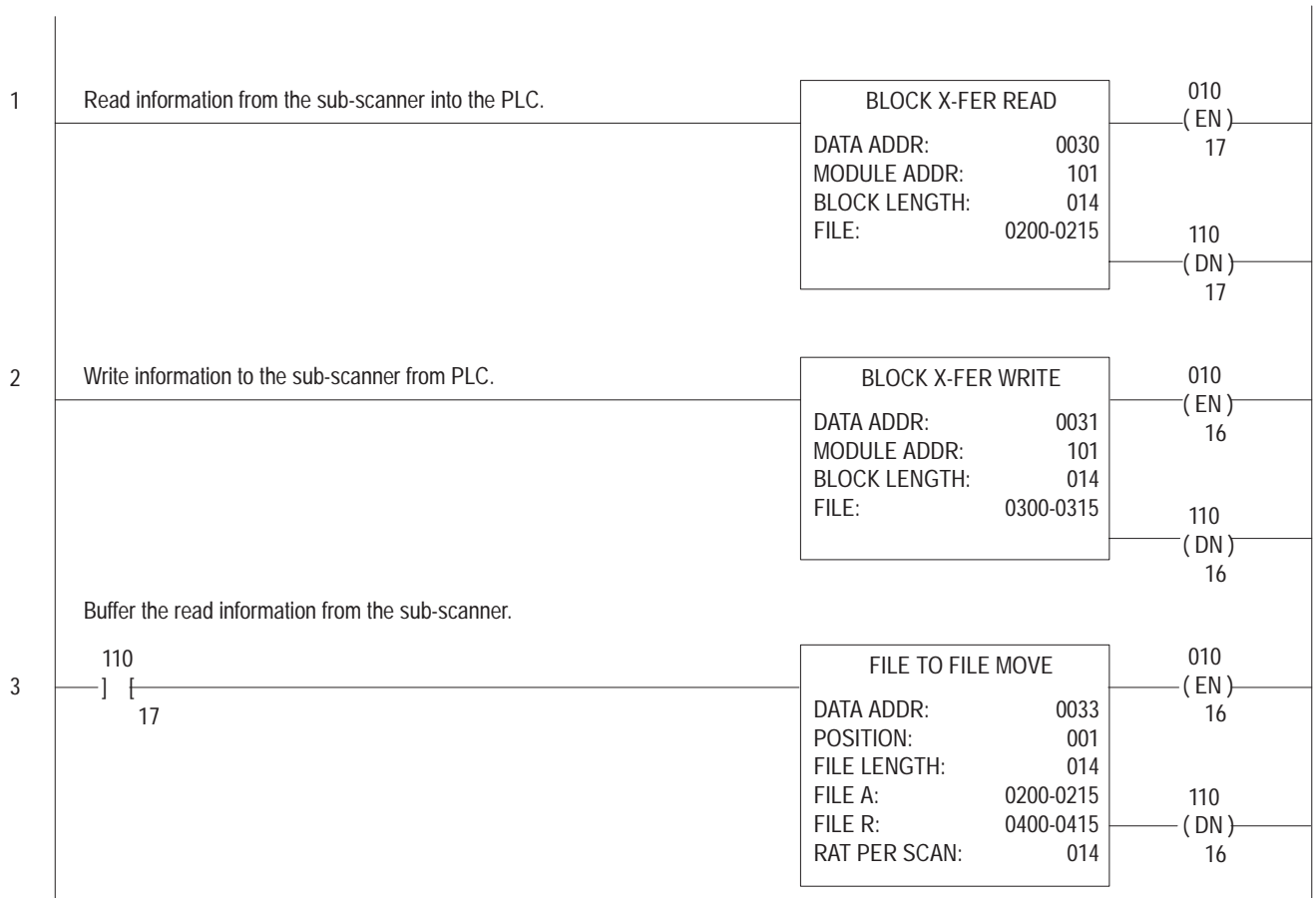

### **Ladder Logic Description**

The block transfer Read and Write instructions in the first two rungs move information between the Sub I/O Scanner and the PLC-2. You must assign the block transfer instructions to the first available timer/counter location. The length of the block transfer is equal to eight words (for the Sub I/O Scanner utility functions) plus 2 words for each 1/4 rack of I/O image table your module requires. For additional information on block transfers, see your PLC-2 User's Manual.

The File To File Move in rung 3 is triggered by the Done bit of the block transfer Read instruction. The File To File Move serves as a buffer for the block transfer Read data.

### **Block Transfer Read Instruction**

Reads input data from the Sub I/O Scanner and transfers that data to the Input Data File in the PLC starting with word 200. The File To File Move is a buffer for this information. The input data transferred to word files 200 - 215 will immediately (after Block Transfer Read *done* bit is set) move to word files 400 - 415. The input addresses will start at 4 instead of 1.

### **Block Transfer Write Instruction**

Writes output data to the Output Data File in the PLC (300 - 315) and then transfers it to the Sub I/O scanner. Output addresses start at 3 instead of 0.

### **Helpful Hint**

If you start your word files with hundred numbers, (200, 300 or 400), the rest of the instruction address is similar to hardwired I/O. The 2nd number in the address equals the rack number, the 3rd number equals the module group number (word), and the 4th and 5th numbers equal the bit location. For more details on the Sub I/O Scanner, refer to Sub I/O Scanner Module Product Data (Publication No. 1771-2.184).

Figure 4.3 shows instruction addresses for a Mini PLC-2 with a Sub I/O Scanner connected to a RediPANEL module. The module is configured as rack #1, module group 0.

**Figure 4.3**  
Remote I/O Addressing with a Sub I/O Scanner

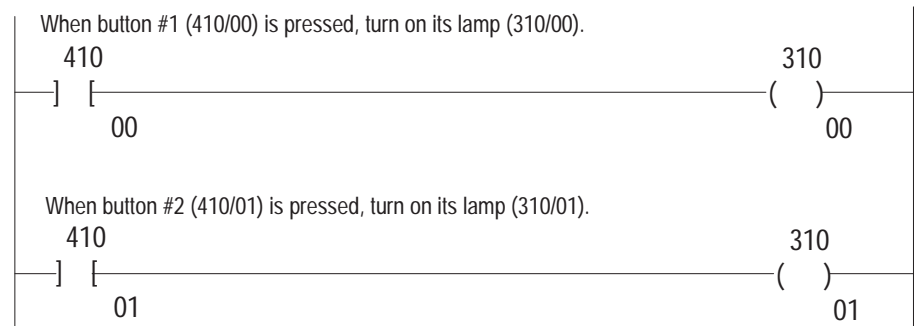

The following figure shows the I/O Data File configurations for the examples in Figures 4.2 and 4.3.

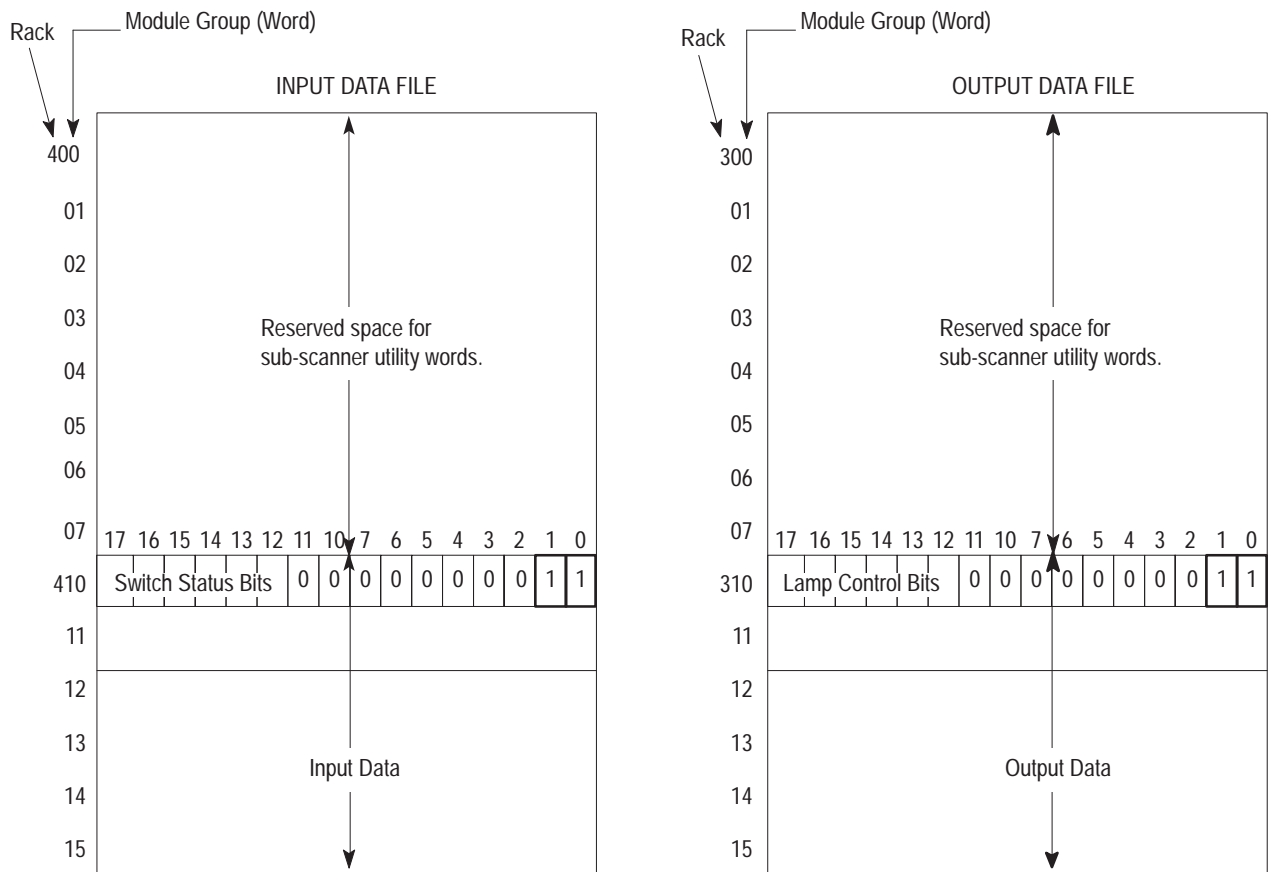

## Using a PLC-5

The PLC-5/15 and 5/25 processors have built-in remote I/O scanners. No additional hardware is required. Run the two conductor shielded cable (Blue Hose) from the RediPANEL to the remote I/O port of the PLC-5.

### To use the built-in scanner:

- Set switch 8 in DIP Switch Bank SW-1 on the processor to the OPEN, OFF or Scanner Mode position.
- Set the baud rate on the RediPANEL module to 57.6K baud for a PLC-5/15 or -5/25.

For an enhanced processor the baud rate can be 57.6K, 115.2K or 230.4K.

### Programming Example

Switch Bank #1 on the RediPANEL Module is set to use:

- Rack Address 3 (switch settings 1 - 6)
- Module Group 4 (switch settings 7 and 8)

Figure 4.4 shows typical address instructions and how these instructions are used in your PLC-5/15 or -5/25 program.

Figure 4.4  
PLC-5/15, -5/25 Programming Example

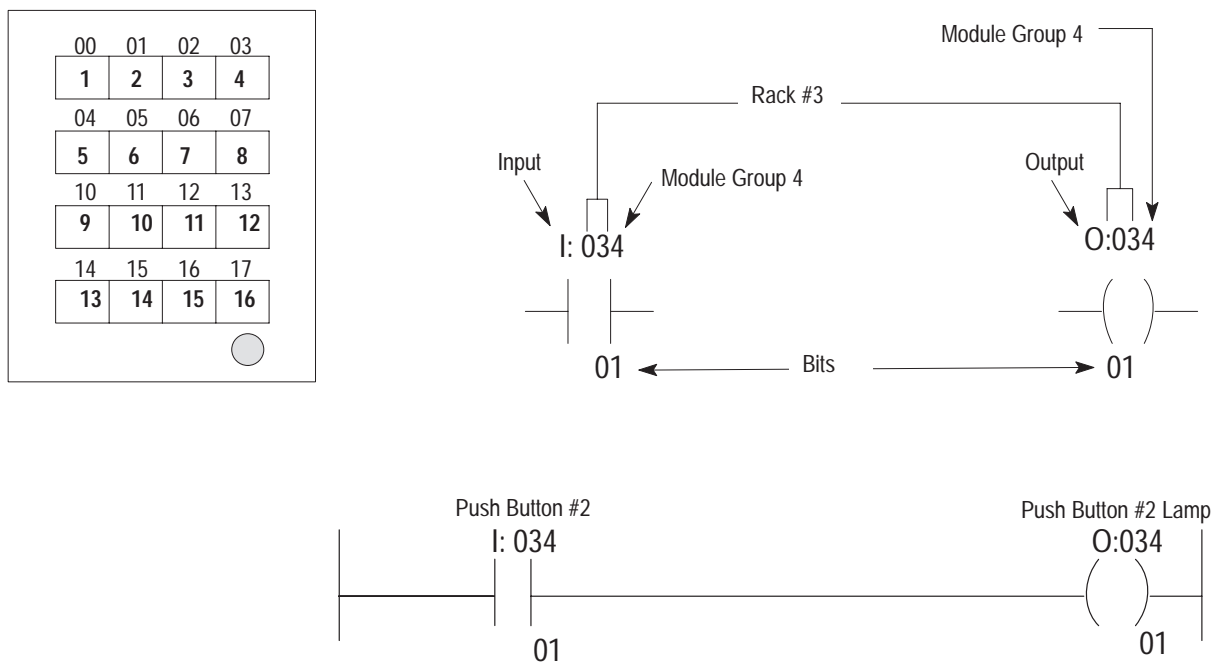

## Using a PLC-5 with a Sub I/O Scanner

Use a 1771-SN Sub I/O Scanner with a PLC-5 processor when the application requires more remote devices than the processor can accommodate. The Sub I/O Scanner module can communicate to 16 additional remote I/O devices. Locate the 1771-SN Sub I/O scanner in the same rack as the PLC-5 (the local rack) or in any one of the remote racks supported by the processor.

The PLC-5 communicates with the Sub I/O Scanner using block transfer read and write instructions. The block transfer read instruction reads input data from the Sub I/O Scanner and transfers that data to integer files in the PLC.

The block transfer write instruction writes output data to files in the PLC, then transfers that data to the Sub I/O Scanner. Input and output addresses begin at the integer file assigned to the block transfer instruction (instead of Input addresses starting with “I” and Output addresses starting with “O”). The rest of the input addresses depend on the specific integer file designated as the Data File in the block transfer read instruction. The rest of the output address depends on the specific integer file designated as the Data File in the block transfer write instruction.

Figure 4.5 an example of a bidirectional block transfer between a Sub I/O Scanner and a PLC-5.

Figure 4.5  
PLC-5 Block Transfer

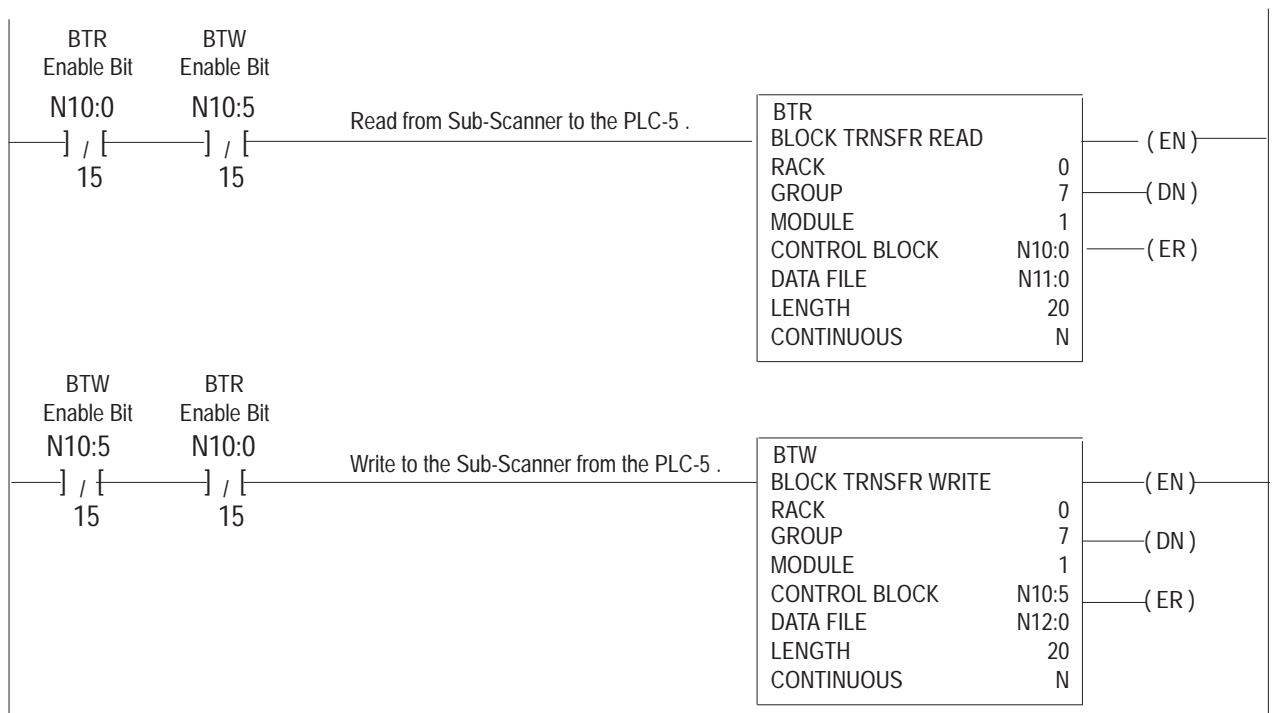

### Block Transfer Read and Write Instruction Parameters

Program all block transfer read and write instructions in the first rungs of your program. Each instruction transfers a maximum of 64 words between the processor and the sub I/O scanner. There are 8 words for the sub I/O scanner utility functions and 8 words for each of the 7 logical racks of RediPANELs the sub I/O scanner can communicate with.

The block transfer read and write instructions have certain parameters that you must enter. They are as follows:

Parameter	Description	Notes
Rack	Number of I/O rack in which the I/O scanner is located.	Consult PLC manual
Group	Number of I/O group in rack.	0 - 7
Module	Number of slot in I/O group in which the sub I/O scanner is located.	0 or 1
Control Block	5-word integer file that controls the instruction's operation. This is not the fil type for control elements, R	Enter the integer file address without the # symbol. For example, N7: (any integer file) not #N7:.
Data File	Address that the processor uses to transfer data (writing to or reading from).	Enter file address without the # symbol.
Length	Number of words the sub I/O scanner is transferring.	8 words (for Sub I/O Scanner utility functions) plus 2 words for each 1/4 rack of I/O the Sub I/O Scanner communicates with. The Length is 20 for the following example: 4 RediPANELS configured for 1/4 rack 1 RediPANEL configured for 1/2 rack to the Sub Scanner  8 words (Sub I/O Scanner utility functions) 8 words (2 words for each 1/4 RediPANEL) + 4 words (for one 1/2 rack RediPANEL) <u>20 words</u>
Continuous	Mode of instruction execution.	Enter N for No.

### Programming Example

The Sub I/O Scanner is in slot 1, module group 7 of the local I/O rack. The Sub I/O Scanner is connected to three RediPANEL 16 button modules, each configured for 1/4 rack.

- The Block Transfer Length is 14 (8 words for utility functions and 2 words for each of the 3 RediPANELS configured for 1/4 rack).
  - Data File address for the block transfer read starts at N11:0. This means that addresses for RediPANEL buttons start at N11:8.
- The Data File for the block transfer write starts at N12:0. This means addresses for the RediPANEL lamps start with N12:8.

Figure 4.6  
PLC-5/15 and Sub I/O Scanner Programming Example

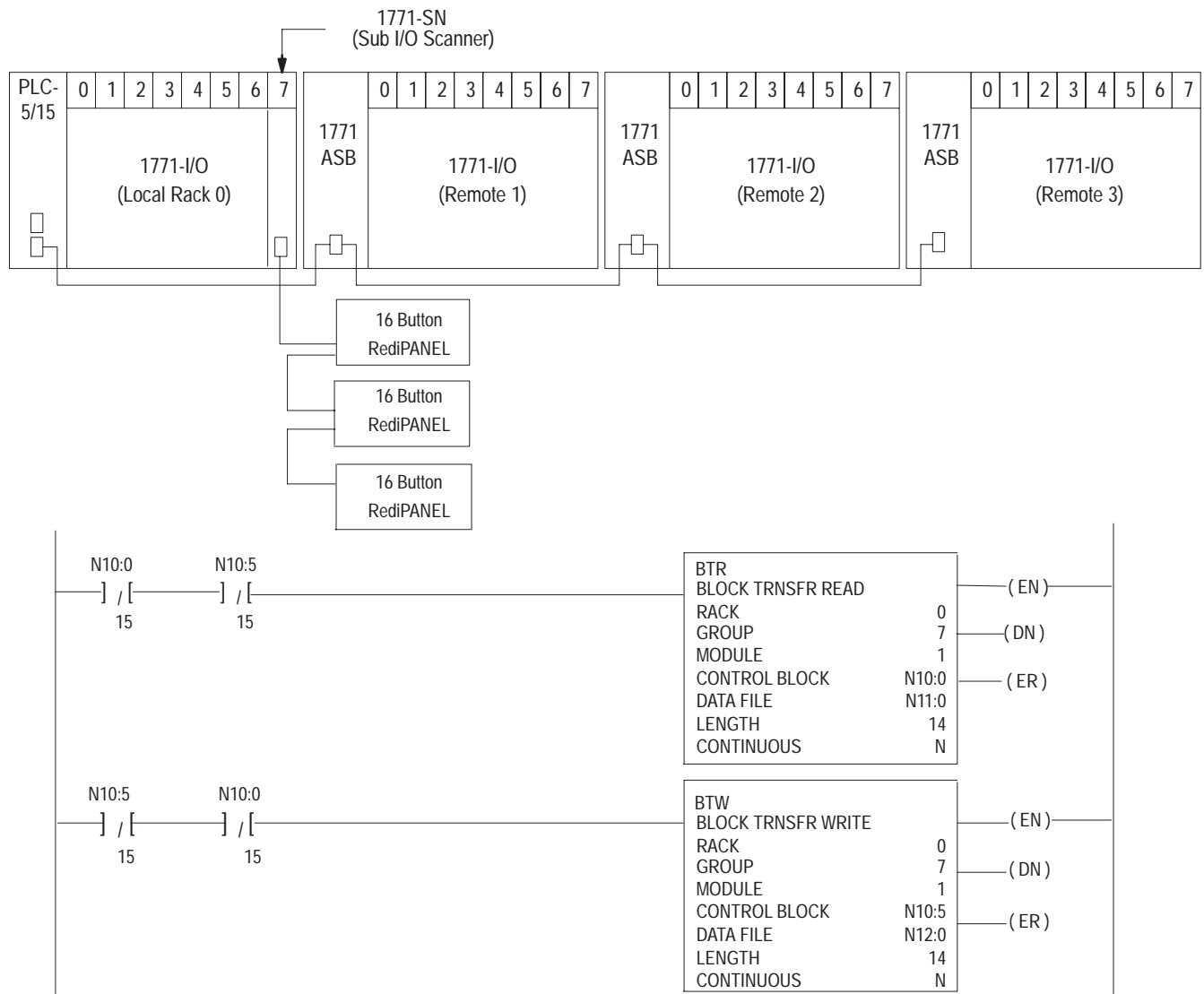
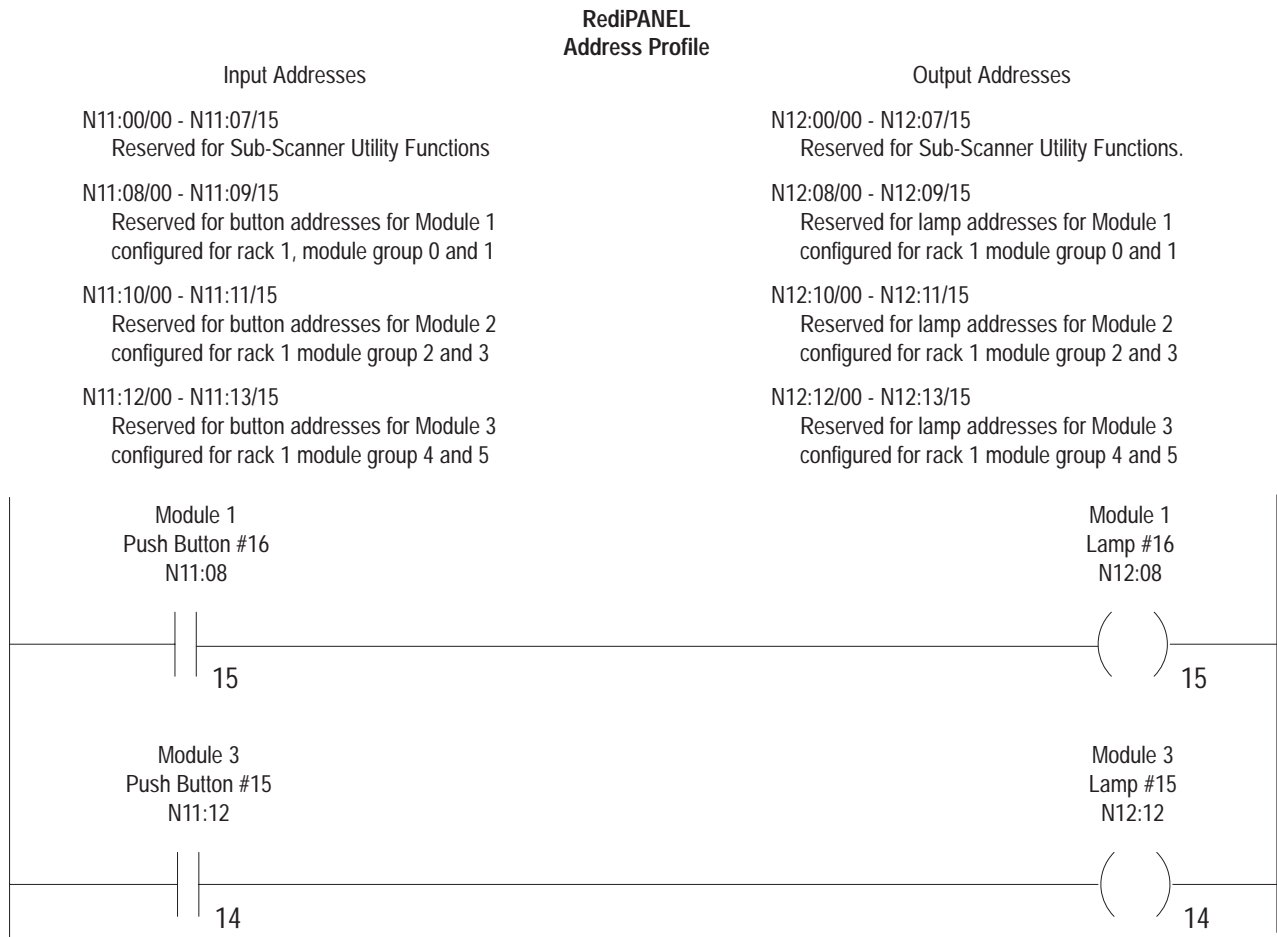



Figure 4.7 shows the instruction addresses for the RediPANEL Module configuration in Figure 4.6. The first 8 words of files N11 and N12 are reserved for the Sub I/O Scanner utility functions.

**Figure 4.7**  
PLC-5/15 and Sub I/O Scanner Ladder Logic Example



## Operating Cycles

The figure below illustrates a single operating scan or cycle of a PLC processor.

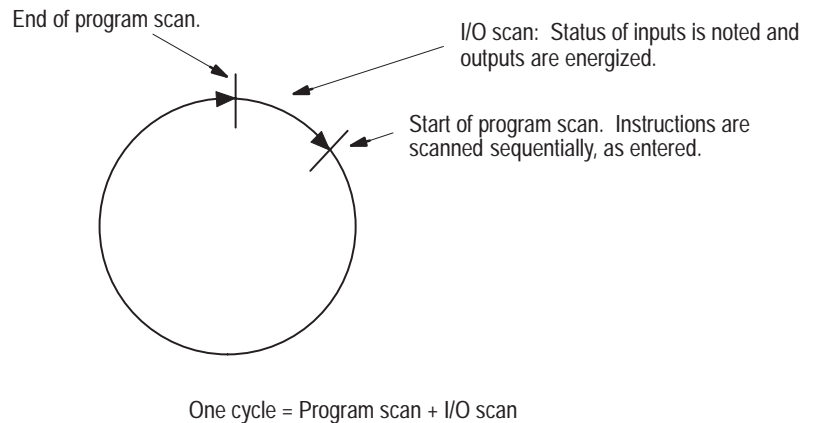

On power up, the processor begins a scan of the user program.

- The PLC scans the input/output (I/O) devices to determine their status.
- During the I/O update scan, the PLC communicates with the scanner.
- The scanner performs a remote I/O scan, asynchronous to the PLC's scan. The I/O chassis connected to the scanner are scanned in sequential order according to the I/O rack number, regardless of I/O channel.

The remote I/O scan time varies according to the amount of I/O data change taking place. Data from the input devices is transferred to the PLC's input image table and data from the PLC's output image table is transferred to the output devices. After completing the I/O scan, the processor begins the program scan. At this time, all ladder logic program instructions are scanned and executed in the order in which they were entered.

The I/O scan and the program scan are performed one after the other. The operating cycle is the total time required for both the I/O scan and the program scan.

The sections on Response Time and Handshake Mode cover the importance of timing in the program portion of the cycle in contrast to the I/O portion.

## Response Time

Response time is the amount of time it takes the RediPANEL Module to respond to a depression of a button.

The RediPANEL Module uses the Scanner Module to tell the PLC when a button is pressed. The Scanner Module takes a maximum of 7.0 milliseconds to scan a device, unless there is electrical noise. A maximum of 16 physical devices may be connected to any single Scanner Module channel. The maximum time between reading button depressions is:

$$7.0 \text{ milliseconds/device} \times 16 \text{ devices} = 112 \text{ milliseconds}$$

The worst case occurs when a second button is pressed while a 64 word block transfer is pending. A calculation for this condition is:

$$0.5 \text{ milliseconds/word} \times 64 \text{ words} = 32 \text{ milliseconds}$$

When you add these two figures together, you get:

$$112 \text{ milliseconds} + 32 \text{ milliseconds} = 144 \text{ milliseconds}$$

Therefore, if a button is pressed, released and pressed again within 144 milliseconds, the second press is missed by the Scanner Module. To deal with the response time factor:

1. The RediPANEL Module maintains each press of a push button in the ON state for a minimum of 100 milliseconds (in the Timed Mode) or until it is recognized by the PLC (in the Handshake Mode).
2. The push button must be released for 50 milliseconds between presses or the second press is ignored.

## Handshake Mode

RediPANEL Modules have a standard TIMED feature that holds all push button depressions for a minimum of 100 milliseconds allowing the PLC to read the depression during its scan cycle. No programming is required. Most system configurations use this feature to insure data capture of a push button depression.

Handshaking is required only under certain conditions.

1. Lengthy scan times. Lengthy scan times occur when the block transfer instruction is used numerous times in the ladder program. Lengthy scan times also occur with large ladder programs.
2. When the remote I/O link is approaching its physical limitation of 16 devices (RediPANEL modules, keypad modules, remote I/O racks).

To select the Handshake feature, enable (set ON) the module's DIP switch 7 of Switch Bank #2. Setting this switch OFF, gives you the TIMED feature, which is the default setting. Chapter 2 discusses switch settings for mode configuration. Figure 2.3 refers to Handshake enable and disable settings.

**To use the Handshake feature, the PLC program must have a rung that accepts the handshake bit and allows communication to continue.** Figure 4.8 shows an example rung. Your PLC program must contain this rung or the module will not operate.

Figure 4.8  
Ladder Logic Handshake Rung



If handshake is enabled and the handshake rung is in the user's program, the RediPANEL module holds all push button input signals high for a minimum of one complete PLC program scan. The signal(s) remain high for one complete cycle of the handshake input bit. The handshake input and output signals continuously toggle independent of any push button closures. The handshake function is operational even if no push buttons have been pressed.

Figure 4.9 shows handshake timing diagrams. They are not precise timing diagrams. Timing varies from application to application and is dependent upon the number of remote I/O nodes, program scan time, etc.

**Figure 4.9**  
**Handshake Timing Diagrams**

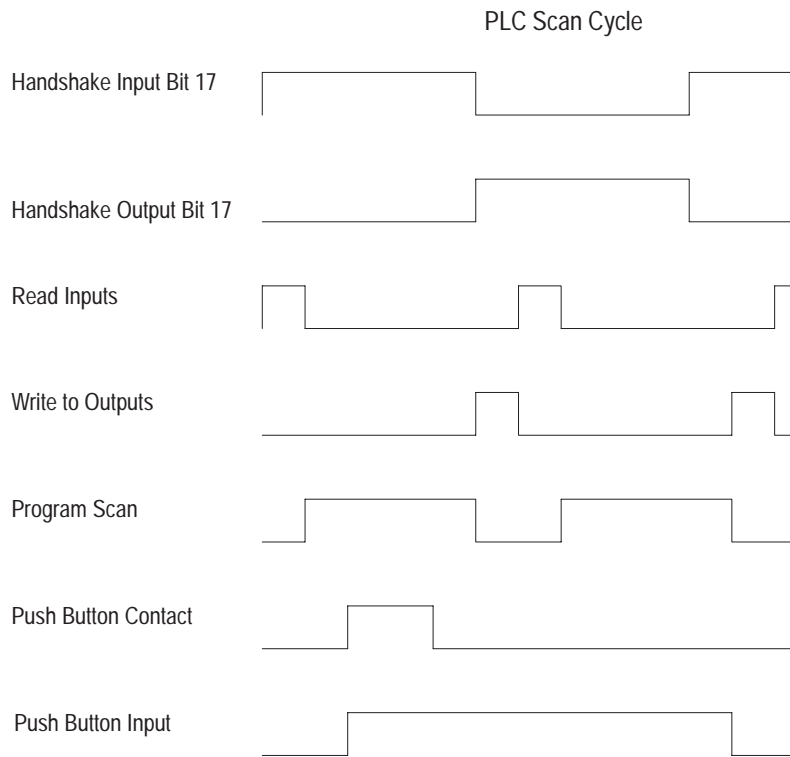

Handshake holds the push button input high even if the push button contact signal goes low.



## SLC 5/02 Programming Example

The example in this section interfaces a RediPANEL module with an SLC 5/02 controller. An alarm, connected to an output module, signals when communications with the RediPANEL are lost. The system consists of:

- SLC 5/02 Processor (Catalog No. 1747-L524) in slot 0
- Remote I/O Scanner (Catalog No. 1747-SN) in slot 1
- Output Module (Catalog No. 1746-OB8) in slot 2
- An alarm connected to the output module
- Bulletin 2705 RediPANEL Module

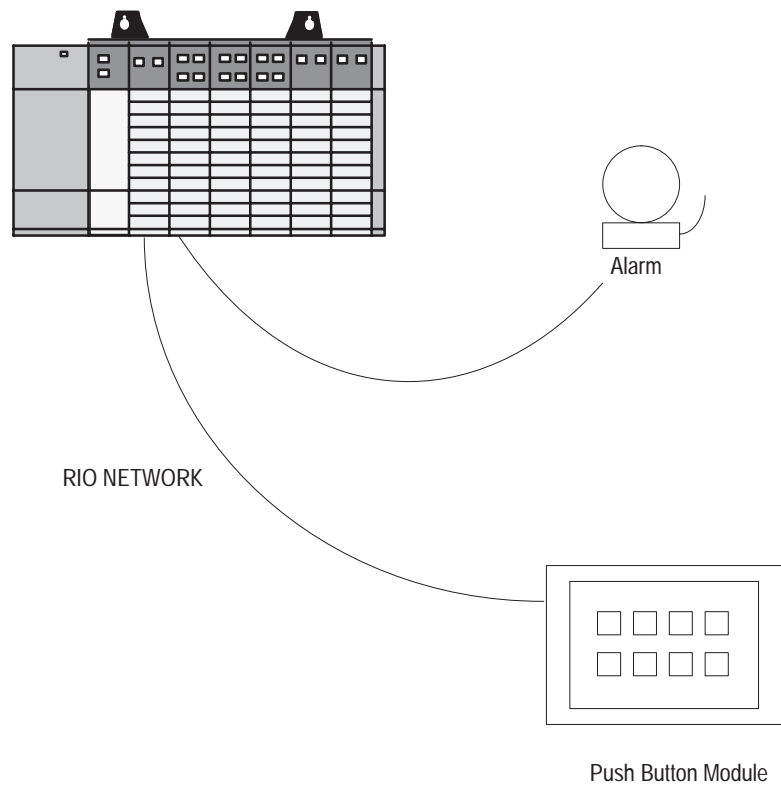

The 1747-SN Scanner can address four racks (0-3). 32 input words and 32 output words may be addressed in  $1/4$ ,  $1/2$ ,  $3/4$ , or full rack format. The scanner module can connect to 16 Remote I/O devices.

The G File contains the configuration information for communications between the RediPANEL module and the SLC 5/02.

- Word 0 of the G File indicates the I/O mix of the scanner. You cannot modify the contents of the G File's word 0.
- Word 1 of the G File defines the RIO rack address and starting group for each network device.
- Word 2 of the G File specifies the size of the network device.

You can only modify the contents of the G File in the offline mode. The file is then downloaded to the SLC processor.

**Example G File**

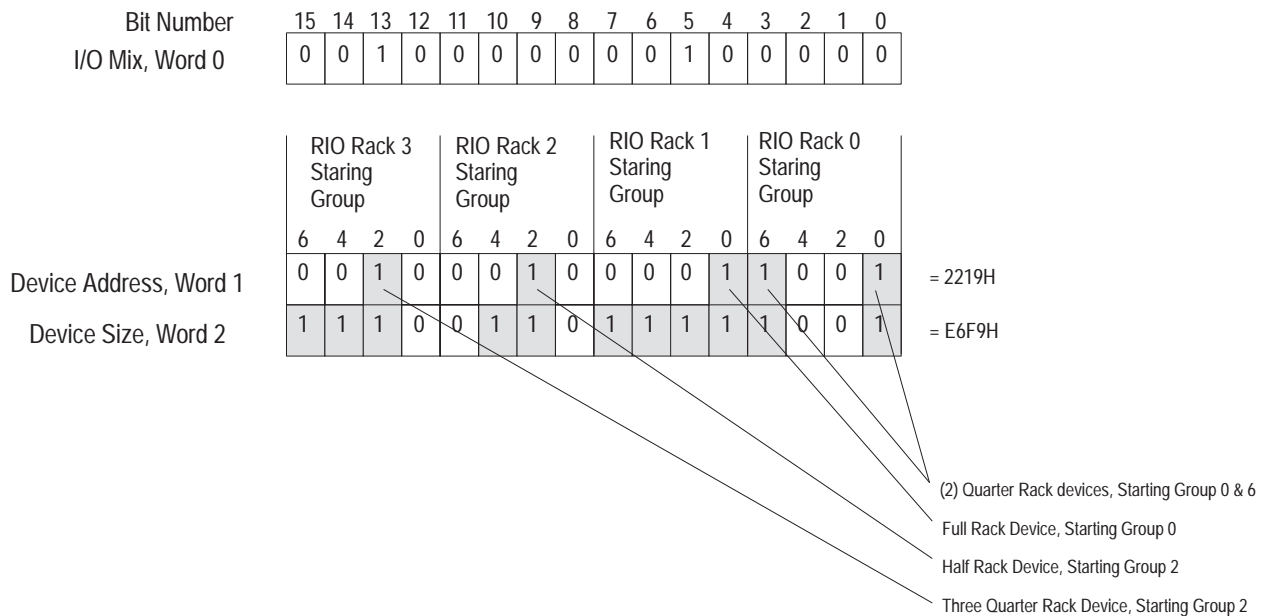

**Note:** The 1747-SN Scanner does not support block transfer functions. Refer to scanner user manual for additional information on scanner configuration.



The scanner input file is shown below. The output file is similar; it is addressed O:1.0 to O:1.3

		Bit Number																Input File	
		15	14	13	12	11	10	9	8	7	6	5	4	3	2	1	0		
<b>Rack 0</b>	<i>Rack 0 Group 0</i>	Word 0																I:1.0	} RediPANEL
	<i>Rack 0 Group 1</i>	Word 1																I:1.1	
	<i>Rack 0 Group 2</i>	Word 2																I:1.2	
	<i>Rack 0 Group 3</i>	Word 3																I:1.3	
	<i>Rack 0 Group 4</i>	Word 4																I:1.4	
	<i>Rack 0 Group 5</i>	Word 5																I:1.5	
	<i>Rack 0 Group 6</i>	Word 6																I:1.6	
	<i>Rack 0 Group 7</i>	Word 7																I:1.7	
<b>Rack 1</b>	<i>Rack 1 Group 0</i>	Word 8																I:1.8	
	<i>Rack 1 Group 1</i>	Word 9																I:1.9	
	<i>Rack 1 Group 2</i>	Word 10																I:1.10	
	<i>Rack 1 Group 3</i>	Word 11																I:1.11	
	<i>Rack 1 Group 4</i>	Word 12																I:1.12	
	<i>Rack 1 Group 5</i>	Word 13																I:1.13	
	<i>Rack 1 Group 6</i>	Word 14																I:1.14	
	<i>Rack 1 Group 7</i>	Word 15																I:1.15	
<b>Rack 2</b>	<i>Rack 2 Group 0</i>	Word 16																I:1.16	
	<i>Rack 2 Group 1</i>	Word 17																I:1.17	
	<i>Rack 2 Group 2</i>	Word 18																I:1.18	
	<i>Rack 2 Group 3</i>	Word 19																I:1.19	
	<i>Rack 2 Group 4</i>	Word 20																I:1.20	
	<i>Rack 2 Group 5</i>	Word 21																I:1.21	
	<i>Rack 2 Group 6</i>	Word 22																I:1.22	
	<i>Rack 2 Group 7</i>	Word 23																I:1.23	
<b>Rack 3</b>	<i>Rack 3 Group 0</i>	Word 24																I:1.24	
	<i>Rack 3 Group 1</i>	Word 25																I:1.25	
	<i>Rack 3 Group 2</i>	Word 26																I:1.26	
	<i>Rack 3 Group 3</i>	Word 27																I:1.27	
	<i>Rack 3 Group 4</i>	Word 28																I:1.28	
	<i>Rack 3 Group 5</i>	Word 29																I:1.29	
	<i>Rack 3 Group 6</i>	Word 30																I:1.30	
	<i>Rack 3 Group 7</i>	Word 31																I:1.31	
		Bit Number (octal)																	
		17 <sub>8</sub>	16 <sub>8</sub>	15 <sub>8</sub>	14 <sub>8</sub>	13 <sub>8</sub>	12 <sub>8</sub>	11 <sub>8</sub>	10 <sub>8</sub>	7 <sub>8</sub>	6 <sub>8</sub>	5 <sub>8</sub>	4 <sub>8</sub>	3 <sub>8</sub>	2 <sub>8</sub>	1 <sub>8</sub>	0 <sub>8</sub>		

The BAUD rate is 115.2K. DIP. Switch 1 must be in the OFF position; DIP switch 2 must be ON.

The G file size is set to 3 using the Speciality I/O Configuration function. The M0 and M1 file sizes are set to 32 in the Advanced Set Up function.

Since only the first 4 words of the input and output files contain valid information, the scanned input and output words can be set to 4. Reducing the number of scanned input and output words decreases SLC scan time.

Configuration information is entered in the Modify G File function. Word 0 is reserved and cannot be modified. Word 1 indicates the starting address of the device, word 2 indicates its size.

## Address Conversion

The addresses for the Input and Output files are provided in an octal format. You must convert the bit addresses to decimal to accommodate the SLC 5/02.

Bit Address	MSB														LSB		
Decimal	15	14	13	12	11	10	9	8	7	6	5	4	3	2	1	0	SLC 5/02
Octal	17	16	15	14	13	12	11	10	7	6	5	4	3	2	1	0	PLC5

## Maintenance and Troubleshooting

### Chapter Objectives

This chapter contains the following sections.

Section	Page
Preventive Maintenance	5-1
Using the Fault Indicator	5-2
Using the COMM Indicator	5-3
Using the Push-to-Test Button	5-4
Removing the Back Panel of 800T/800H Push Button Modules	5-5
Basic Troubleshooting Questions	5-6

### Preventive Maintenance

The best maintenance technique is preventive maintenance. Observe the following guidelines to minimize malfunctions:

- Once a month, use the push-to-test button located on the front of the Push Button Module.
- Prevent accumulation of dust and dirt by:
  - Installing in a NEMA Type 12/13 or 4/4X enclosure
  - Keeping enclosure clean
  - Keeping enclosure doors closed
- Avoid hot spots by:
  - Maintaining minimum spacing
  - Not storing unnecessary articles in enclosure
- Periodically check for loose connections.



**ATTENTION:** To avoid shock hazard, remove incoming power before checking connections.

---

- Avoid electrical noise by:
  - Following the electrical guidelines discussed in Chapter 6
  - Keeping enclosure doors closed

## Using the Fault Indicator

The red FAULT indicator (on front of module) indicates any software or hardware faults not related to communications. The Fault LED indicates one of 3 states:

- Off
- On
- Blinking

FAULT State	What it Means:	What to do:
OFF	<ol style="list-style-type: none"> <li>1. Module is operating correctly and no internal faults have been detected.</li> <li>2. Module is not receiving input power.</li> <li>3. Module is in the first second of the Push-to-Test cycle.</li> </ol>	<ol style="list-style-type: none"> <li>1. Nothing</li> <li>2. Nothing</li> <li>3. Nothing</li> </ol>
ON	<ol style="list-style-type: none"> <li>1. The FAULT indicator is on momentarily during the powerup sequence of the module.</li> <li>2. Push-to-Test button pushed and the module has been in the test mode for more than one second.</li> <li>3. Internal fault detected.</li> </ol>	<ol style="list-style-type: none"> <li>1. Nothing</li> <li>2. Nothing</li> <li>3. Cycle power to module. For 800A Push Button Modules, see the Push-to-Test button on page 5-4. If the fault continues, return the module to the factory for repair.</li> </ol>
Blinking	<ol style="list-style-type: none"> <li>1. DIP switch fault.</li> <li>2. Rack address and calculated size is invalid. For example, the module is addressed for the last module group, group 3, of a logical rack and its size was calculated as a half rack. The functional configurations which result in a size of two quarter racks are indicated in Chapter 4.</li> </ol>	<ol style="list-style-type: none"> <li>1. Check the following: <ul style="list-style-type: none"> <li>• Make sure you programmed the PLC for handshaking before enabling the handshake bit on the Push Button Module.</li> <li>• Make sure you enabled one of the functions of the Push Button Module (lamps or push buttons). If DIP switches 2,3 and 4 at switch location SW-2 are Off, the module is not capable of any functions.</li> </ul> </li> <li>2. Recalculate the rack size.</li> </ol>

### FAULT During Test Mode

If the FAULT indicator was ON before you pressed the push-to-test button, the LED will remain ON only if a fault is found. If the fault disappears and no lamps are flashing, the FAULT indicator will turn Off.

## Using the COMM Indicator

The green COMM indicator (on front of module) indicates communication faults or errors. The COMM LED indicates one of 3 states:

- Off
- On
- Blinking

COMM State	What it Means:	What to do:
OFF	<ol style="list-style-type: none"> <li>1. Module is not receiving input power.</li> <li>2. The Module is operating correctly, but no communication is occurring at this time.</li> <li>3. Module is in the first second of the Push-to-Test cycle.</li> <li>4. Module is the last rack, but the DIP switch indicating this state is not in the OFF position.</li> <li>5. The PLC, scanner, or sub I/O scanner is not configured to recognize the rack number of the Module.</li> <li>6. The baud rate of the module is not set to match the baud rate of the PLC's scanner.</li> </ol>	<ol style="list-style-type: none"> <li>1. Nothing</li> <li>2. Check the Remote I/O Link wiring; the blue and clear wires of your twin-axial cable may be interchanged.</li> <li>3. Nothing</li> <li>4. Change the DIP switch setting.</li> <li>5. See Chapter 2.</li> <li>6. Set the DIP switches to the correct baud rate.</li> </ol>
ON	<ol style="list-style-type: none"> <li>1. The Module is operating correctly with no communication faults.</li> <li>2. Push-to-Test button pushed and the module has been in the test mode for more than one second.</li> </ol>	<ol style="list-style-type: none"> <li>1. Nothing</li> <li>2. Nothing</li> </ol>
Blinking	<ol style="list-style-type: none"> <li>1. PLC is in the program or test mode and communications with the module have been established.</li> <li>2. The module rack size does not match the size of the configured PLC.</li> </ol>	<ol style="list-style-type: none"> <li>1. Nothing</li> <li>2. Reconfigure the module or PLC to a matching rack size.</li> </ol>

## Using the Push-to-Test Button

A TEST button is located on the front of the module. When you press and hold this button, the module enters test mode. Two tests are run.

### 1. Lamp / LED Test

All push button lamps and red/green LEDs turn OFF for one second, then illuminate for two seconds. If you press the TEST button when the test is done, the module continues with the Push Button Contact test.

### 2. Push Button Contact Test



Push buttons react as shown in Table 5A.  
Selector switches react as shown in Table 5B.

During TEST mode, the status of the lamps are *not* updated, and any push button presses are *not* transmitted to the PLC. The module exits test mode two seconds after you release test button.

Table 5.A  
Testing the Contacts of Illuminated Push Buttons

Description	Push Button Lamp			
	800A	NEMA 4	800EM/EP and 800T/H N.O. Contacts N.C. Contacts	
Non-actuated	ON	ON	ON	OFF
Actuated	OFF	OFF	OFF	ON
Contact Failure	Flashing	–	–	–

Table 5.B  
Testing the Contacts of Illuminated Selector Switches

Contact A	Lamp	Typical Example 800T-JR2KB7AXZ3
Open	ON	 or 
Closed	Off	

To test 4 position selector switch inputs and other non-illuminated push button and selector switch inputs, release the TEST button on the module and examine the corresponding Input Image Table locations while operating. **Make sure the controller is in TEST mode before operating buttons.**

### Additional Test for 800A Push Button Modules

Hold the push-to-test button in while power is applied to module. If a push button causes a fault, the lamp in that push button will flash.

## Removing the Back Panel of RediPANEL 800T/H Modules

The RediPANEL 800T/H Modules have removable back panels. The module's electronics are mounted to the back panel. If a failure occurs, swap the back panel for another with operating electronics. Return the failed back panel to the factory for repair.

### To remove the back panel:

1. Disconnect power to RediPANEL and external wiring.
2. Unplug input power terminal block.
3. Remove external wires from the unit.
4. Unplug the remote I/O connector.
5. Loosen screws on the back of the unit.
6. Open back panel.



**ATTENTION:** Back panel may fall open if not secured or supported.

---

7. Disconnect all push button cables: A0-A17 (B0-B17).
8. Disconnect cable attached to the board on the front panel which contains the indicator LED's.
9. Gather and secure (tape) cables to the plexiglass shield.
10. Remove E-ring from hinge pin (using pliers or grasping tool).
11. Lift or slide back panel off stationary side.



**ATTENTION:** May require oil on hinge if difficult to remove.

---

## Basic Troubleshooting Questions

Since the Push Button Module is part of an integrated system, you must evaluate the entire system when a fault is detected. Start your troubleshooting by asking these basic questions:

- Is the source power to the Push Button Module present?
- Do you have a communications light? If not, check your twin-axial cable wiring. The blue and clear wires may be interchanged.
- Is the rack address set properly? Refer to Chapter 2.
- Are the baud rates of the Push Button Module and the Scanner Module the same? Refer to Chapter 2.
- Is the Push Button Module the last in a series of modules, and has it been identified as the last rack? Refer to Chapter 2.
- Is the communication connector securely plugged in at both the Push Button Module end and the Scanner Module end?
- Have you changed the settings of any of the DIP switches? New DIP switch settings are not acknowledged until power is cycled. Refer to Chapter 2.
- On modules with a switch selectable power supply, is the 120/240 AC voltage switch position correct?
- If applicable, is the fuse properly installed and in working order?



## Specifications

### RediPANEL 800A Module

#### Electrical

Built-in Power Supply 90 to 264V AC, 47-63 Hz  
18 to 30V DC

#### Input Current and Power Ratings

	32 Buttons	16 Buttons	8 Buttons	On/Off
24V DC Input	2.1A, 50VA	1.25A, 30VA	0.83A, 20VA	All On
	0.83A, 20VA	0.58A, 14VA	0.46A, 11VA	All Off
120V AC Input	550 mAmps	360 mAmps	260 mAmps	All On
	260 mAmps	190 mAmps	135 mAmps	All Off

Lamps 12V DC, Catalog No. 800M-N16  
LEDs 12 Volts, Catalog No. 800T-N61R (Red)  
-N61G (Green)  
-N61A (Amber)

Communications Connector Standard 3-prong female connector  
(supplied with each module as Part No. 22112-046-03)

UL File / Guide Non-hazardous Locations: E56639 / NMTR  
Hazardous Locations: E10314 /N01V ①

CSA Non-hazardous Locations: LR62923 ①  
Hazardous Locations: LR11924

#### Mechanical

Enclosure NEMA Type 13

Configurations

8 Push Button Module 4 red, 4 green backlit buttons  
16 Push Button Module 6 red, 6 green, 4 amber backlit buttons  
Module is also available with membrane buttons:  
4 rows of 4 buttons with LED output indicators  
32 Push Button Module 8 red, 8 green, 8 amber, 8 clear (white) backlit buttons

Replacement Illuminated Push Button

8, 16 Push Button Units Catalog No. 800A-C2D 1  
32 Push Button Units Catalog No. 800A-C2C 12

Dimensions

Length 9.25 inch (234.95 mm)  
Height 7.00 inch (177.8 mm)  
Depth 6.88 inch (174.75 mm)

Weight 9 lbs. (4.1 kg)

① Hazardous location RediPANELS approved for Class 1, Division 2, Group A, B, C, and D applications.

## RediPANEL 800A Module

### Communications

User Supplied Cable

I/O Cable, Catalog No. 1770-CD or  
Belden cable 9463 only

Baud Rates

57.6K, 115.2K, 230.4K

Maximum Distance

10,000 feet (3,000 meters) at 57.6K  
5,000 feet (1,500 meters) at 115.2K  
2,500 feet (750 meters) at 230.4K

Remote I/O Serial Data Link

Communicates with the Allen-Bradley PLC controllers  
using the following scanner modules:

Scanner	PLC
1771-SN	PLC-2/05, -2/15, -2/16, -2/17
	PLC-5/12
1747-SN	SLC-5/02, -5/03
1772-SD2 (Rev. 3 or later)	PLC-2/30
1775-S4A, -B, or S5	PLC-3
1775-SR, -SR5	PLC-3/10
Integral	PLC-5/15, -5/25, -5/30 -5/40, -5/60, -5/80
5250-RS	PLC-5/250

### Environment

Operating Temperature

0 to 60° C (32 to 140° F)

Storage Temperature

-40 to 85° C (-40 to 185° F)

Humidity

5 to 95%, non-condensing

## RediPANEL 800EM/EP Module

### Electrical

Built-in Power Supply 90 to 264V AC, 47-63 Hz  
18 to 30V DC

### Input Current and Power Ratings

	32 Buttons	16 Buttons	On/Off
24V DC Input	4.2A, 100VA	2.5A, 60VA	All On
	0.21A, 25VA	0.15A, 15VA	All Off
120V AC Input	2.0A, 230VA	0.9A, 115VA	All On
	0.25A, 30VA	0.25A, 30VA	All Off

Lamps 24V DC, Catalog No. 800E-N157

LEDs 24 Volts, Catalog No. 800T-N157R (Red)  
-N157G (Green)  
-N157A (Amber)

Communications Connector Standard 3-prong female connector  
(supplied with each module as Part No. 22112-046-03)

UL File / Guide ①

CSA ①

Enclosures

Device	Type of Enclosure			
	Cold Rolled Steel Faceplate	Stainless Steel Faceplate	Metal Enclosure	Fiberglass Enclosure
800EP	4/12/13, IP66	4/4X/12/13, IP66	12/13, IP65	4/4X/12/13, IP66
800EM	4/12/13, IP66	4/12/13, IP66	12/13, IP65	4/12/13, IP66

### Configurations

16 Push Button Module 6 red, 6 green, 4 amber backlit buttons

32 Push Button Module 8 red, 8 green, 8 amber, 8 clear (white) backlit buttons

### Weight

#### Panel Mount

16 Button 16.0 lbs. (7.27 kg)

32 Button 18.8 lbs. (8.55 kg)

#### Fiberglass Enclosure

16 Button 16.3 lbs. (7.41 kg)

32 Button 21.2 lbs. (9.64 kg)

#### Steel Enclosure

16 Button 28.0 lbs. (12.73 kg)

32 Button 36.3 lbs. (16.5 kg)

① UL listing for Hazardous locations Class I, Division 2, Groups A, B, C, and D is pending for RediPANEL type 800EM and 800EP modules.

## RediPANEL 800EM/EP Module

### Communications

User Supplied Cable

I/O Cable, Catalog No. 1770-CD or  
Belden cable 9463 only

Baud Rates

57.6K, 115.2K, 230.4K

Maximum Distance

10,000 feet (3,000 meters) at 57.6K  
5,000 feet (1,500 meters) at 115.2K  
2,500 feet (750 meters) at 230.4K

Remote I/O Serial Data Link

Communicates with the Allen-Bradley PLC controllers  
using the following scanner modules:

Scanner	PLC
1771-SN	PLC-2/05, -2/15, -2/16, -2/17
	PLC-5/12
1747-SN	SLC-5/02 or 5/03
1772-SD2 (Rev. 3 or later)	PLC-2/30
1775-S4A, -B, or S5	PLC-3
1775-SR, -SR5	PLC-3/10
Integral	PLC-5/15, -5/25, -5/30, -5/40, -5/60, -5/80
5250-RS	PLC-5/250

### Environment

Operating Temperature

0 to 40° C (32 to 104° F)

Storage Temperature

-40 to 85° C (-40 to 185° F)

Humidity

5 to 95%, non-condensing

## RediPANEL 800EM/EP Module

### Weight

16 Push Button Fiberglass	16.3 lbs (7.39 kg)
32 Push Button Fiberglass	21.2 lbs (9.62kg)
16 Push Button Sheet Metal	28.0 lbs (12.7 kg)
32 Push Button Sheet Metal	36.3 lbs (16.47 kg)
16 Push Button Face Plate	16.0 lbs (7.26 kg)
32 Push Button Face Plate	18.8 lbs (8.53 kg)

### Communications

User Supplied Cable

I/O Cable, Catalog No. 1770-CD or Belden cable 9463 only

Baud Rates

57.6K, 115.2K, 230.4K

Maximum Distance

10,000 feet (3,000 meters) at 57.6K  
5,000 feet (1,500 meters) at 115.2K  
2,500 feet (750 meters) at 230.4K

Remote I/O Serial Data Link

Communicates with the Allen-Bradley PLC controllers using the following scanner modules:

Scanner	PLC
1771-SN	PLC-2/05, -2/15, -2/16, -2/17 PLC-5/12
1747-SN	SLC-5/02, 5/03
1772-SD2 (Rev. 3 or later)	PLC-2/30
1775-S4A, -B, or S5	PLC-3
1775-SR, -SR5	PLC-3/10
Integral	PLC-5/15, -5/25, -5/40, -5/60, -5/80
5250-RS	PLC-5/250

### Environment

Operating Temperature

0 to 40° C (32 to 104° F)

Storage Temperature

-40 to 85° C (-40 to 185° F)

Humidity

5 to 95%, non-condensing

## RediPANEL 800T/H Module

### Electrical

Built-in Power Supply 90 to 132 or 185 to 264 VAC  
Input Current and Power Ratings

	32 Buttons	16 Buttons	On/Off
120V AC Input	1.25A, 150VA	0.75A, 90VA	All On
	0.4A, 48VA	0.3A, 36VA	All Off

Lamps 6.3V AC, Catalog No. 800T-N65  
ANSI #755 or #1866  
Illuminated Selector Switches,  
6.3V AC, Catalog No. 800M-N15, ANSI #86

Lamps Push-to-Test Button,  
28V DC, Catalog No. 800M-N17, ANSI #85

LEDs 6.3 Volts, Catalog No. 800T-N77R (Red)  
-N77G (Green)  
-N77A (Amber)

Communications Connector Standard 3-prong female connector  
(supplied with each module as Part No. 22112-046-03)

UL File / Guide Non-hazardous Locations: E56639 / NMTR  
Hazardous Locations: E10314 /N01V ①

CSA Non-hazardous Locations: LR62923 ①  
Hazardous Locations: LR11924

### Mechanical

Enclosure  
800T NEMA Type 12/13  
800H NEMA Type 4/4X

Configurations  
16 Push Button Module Standard: 4 red, 8 green, 4 amber  
32 Push Button Module Standard: 8 red, 16 green, 8 amber

Fuses  
Logic Fuse 1.25A Type MDL; 1.5A Type GMC  
Central Fuse 2.0A Type MDL, 2.0A Type GMC

Replacement Illuminated Push Button  
800T Catalog No. 800T-PB16 D1Z3- 1 N.O. Contact  
800H Catalog No. 800H-PB16 D1Z3- 1 N.O. Contact

Weight (Approximate)  
16 Push Button Module 9 lbs. (4.1 kg)  
32 Push Button Module 28 lbs. (12.71 kg)  
45 lbs. (20.43 kg)

① Hazardous location RediPANELs approved for 120 VAC Class 1, Division 2, Group A, B, C, and D for 800T Series D or later and 800H Series B or later.

## RediPANEL 800T/H Module

### Communications

User Supplied Cable

I/O Cable, Catalog No. 1770-CD or  
Belden cable 9463 only

Baud Rates

57.6K, 115.2K

Maximum Distance

10,000 feet (3,000 meters) at 57.6K  
5,000 feet (1,500 meters) at 115.2K

### Environment

Operating Temperature

800H

0 to 40° C (32 to 104° F)

800T

0 to 60° C (32 to 140° F)

Storage Temperature

-40 to 85° C (-40 to 185° F)

Humidity

5 to 95%, non-condensing

## Custom RediPANEL Modules

### Custom 800A RediPANEL Module

The 800A RediPanel Module is available in a standard or custom configuration. If the standard unit with momentary push buttons does not meet your application requirements you can create a custom module.

Custom modules can contain any of the following:

- Momentary illuminated push buttons
- Maintained illuminated push buttons
- 2 position selector switches
- Flush head or extended head operators
- 2 position key switches

Custom units are factory ordered or customer installed. The Modification/Replacement Kit allows you to modify a standard module in the field. The kit contains:

- 3 templates (one for each module configuration)
- 800A mounting wrench
- instructions

#### Bulletin 2705 Push Button Modification / Replacement Kit

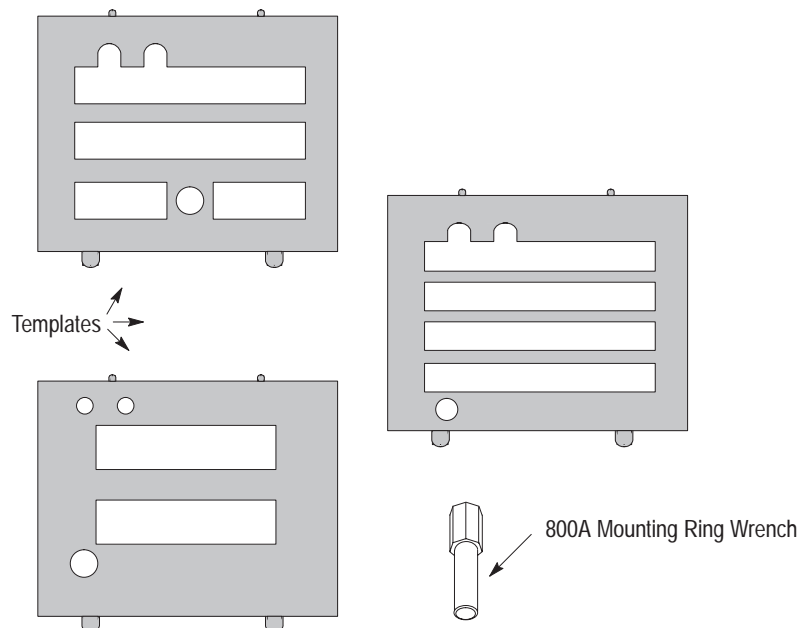



## Custom 800EM/EP RediPANEL Modules

The Bulletin 800E selector switches described below can be installed in RediPANELs:

### Two Position Illuminated

These devices operate the same as a normal pushbutton. All wiring cable terminals are used.

### Two Position Non-Illuminated

The switch terminals wires (blue and grey) make normal connections. The lamp wires are not used and must be insulated to protect them from touching any other conductive material. The wire terminal should be insulated with heat shrink tubing or tape and secured to the cable assembly with a tie wrap.

### Three Position Non-Illuminated

This assembly requires that one of the adjacent positions not contain a push button but either be left blank or contain a pilot lamp. Two terminal blocks (800E-4X10V) are required. The gray wire from the adjacent terminal block must be moved to the second terminal block on the three position selector switch assembly. It may be necessary to cut the tie wrap to allow the wires to reach the terminal block. If the adjacent position is blank, the blue wire that would have been used for the lamp must be moved to the second terminal block connector. If the blue wire is not long enough, a wire jumper (2705-E3) must be installed from the second contact block to the first contact block terminal screw. If the adjacent position contains a pilot lamp, the existing wires stay as is in the adjacent position. The lamp wires and adjacent contact block wires not used must be insulated to protect them from touching any other conductive material. The wire terminal should be insulated with heat shrink tubing or tape and secured to the cable assembly with a tie wrap.

When the switch is actuated left, the normal input image table bit will be set. When the switch is actuated right, the adjacent location that was used will be set.

### Three Position Illuminated

This assembly requires that one of the adjacent positions not contain a push button but either be left blank or contain a pilot lamp. Two terminal blocks (800E-4X10V) are required. The gray wire from the adjacent terminal block must be moved to the second terminal block on the three position selector switch assembly. It may be necessary to cut the tie wrap to allow the wires to reach the terminal block. If the adjacent position is blank, the blue wire that would have been used for the lamp must be moved to the second terminal block connector. If the blue wire is not long enough, a wire jumper

(2705-E3) must be installed from the second contact block to the first contact block terminal screw. If the adjacent position contains a pilot lamp, the existing wires stay as is in the adjacent position. The lamp wires and adjacent contact block wires not used must be insulated to protect them from touching any other conductive material. The wire terminal should be insulated with heat shrink tubing or tape and secured to the cable assembly with a tie wrap.

When the switch is actuated left, the normal input image table bit will be set. When the switch is actuated right, the adjacent location that was used will be set. If the normal output image table bit is set, the selector switch lamp will illuminate. If the adjacent output image table bit is set, the adjacent pilot lamp will illuminate.

### **Pilot Lamp Only**

A pilot lamp only may be installed in any position. The blue and yellow wires from the cable assembly will connect to the lamp terminals in the normal fashion.

The switch terminals wires (blue and grey) are not used and must be insulated to protect them from touching any other conductive material. The wire terminal should be insulated with heat shrink tubing or tape and secured to the cable assembly with a tie wrap.

## Custom 800T/H RediPANEL Modules

The 800T/H Push Button Modules can contain any combination of the following 800T or 800H devices:

- Momentary push buttons, illuminated/non-illuminated
- Push/Pull push buttons, illuminated/non-illuminated
- Flush head, extended head or mushroom head operators
- Pilot lights
- 2 position selector switches, illuminated/non-illuminated
- 3 position selector switches, illuminated/non-illuminated
- 4 position selector switches, non-illuminated

Pilot lights must be either a 120V AC transformer or 120V AC transformer LED. Push-to-Test lights are not acceptable.

Custom modules are factory ordered or customer installed. To order a custom unit from the factory, complete a custom order worksheet as described in Publication 2705-3.3

To modify a standard module in the field, the following 800T/H accessories are available.

800T/H Accessories	Catalog No.
Pre-Assembled Push Button and Adapter Kit (enter "Z3" as the last 2 digits of selected push button Catalog Numbers).	800H-_____Z3 or 800T-_____Z3
2 position devices using a single shallow contact block. Exception: Devices using the 800T-XD2 contact block (1 N.C.) or the 800T-XD4 contact block (1 N.C. Late Break)	800T-N305
All 3 position devices	800T-N306
2 position devices that use the 800T-XD2	800T-N307
4 position Selector Switch	800T-N308
Pilot Light Adapter Cable For 3 or 4 position devices. Allows additional pilot light.	800T-N309

## 800A Switch Replacement Kit and LED Upgrade Kit

### Overview

This appendix contains information for the replacement of push button devices on 8, 16, and 32 Push Button Modules. Information is also provided for the LED lamp upgrade kit.

### Replacement Kit

The replacement kit includes templates for each module plus an 800A-N50 mounting ring wrench.

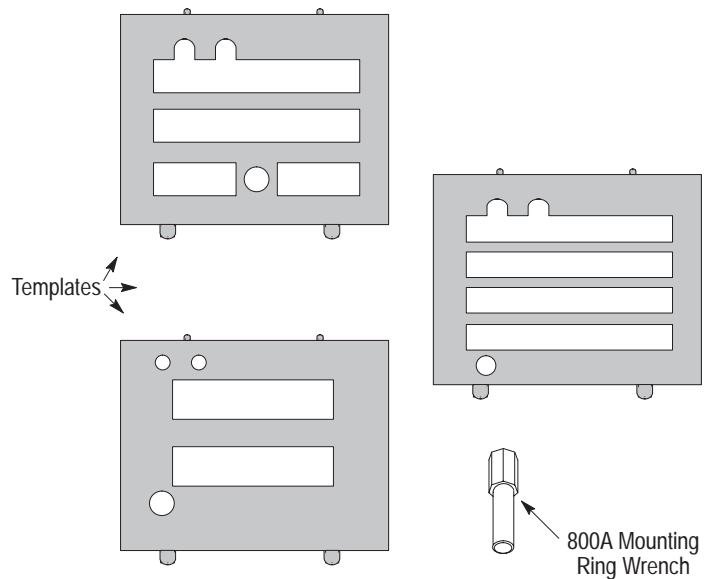

**ATTENTION:** Disconnect power to the module.

If the module is mounted in an enclosure, remove it and use the following instructions:

## Appendix C

### 800A Switch Replacement Kit LED Upgrade Kit

1. Place the Push Button Module on a flat surface and locate the 4 screws connecting the push button faceplate to the sheet metal housing.

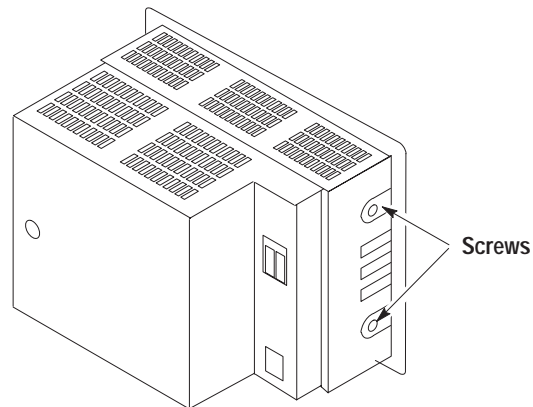

2. Remove the screws and **carefully** slide the faceplate out of the housing.

**Note:** You will be able to slide the faceplate out approximately 1 inch (25 mm).

3. Unplug the ribbon cable(s) on the faceplate from the push button printed circuit (PC)board. **Note:** 8 and 16 Push Button Modules have 1 ribbon cable and 32 Push Button Modules have 2 ribbon cables.

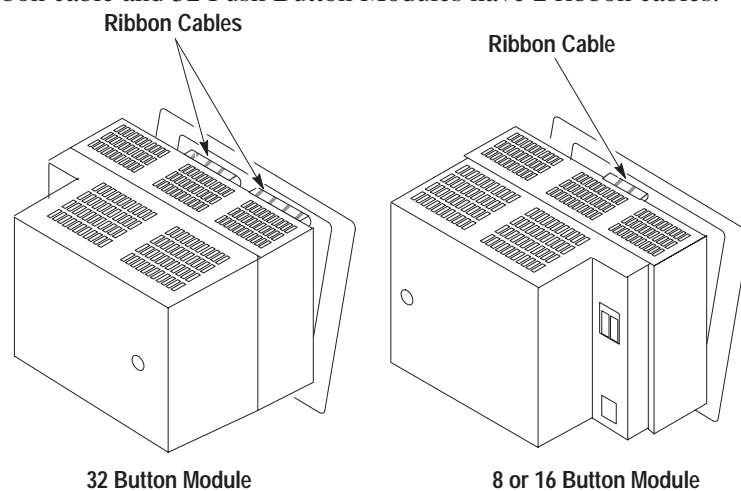

4. A 2-wire assembly is also connected to the PC board. Disconnect the connector plug for this 2 wire assembly.
5. Select the correct template for the Push Button Module (8, 16, or 32 button) you are modifying. Place the Push Button Module face down on the template.

6. Remove the screws that secure the PC board to the push buttons.
7. Carefully remove the PC board from the push buttons by gently prying at each corner of the board.

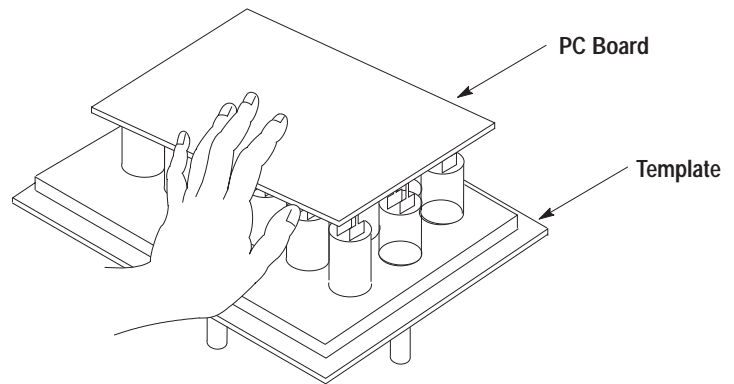

**ATTENTION:** Do not bend any pins on the push buttons.

8. Remove the brass colored retaining ring with the 800A-N50 mounting ring wrench.

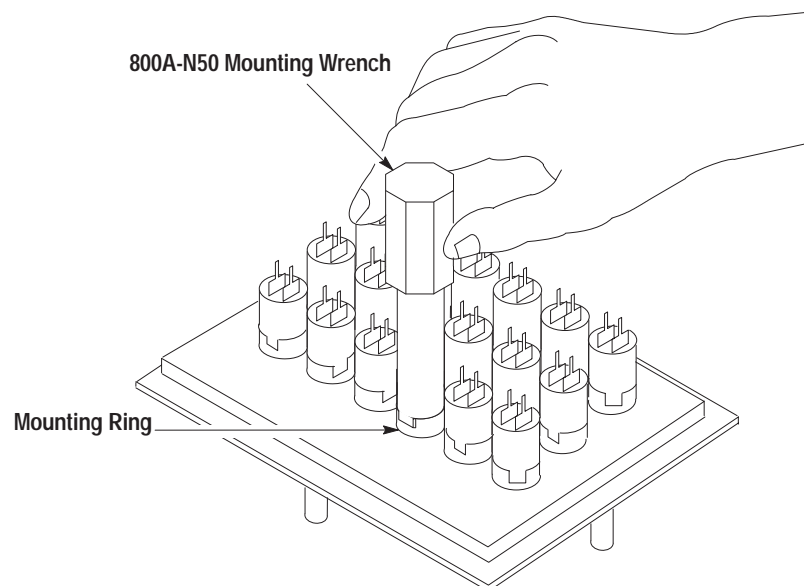

9. To access both the front and back of the push button, set the template on end. The push button can be removed from the front.

10. A replacement device can be inserted from the front. **Note:** Make sure new switch is lined up in template before securing the retaining ring.
11. Place faceplate and template face down on a flat surface. Replace the retaining ring and torque to 12 in-lbs.

**Note:** Examine for bent pins and check for alignment problems.

12. Starting at one of the corners, carefully align PC board sockets over pins. Check at eye level to verify that pins and sockets line up. Make the appropriate adjustments if necessary.
13. Carefully apply downward pressure to fully insert pins in sockets.
14. Examine pins to make sure all are fully inserted into the sockets.
15. Replace the four screws that secure the PC board to the push buttons. Torque to 9 in-lbs.
16. Plug in the ribbon cables and reconnect wiring. Make sure all connections are seated properly.
17. Slide the push button assembly into the sheet metal housing.
18. Replace the 4 screws that secure the faceplate to the housing. Torque to 18 in-lbs.

**To Verify Operation of Modified Push Button Module:**

Apply power and proceed through the Push-to-Test sequence. See Chapter 5.

## LED Lamp Upgrade

To upgrade from the incandescent lamps to the LED lamp, order a lamp upgrade kit:

- For 32 operator modules, order Catalog No. 2705-NLU1
- For 16 operator modules, order Catalog No. 2705-NLU2
- For 8 operator modules, order Catalog No. 2705-NLU3

Replace the existing circuit board with the board provided in the kit (instructions included with the kit). LEDs must be purchased separately:

- For 12 VDC Red LEDs, order Catalog No. 800T-N61R
- For 12 VDC Green LEDs, order Catalog No. 800T-N61G
- For 12 VDC Amber LEDs, order Catalog No. 800T-N61A



## Adding/Replacing Push Button Legends

This appendix describes how to add or replace push button legends for 800A push button modules.



**ATTENTION:** To avoid electrical shock or unintended operation of the equipment, disconnect power before servicing.

1. Remove the lens carrier from the push button on the module by gently prying it out on either side of the carrier with a screwdriver.



**ATTENTION:** Do not use the slot on either side of the lens carrier for prying. This may break the assembly.

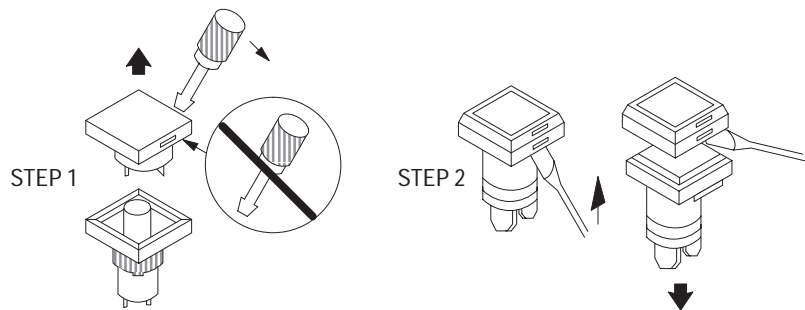

2. Remove the color lens by placing a small screwdriver into the slot on the back of the lens carrier and gently prying the 2 pieces apart.



**ATTENTION:** Do not use too much pressure when prying the assembly apart. This may damage the colored lens.

3. Insert the new legend and snap the 2 pieces back together.
4. Replace the keyed lens carrier into the push button.
5. Check for proper operation of the push button.

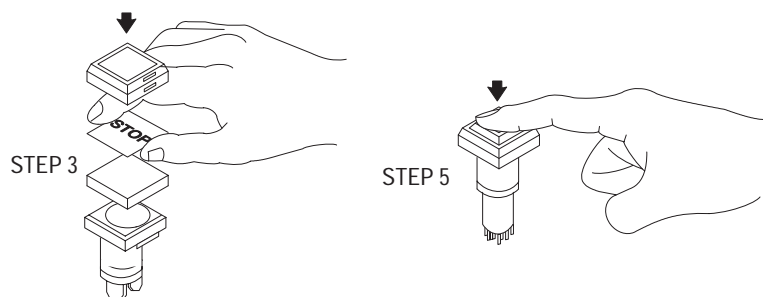

## Replacing Lamps

This appendix shows how to replace lamps in 800A Push Button Modules.



**ATTENTION:** To avoid electrical shock or unintended operation of the equipment, disconnect power before servicing.

If you replace bulbs on a regular basis, it is recommended that you replace the entire set.

1. Remove the lens carrier from the push button on the module by gently prying it out on either side of the carrier with a screwdriver.



**ATTENTION:** DO NOT use the slot on either side of the lens carrier for prying as it may break the assembly.

2. Remove existing lamp from socket.



**ATTENTION:** DO NOT use the screwdriver or any other metal object to remove the bulb. Use ONLY the 800M-N5 lamp replacement tool.

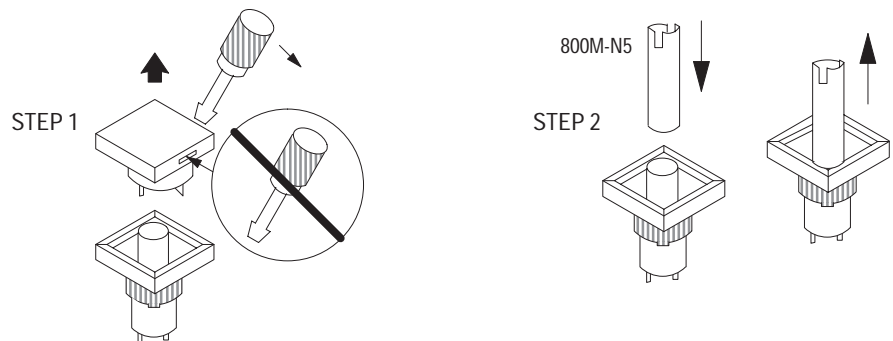

3. Carefully insert the new lamp into the socket.



**ATTENTION:** Before replacing the lens carrier into the push button, **be sure** the lamp is seated properly or a short may result. If installing an LED, the LED must be installed with plus (+) indicator facing to the left.

---

4. Replace the keyed lens carrier into the push button.
5. Check for proper operation of the push button.

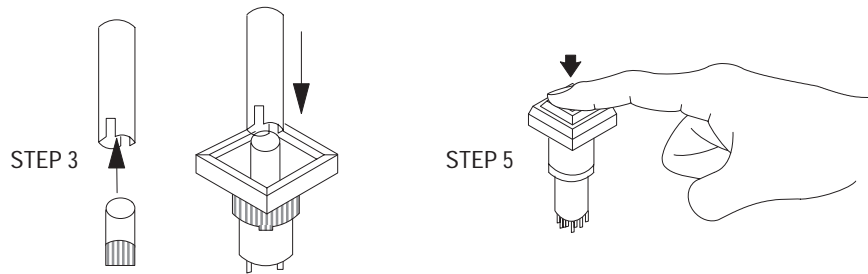

## Converting from Incandescent to LED Lamps

### LED Lamp Upgrade

This appendix describes how to convert the RediPANEL modules from incandescent to LED illumination.

To replace the incandescent bulb with an LED lamp for an 800A RediPANEL module, order the lamp upgrade kit.

For this module:	Order:
32 Operator Modules	Catalog No. 2705-NLU1
16 Operator Modules	Catalog No. 2705-NLU2
8 Operator Modules	Catalog No. 2705-NLU3

Replace the existing circuit board with the board provided in the kit. Instructions are provided with the kit.

You must purchase the LEDs separately.

For these LEDs:	Order:
12 VDC Red LEDs	Catalog No. 800T-N61R
12 VDC Green LEDs	Catalog No. 800T-N61G
12 VDC Amber LEDs	Catalog No. 800T-N61A

To convert an 800T/H RediPANEL from incandescent bulbs to LED lamps, you must have a 120 VAC transformer style power module. Order as follows:

For these LEDs:	Order:
Red LEDs	Catalog No. 800T-N318R
Green LEDs	Catalog No. 800T-N318G
Amber LEDs	Catalog No. 800T-N318A

## Installing/Replacing Push Buttons

This appendix shows how to install or replace push buttons in RediPANEL modules.

### Installing or Replacing 800T/H Push Buttons



**ATTENTION:** To avoid electrical shock or unintended operation of the equipment, disconnect power before servicing.

1. Open enclosure by loosening the screws on the back of RediPANEL module. Guide the modules back door open.
2. Disconnect RediPANEL wiring from the push button you want to replace.
3. Remove the push button from the enclosure.
4. Mount the replacement push button in the enclosure.
5. Attach RediPANEL wiring to the replacement push button. See Push Button and Selector Switch Connection Examples on next page.
6. Carefully guide the modules back door closed. Be sure that the wiring is not pinched between the side plate and the chassis. Tighten the screws on the back of the RediPANEL enclosure.

Figure G.1  
Replacing 800T/H Push Buttons



## Push Button and Selector Switch Connection Examples

### Illuminated Push Button (800T-P B 1 6 R Z3)

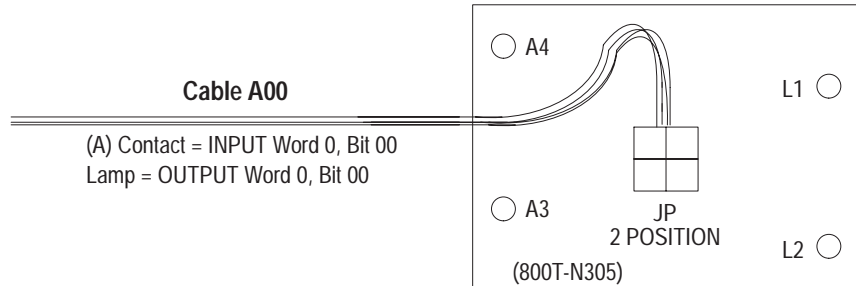

### Illuminated 3 Position Selector Switch (800T-1 6 J R 2 K B 7 A X Z3)

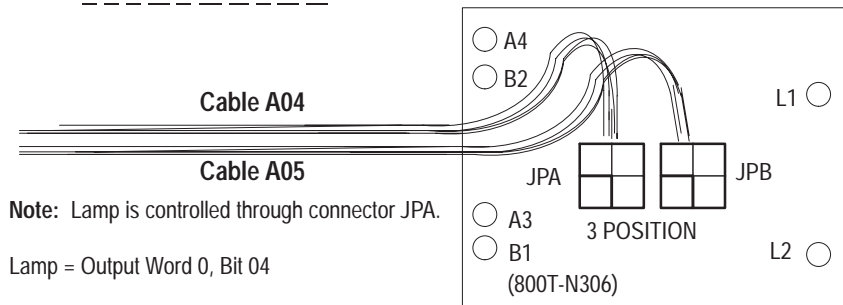

Contact				Bit Location
A	X	0	0	INPUT Word 0, Bit 04
B	0	0	X	INPUT Word 0, Bit 05

0 = Open; X = Closed

### Non-Illuminated 4 Position Selector Switch (800T-N 2 K K 4 8 Z3)

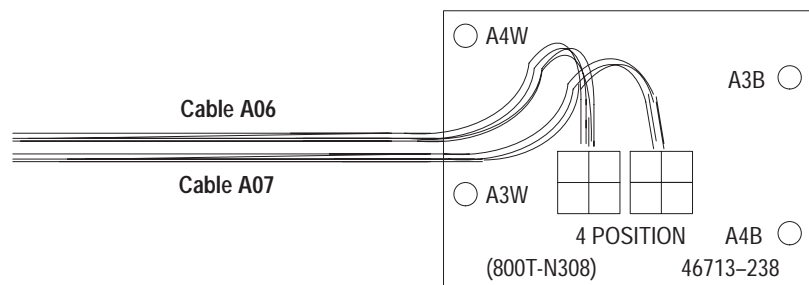

(A) Contact					Bit Location
White Actuator	0	0	X	X	INPUT Word 0, Bit 06
Black Actuator	X	0	0	X	INPUT Word 0, Bit 07

0 = Open; X = Closed

## Attaching the 800T Adaptor Kit to 800T/H Push Buttons.

### To attach the 800T Adaptor Kit to an 800T/H Push Buttons:

1. Remove the wiring screws from the contact block and transformer on the 800T/H push button.
2. Insert circuit board posts into the appropriate wiring screw holes on the push button contact block and transformer.
3. Put spacers in position and line-up caps on circuit board with circuit board posts.
4. Press circuit board down so it is firmly seated on circuit board posts.
5. Secure the circuit board to the push button with enclosed screws.

### Attaching the 800T Adapter Kit to an 800T/H Push Button

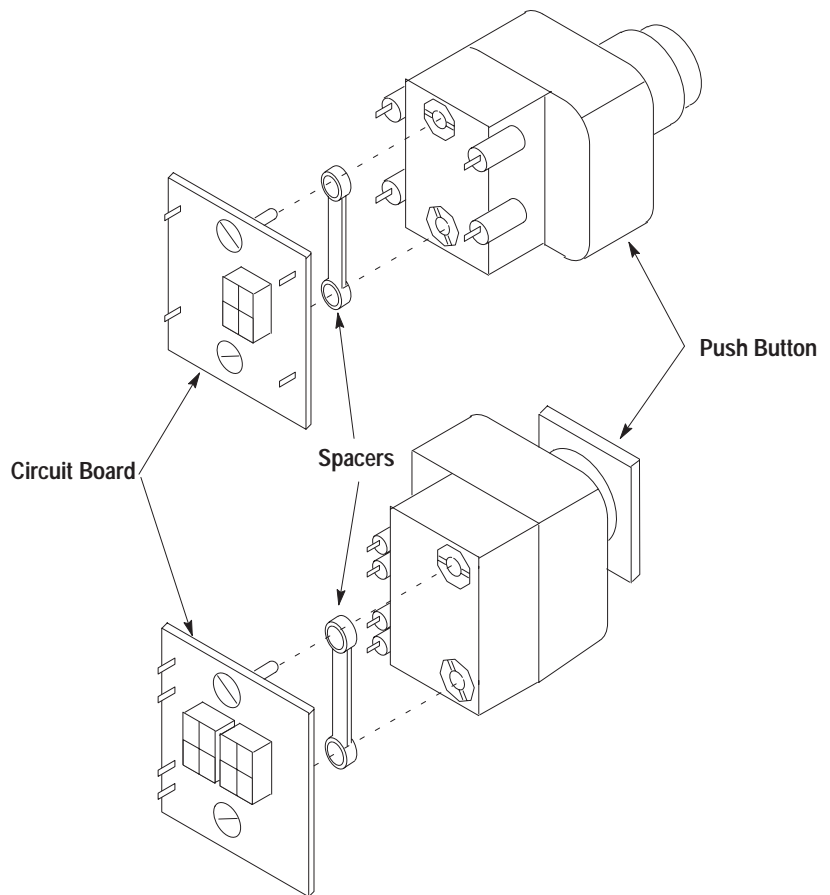

## Installing/Replacing 800EP/EM Push Buttons

### To install or replace 800EP/EM Push Buttons:

1. Without removing the wiring from the contact block, remove the latch with a screw driver.
2. Remove the locking ring on the back of the operator.
3. Remove the operator by pulling it out from the front of the panel.
4. Install the new operator by inserting it into the panel from the front and attaching the locking ring. Torque EP (plastic) mounting ring with drive wrench 800E-AW2 to 15 lb-in. Torque EM (metal) mounting ring with 24 mm socket to 40 lb-in.
5. Snap the latch back onto the operator.

### Typical Connection Diagram

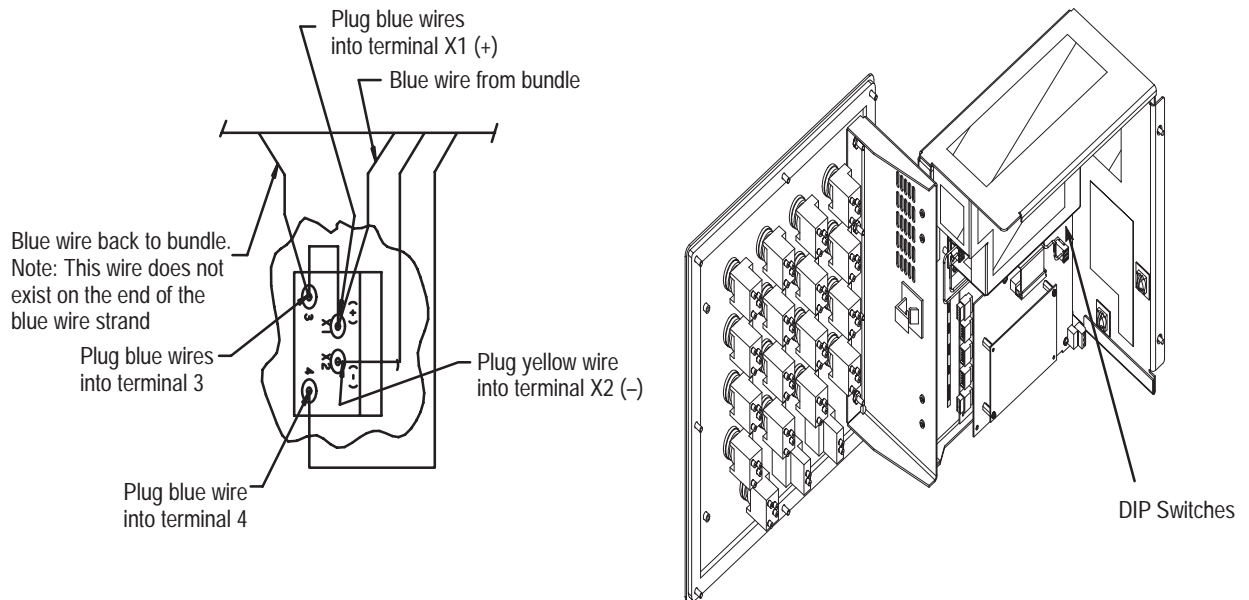



## Installing Color Inserts in Membrane Modules

You can install color legend inserts in the NEMA Type 4X Modules. The following legend kits are available.

Catalog Number	Legend Kit Includes:
2705-N3	2 sheets of white inserts 2 sheets of 4 color inserts
2705-N3W	1 sheet of white inserts
2705-N3R	8 strips (equivalent to 1 sheet) of red legends
2705-N3G	8 strips (equivalent to 1 sheet) of green legends
2705-N3B	8 strips (equivalent to 1 sheet) of blue legends
2705-N3Y	8 strips (equivalent to 1 sheet) of yellow legends

### To install color inserts in the NEMA Type 4X module:

1. Remove the 4 screws that secure the back faceplate to the housing.
2. Pull the faceplate away from housing (approximately 2-inch clearance).
3. Slide the inserts in the appropriate row of buttons.
4. Replace the 4 screws that secure the back faceplate to the housing.

### Installing Color Legend Inserts

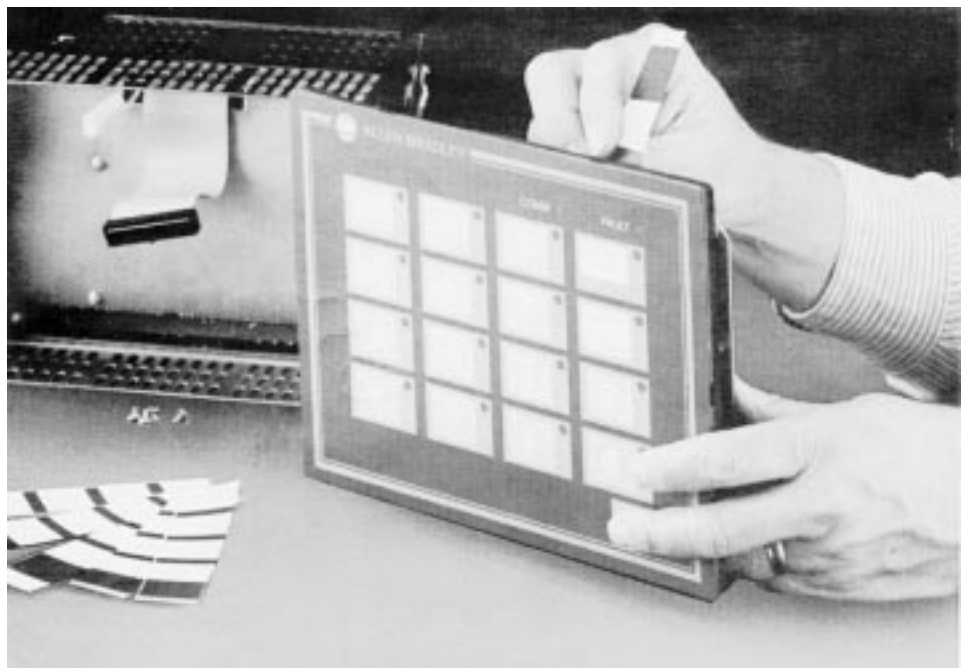

## A

Address Conversion, 4-27

## B

Back Panel Removal, 800T/H Modules, 5-5

Baud Rate, 2-6 to 2-7

Bit Addresses

16 button module, 4-2

addressing example, 4-2 to 4-4

32 button module, 4-5 to 4-7

addressing example, 4-8

8 button module, 4-1

addressing example, 4-1

Block Transfer, PLC-2, 4-12

## C

Color Inserts, installing in membrane modules, H-1

COMM Indicator, 5-3

Connection Examples, Push Button & Selector Switch, G-2

Custom Configurations

800A modules, 1-2, B-1

800EM/EP modules, 1-3

800T/H modules, 1-4, B-2, B-4

## D

DIP Switches, 2-3

switch bank 1, 2-4

switch bank 2, 2-6

## E

Electrical Noise, avoiding, 5-1

Electrical Precautions, 3-1

Enclosures, 3-3

spacing of 800A modules, 3-4

spacing of 800EM/EP modules, 3-5 to 3-6

spacing of 800T/H modules, 3-7

## F

Fault Indicator, 5-2

Files

G, 4-25

scanner input, 4-26

Flashing Lamps, 2-1, 2-6 to 2-7, 4-23

## G

G File, 4-25

Grounding, 3-1

## H

Handshaking, 2-1, 2-6 to 2-7, 4-21

timing diagrams, 4-22

## I

I/O Image Tables

16 button modules, 2-9 to 2-10

32 button modules, 2-11

8 button modules, 2-8

Indicators

COMM indicator, 5-3

fault, 5-2

Input/output size, 2-1

Installation

800A and sealed membrane modules, 3-8 to 3-9

800EM/EP modules, 3-10 to 3-13

800T/H modules, 3-14 to 3-15

connecting power, 3-2

connecting to remote I/O link, 3-16

connecting to scanner module, 3-16

electrical precautions, 3-1

enclosures, 3-3

grounding, 3-1

modules, 3-8 to 3-15

power requirements, 3-2

remote I/O cables, 3-16

Installing color inserts in membrane modules, 3-8 to 3-9

## L

Lamps

LED testing, 5-4

replacing 800A buttons, E-1 to E-2

Last Rack, 2-6 to 2-7

Last State, 2-6 to 2-7

LED Lamps

converting from incandescent, F-1

upgrade kit, C-5

Legends, D-1

**M**

Maintenance, 5-1  
Module Bit Addresses, 4-1

**O**

Operating Cycles, 4-19

**P**

PLC-2 with a 1772-SD2 Scanner, 4-9  
  program example, 4-9 to 4-10  
PLC-2 with a Sub I/O Scanner, 4-11  
  block transfer example, 4-11 to 4-12  
  remote addressing, 4-13  
PLC-5, 4-14  
  programming example, 4-14  
PLC-5 with a Sub I/O Scanner, 4-15  
  block transfer example, 4-15 to 4-16  
  programming example, 4-17 to 4-18  
Power requirements, 3-2  
Preventive Maintenance, 5-1  
Push Button Contact Test, 5-4  
Push Buttons  
  adding/replacing legends, D-1  
  and selector switch connection example, G-2  
  attaching adaptor kit to 800T/H buttons, G-3  
  installing/replacing 800EP/EM buttons, G-4  
  installing/replacing 800T/H buttons, G-1  
Push-to-Test Button, 5-4

**R**

Rack size, 2-1 to 2-2, 2-6 to 2-7  
RediPanel Push Button Modules  
  800A devices, 1-2  
  800EP/EM devices, 1-2  
  800T/H devices, 1-4  
  description, 1-1  
  NEMA type 4X membrane, 1-5  
Remote I/O Link, 3-16  
Replacement Kit, 800A Switch, C-1 to C-4  
Response Time, 4-20

**S**

Scanner Input File, 4-26  
Scanner Module Connection, 3-16  
SLC, programming example, 4-24 to 4-27  
Space and clearance requirements  
  800A modules, 3-4  
  800EP/EM modules, 3-5 to 3-6  
  800T/H modules, 3-7  
Specifications  
  800A module, A-1 to A-2  
  800EM/EP module, A-3 to A-5  
  800T/H module, A-6 to A-7  
Switch Bank 1  
  I/O group, 2-4  
  rack address, 2-4 to 2-5  
Switch Bank 2  
  baud rate, 2-6  
  flashing lamps, 2-6  
  functions, 2-7  
  handshake, 2-6  
  last rack, 2-6  
  last state, 2-6  
  rack size, 2-6  
  settings, 2-6  
  steady lamps, 2-6  
  switch fault mode, 2-6  
Switch Fault Mode, 2-6 to 2-7  
Switch Replacement Kit, C-1 to C-4

**T**

Troubleshooting  
  COMM indicator, 5-3  
  fault indicator, 5-2  
  push-to-test button, 5-4  
  questions, 5-6

**U**

Unpopulated Configurations  
  800EP/EM modules, 1-3  
  800T/H modules, 1-5  
Upgrade, LED Lamp, F-1



Rockwell Automation helps its customers receive a superior return on their investment by bringing together leading brands in industrial automation, creating a broad spectrum of easy-to-integrate products. These are supported by local technical resources available worldwide, a global network of system solutions providers, and the advanced technology resources of Rockwell.



## Worldwide representation.

Argentina • Australia • Austria • Bahrain • Belgium • Bolivia • Brazil • Bulgaria • Canada • Chile • China, People's Republic of • Colombia • Costa Rica • Croatia • Cyprus • Czech Republic • Denmark • Dominican Republic • Ecuador • Egypt • El Salvador • Finland • France • Germany • Ghana • Greece • Guatemala • Honduras • Hong Kong • Hungary • Iceland • India • Indonesia • Iran • Ireland • Israel • Italy • Jamaica • Japan • Jordan • Korea • Kuwait • Lebanon • Macau • Malaysia • Malta • Mexico • Morocco • The Netherlands • New Zealand • Nigeria • Norway • Oman • Pakistan • Panama • Peru • Philippines • Poland • Portugal • Puerto Rico • Qatar • Romania • Russia • Saudi Arabia • Singapore • Slovakia • Slovenia • South Africa, Republic of • Spain • Sweden • Switzerland • Taiwan • Thailand • Trinidad • Tunisia • Turkey • United Arab Emirates • United Kingdom • United States • Uruguay • Venezuela

Rockwell Automation Headquarters, 1201 South Second Street, Milwaukee, WI 53204-2496 USA, Tel: (1) 414 382-2000 Fax: (1) 414 382-4444

Rockwell Automation European Headquarters, Avenue Hermann Debroux, 46, 1160 Brussels, Belgium, Tel: (32) 2 663 06 00, Fax: (32) 2 663 06 40

Rockwell Automation Asia Pacific Headquarters, 27/F Citicorp Centre, 18 Whitfield Road, Causeway Bay, Hong Kong, Tel: (852) 2887 4788, Fax: (852) 2508 1846

World Wide Web: <http://www.ab.com>