



Installation Instructions for Shunt Trip for Cutler-Hammer EHD, FDB, FD, HFD, FDC, FW, HFW, FWC Circuit Breakers, Molded Case Switches, and F-Frame Motor Circuit Protectors (HMCP)



WARNING

DO NOT ATTEMPT TO INSTALL OR PERFORM MAINTENANCE ON EQUIPMENT WHILE IT IS ENERGIZED. DEATH, SEVERE PERSONAL INJURY, OR SUBSTANTIAL PROPERTY DAMAGE CAN RESULT FROM CONTACT WITH ENERGIZED EQUIPMENT. ALWAYS VERIFY THAT NO VOLTAGE IS PRESENT BEFORE PROCEEDING WITH THE TASK, AND ALWAYS FOLLOW GENERALLY ACCEPTED SAFETY PROCEDURES.

CUTLER-HAMMER IS NOT LIABLE FOR THE MISAPPLICATION OR MISINSTALLATION OF ITS PRODUCTS.

The user is cautioned to observe all recommendations, warnings, and cautions relating to the safety of personnel and equipment, as well as all general and local health and safety laws, codes, and procedures.

The recommendations and information contained herein are based on Cutler-Hammer experience and judgement, but should not be considered to be all-inclusive or covering every application or circumstance which may arise. If any questions arise, contact Cutler-Hammer for further information or instructions.

1. INTRODUCTION

General Information

The shunt trip (Fig. 1-1) provides remote controlled electrical tripping for the circuit breaker and consists of an intermittent rated solenoid with a tripping plunger and a cutoff switch mounted in a plug-in module. Shunt trip modules are mounted so that when the solenoid plunger retracts into the energized solenoid, the trip lever presses against the trip bar and trips the circuit breaker. As the circuit breaker trips, the accessory operating projection on the molded crossbar presses against the cutoff switch actuator arm to open the cutoff switch, disconnecting power to the solenoid and preventing coil burn out.

Table 1-1 lists application and electrical operating rating data for the shunt trip.

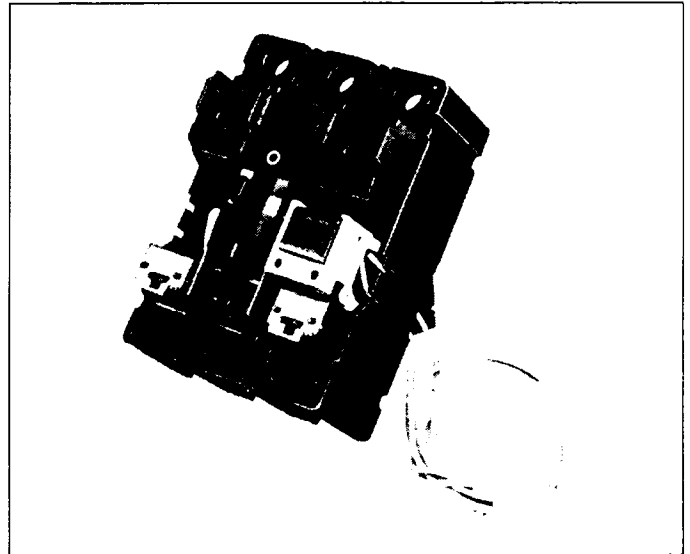

Fig. 1-1. Shunt Trip Installed in F-Frame Circuit Breaker

Depending on the model ordered, connections for the shunt trip are in one of four forms. The standard wiring configuration is pigtail leads exiting the rear of the base directly behind the shunt trip. Optional configurations include a terminal block mounted on the same side of the base as the accessory, leads exiting the side of the base where the accessory is mounted, and leads exiting the rear of the base on the side opposite the accessory. The 18-inch long pigtail leads are color coded for identification; identification labels are provided for pigtail leads and terminal block points. For allowable locations of all accessories, refer to Selection Data 29-120F.

Note: No more than three pigtail leads can be routed through the rear trough in the circuit breaker base. When the walking beam interlock is used with the circuit breaker, the rear trough cannot be used for accessory pigtail leads.

This instruction leaflet (IL) gives detailed procedures for installing the shunt trip.

2. INSTALLATION

Note: For sealed circuit breakers, Underwriters Laboratories, Inc. UL489 requires that internal accessories be installed at the factory. The shunt trip is listed only for factory installation under UL File E7819.

Where local codes and standards permit and UL listing is not required, internal accessories can be field installed.

Before attempting to install the shunt trip, check that the catalog number is correct and the rating of the accessory satisfies job requirements.

The shunt trip is shown in kit form in Fig. 2-1 and can be supplied as either a right- or left-hand assembly. Depending on the catalog number ordered, the shunt trip can be installed in the right accessory mounting cavity of a 2-pole circuit breaker, in the left or right cavity of a 3-pole circuit breaker, or in the left or neutral cavity of a 4-pole circuit breaker. A shunt trip must be installed in the circuit breaker before the circuit breaker is mounted in an electrical system. To install the shunt trip, perform the following procedures:

Note: A circuit breaker that is mounted in an electrical system must be removed to install the accessory. To ensure correct accessory installation, the circuit breaker must be placed on a horizontal surface.

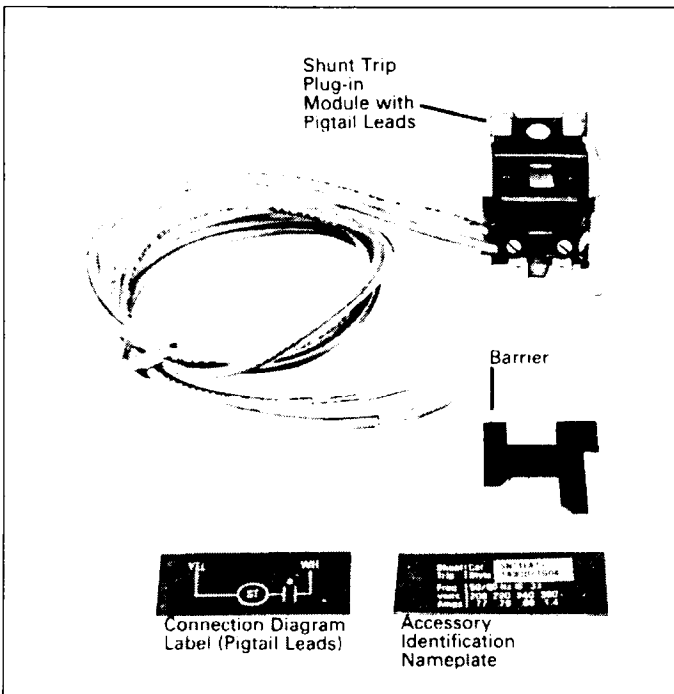

Fig. 2-1. Shunt Trip Kit



WARNING

BEFORE REMOVING A CIRCUIT BREAKER INSTALLED IN AN ELECTRICAL SYSTEM, MAKE SURE THE CIRCUIT BREAKER IS SWITCHED TO THE OFF POSITION AND THERE IS NO VOLTAGE PRESENT WHERE WORK IS TO BE PERFORMED. SPECIAL ATTENTION SHOULD BE PAID TO REVERSE FEED APPLICATIONS TO ENSURE NO VOLTAGE IS PRESENT. THE VOLTAGES IN ENERGIZED EQUIPMENT CAN CAUSE DEATH OR SEVERE PERSONAL INJURY.

- 2-1. Switch circuit breaker to the OFF position.
- 2-2. Disconnect and remove circuit breaker from installation and terminal connections.
- 2-3. Remove eight cover screws and cover. The handle must be in the OFF position if the circuit breaker has a cover interlock.



CAUTION

DURING INSTALLATION AND MECHANICAL CHECKS OF THE SHUNT TRIP, DO NOT TOUCH THE CIRCUIT BREAKER OR MCP CALIBRATED TRIP MECHANISM. CONTACT WITH THE CALIBRATED TRIP MECHANISM COULD CHANGE TRIP CHARACTERISTICS.

Note: For a shunt trip having rear or opposite-side exiting pigtail leads, thread leads through trough in side of base before attempting to install the accessory. Pigtail leads exiting in this manner must be eased through trough as the shunt trip is inserted into mounting cavity.

- 2-4. Reset the circuit breaker if tripped and switch the breaker ON.
- 2-5. Route wiring to meet installation requirements (see Fig. 2-2).
- 2-6. Insert shunt trip as described in the following steps (see Fig. 2-3):

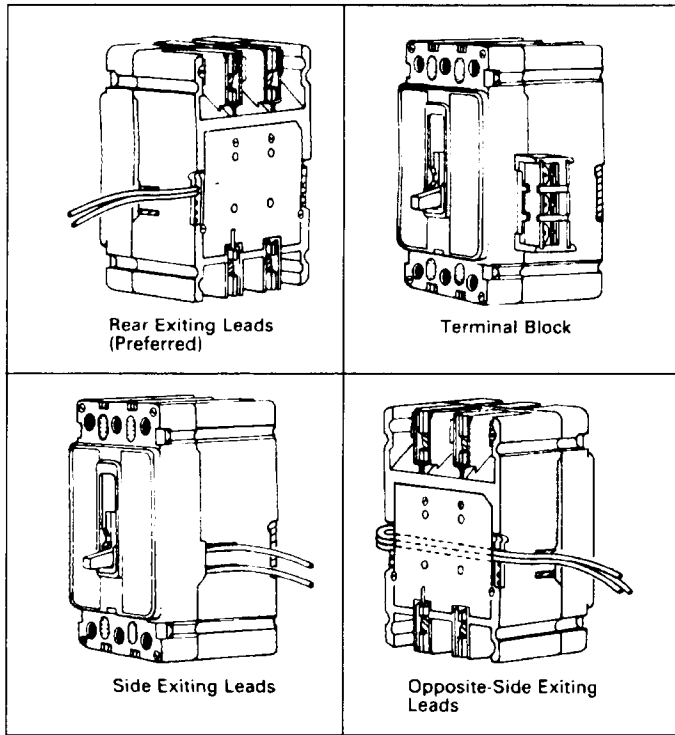

Fig. 2-2. Accessory Wiring Options

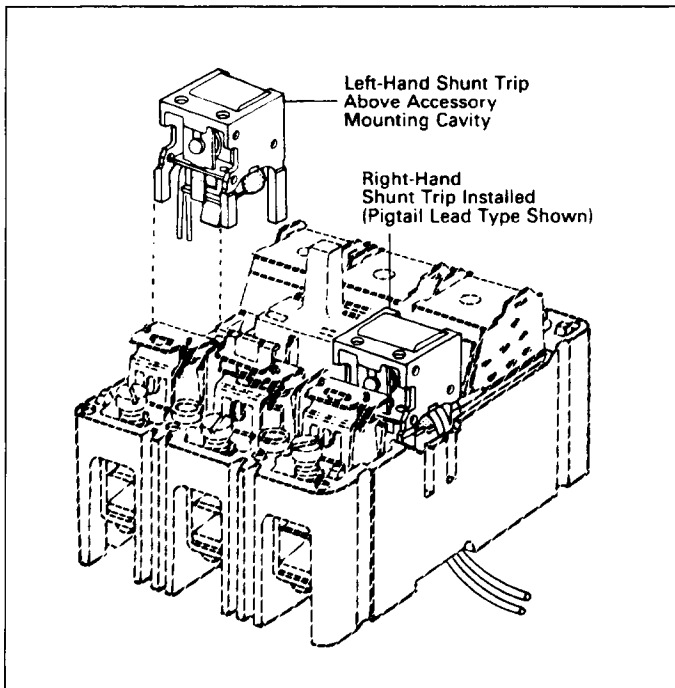

Fig. 2-3. Shunt Trip Installation Positions

- a. Slide barrier into position between molded crossbar and trip bar. Long leg of barrier must go into slot in base (see Fig. 2-4).
- b. Slide shunt trip plug-in module into mounting slots in circuit breaker base.

Note: The circuit breaker must be in the ON position while inserting the shunt trip.

- c. End of actuator arm should be between crossbar and trip bar (see Fig. 2-5). For terminal block assemblies, slide terminal block into mounting slot in side of base as plug-in module is being positioned.
- d. If required, complete routing of opposite-side exiting leads.



WARNING

WHEN CHECKING THE ACCESSORY, DO NOT PUT FINGERS NEAR MOVING PARTS INSIDE THE CIRCUIT BREAKER CASE. SPRINGS CAUSE INTERNAL PARTS TO MOVE QUICKLY AND WITH FORCE. CONTACT WITH MOVING PARTS CAN CAUSE INJURY.

2-7. Perform a mechanical check of the shunt trip after installation:

- a. With the circuit breaker still electrically isolated, hold shunt trip plug-in module in position and reset the circuit breaker.
- b. Hold accessory in position. Using a small flat-blade screwdriver, push in on solenoid plunger (see Fig. 2-6). Circuit breaker should move to the trip position.
- c. If mechanical check does not trip the circuit breaker, confirm that the shunt trip is correctly installed. If the shunt trip appears to be correctly installed and the problem persists, contact Cutler-Hammer.

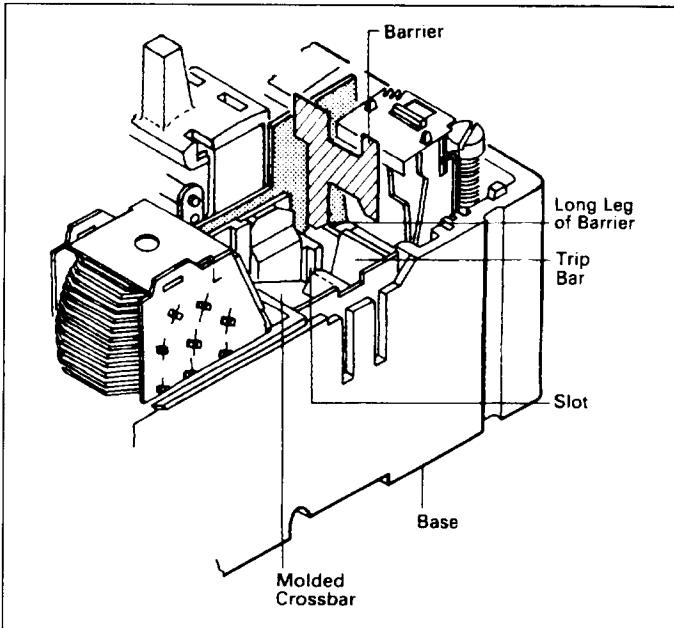

Fig. 2-4. Barrier Installation Position (Left Accessory Mounting Cavity Shown)

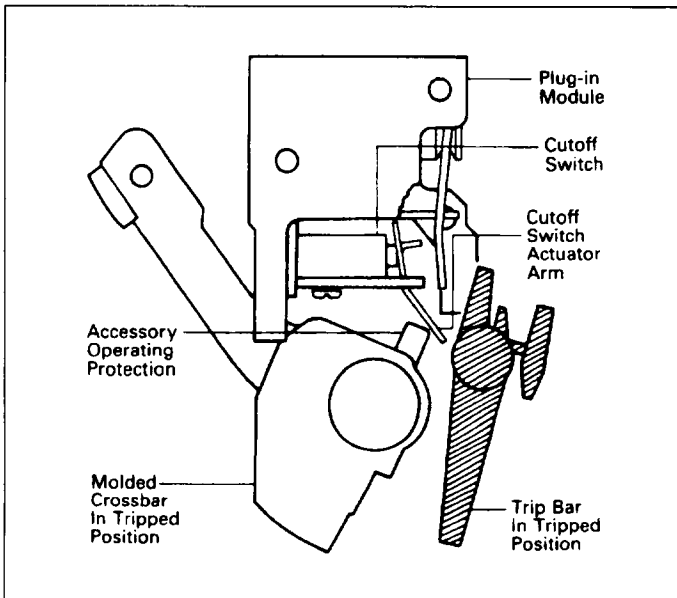

Fig. 2-5. Correct Position for Cutout Switch Actuator Arm and Molded Crossbar

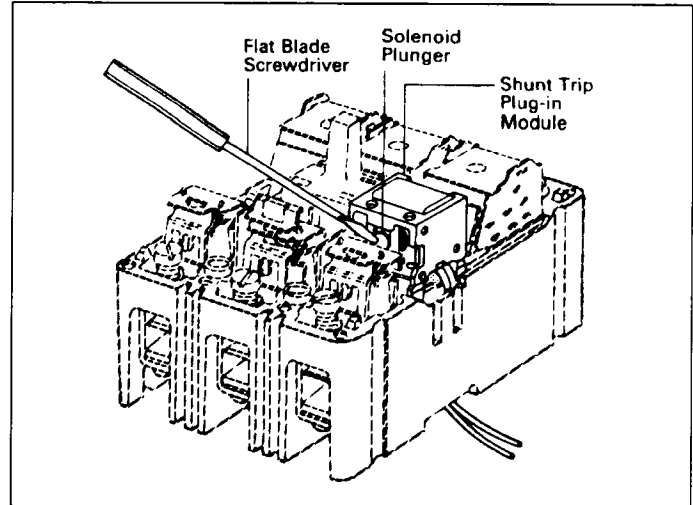

Fig. 2-6. Shunt Trip Mechanical Check



CAUTION

WHEN INSTALLING THE CIRCUIT BREAKER COVER, MAKE SURE THAT ALL INTERNAL PARTS ARE IN PLACE:

- ARC EXTINGUISHERS ARE IN EACH ARC EXTINGUISHER CAVITY.
- INTERPHASE BARRIER IS FULLY INSERTED IN BASE.
- SLIDING HANDLE BARRIER IS CORRECTLY INSTALLED WITH *O* ON BARRIER OVER ARC EXTINGUISHER.
- *PUSH-TO-TRIP* BUTTON SHOULD BE GUIDED THROUGH HOLE IN COVER USING A SMALL SCREWDRIVER.
- COVER BAFFLE(S) IS IN PLACE IN COVER.
- PIGTAIL LEADS ARE CLEAR OF THE COVER.

2-8. With the circuit breaker handle in the OFF position and pigtail leads (if used) routed as required, install circuit breaker cover and eight cover screws.

2-9. When shunt trip is installed at a non-UL approved location, remove and discard UL listing label.

Note: When installing shunt trip in 2-pole circuit breakers or circuit breakers with cover mounted accessories, alternate label mounting positions on side of circuit breaker should be selected.

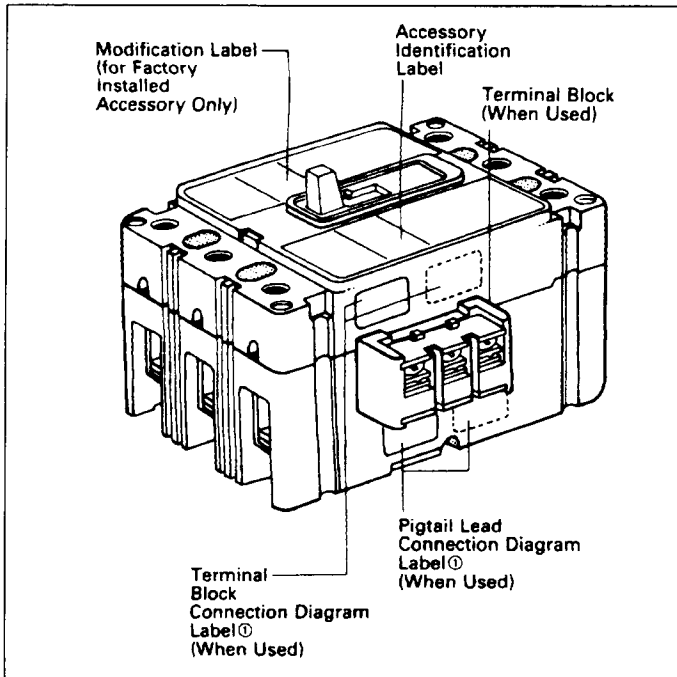

Fig. 2-7. Preferred Mounting Locations for Accessory Nameplate Labels

2-10. Place labels supplied with kit on circuit breaker. (See Fig. 2-8.)

Note: Labels on circuit breaker show connection diagram for shunt trip contacts. Pigtail leads are color coded yellow and white.

- 2-11. Test shunt trip. Connect ohmmeter across pigtail leads or terminal block connections. Check continuity as follows:
 - a. Circuit breaker handle OFF - no continuity.
 - b. Circuit breaker handle ON - less than 9000 ohms.
 - c. Press PUSH-TO-TRIP button - no continuity.

2-12. Install circuit breaker.

2-13. Connect shunt trip as required (see Fig. 2-8).

Cutler-Hammer assumes no responsibility for malfunctioning accessories installed improperly by the customer.

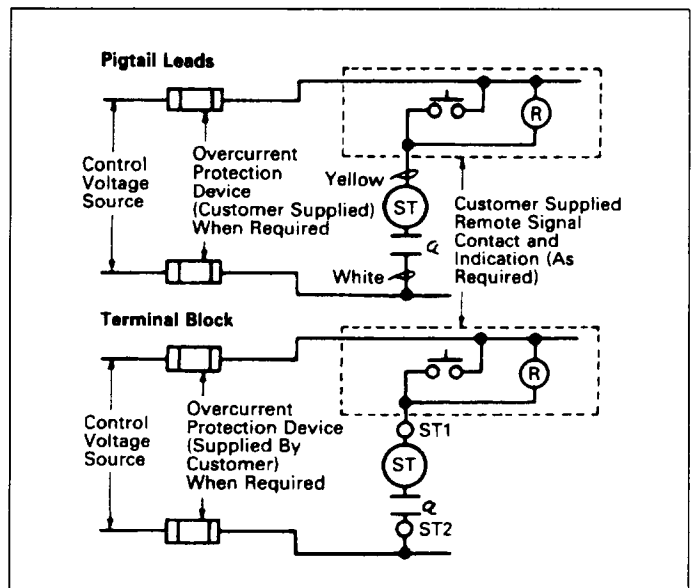

Fig. 2-8. Shunt Trip Connection Diagram

Table 1-1. Shunt Trip Electrical Rating Data

- Average unlatching time 6 milliseconds
- Average circuit breaker contact total opening time 18 milliseconds
- Endurance - 4000 electrical operations plus 4000 mechanical operations
- Shunt trip can be operated up to a maximum of six times per minute
- Maximum operating voltage 110% of maximum voltage range rating
- Terminal block is approved for use with one or two No. 18 to No. 14 AWG solid or stranded copper wire.
Torque is 7 pound-inches (0.8 N. m)

Catalog Suffix	Application Ratings		Electrical Operating Ratings (Nominal Values)						
	Voltage (V)	Frequency (Hz)	Supply Voltage (V)	Minimum Operating Voltage (V)	I _p at 0.017s (A)	I _p at 0.25s (A)	I _{rms} at 0.033s (A)	VA	One Minute Dielectric Withstand Voltage (V)
03	9-24	50/60	9	6.3	6.1		4.3	40	1048
			12		8.5		6		
			24		17		12	300	
	12-24	DC	12	8.4		8		100	
			24				16		400
08 ①	48-127	50/60	48	33.6	2.7		1.9	92	1254
			60		3.4		2.4		
			110		6.2		4.4	480	
			120		6.8		4.8	570	
			127		7.2		5.1	640	
	48-60	DC	48	33.6		2.1		100	
			60				2.6		160
12	208-380	50/60	208	146	1.2		0.88	180	1760
			220		1.3		0.93		
			240		1.4		1.00	240	
			380		2.3		1.60	610	
	110-127	DC	110	77		.50		55	
			120				.55		66
			125			.57		71	
18	415-600	50/60	400	280	1.1		0.77	310	2200
			415		1.1		0.80		
			440		1.2		0.85	380	
			480		1.3		0.93	450	
			525		1.4		1.02	530	
			550		1.5		1.06	590	
			600		1.6		1.16	700	
	220-250	DC	220	154		0.48		110	
			250				0.55		140

① Suitable for use in ground fault protection applications.

NOTES

Cutler-Hammer

Pittsburgh, Pennsylvania U.S.A.

Style No. 6620C43H06 Effective January 1998
Printed in U.S.A./CCI

