

Installation Instructions for Shunt Trip for R-Frame Series C Circuit Breakers and Molded Case Switches



SERIES C
I.L. 29C150-B
File 29-000

WARNING

CONTACT WITH ENERGIZED EQUIPMENT CAN RESULT IN DEATH, SEVERE PERSONAL INJURY, OR SUBSTANTIAL PROPERTY DAMAGE. DO NOT ATTEMPT TO INSTALL OR PERFORM MAINTENANCE ON EQUIPMENT WHILE IT IS ENERGIZED. ALWAYS VERIFY THAT NO VOLTAGE IS PRESENT BEFORE PROCEEDING WITH THE TASK, AND ALWAYS FOLLOW GENERALLY ACCEPTED SAFETY PROCEDURES.

THE WESTINGHOUSE ELECTRIC CORPORATION IS NOT LIABLE FOR THE MISAPPLICATION OR MISINSTALLATION OF ITS PRODUCTS.

The user is cautioned to observe all recommendations, warnings, and cautions relating to the safety of personnel and equipment as well as all general and local health and safety laws, codes, and procedures.

The recommendations and information contained herein are based on Westinghouse experience and judgement, but should not be considered to be all-inclusive or covering every application or circumstance which may arise. If any questions arise, contact Westinghouse Electric Corporation for further information or instructions.

1. Introduction

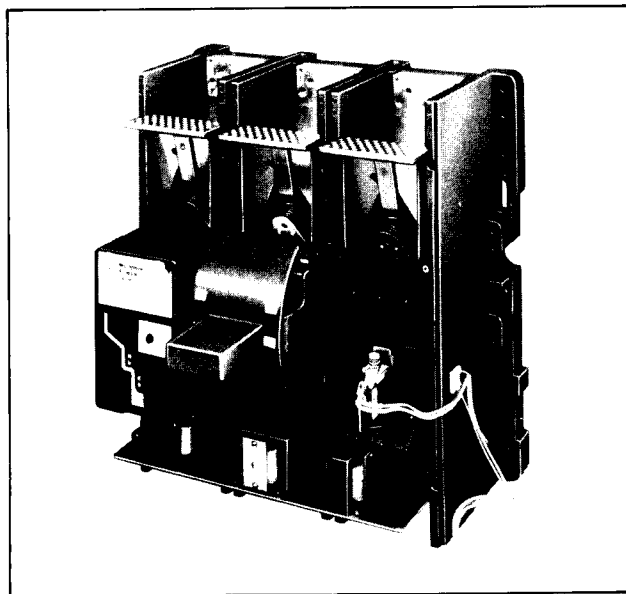

Fig. 1-1. Shunt Trip Installed in R-Frame Circuit Breaker

General Information

The shunt trip (Fig. 1-1) provides remote controlled electrical tripping for the circuit breaker. It consists of an intermittent rated solenoid with a tripping plunger and a cutoff switch attached to a plug-in module. The plug-in module is mounted

in slots in the accessory mounting deck in the right pole of the circuit breaker. When the solenoid is energized, the plunger extends and presses against the trip bar. As the circuit breaker trips, the molded trip bar rotates and allows the cutoff switch to open, disconnecting power to the solenoid and preventing coil burn out.

Table 1-1 lists application and electrical operating ratings data for the shunt trip.

The standard wiring configuration for the shunt trip is pigtail leads exiting the right side of the cover. An optional terminal block (Cat No. TBRD) may be mounted to the right side of the circuit breaker to terminate attachment leads. The 18-inch long pigtail leads are color coded for identification; numbered identification labels are provided for pigtail leads.

This instruction leaflet (IL) gives detailed procedures for installing the shunt trip.

2. Installation

Note: The shunt trip can be field-installed in RD and RDC circuit breakers under UL File E64983.

The shunt trip can be field-installed in RW and RWC circuit breakers.

The shunt trip is listed for factory installation under UL File E7819.

Before attempting to install the shunt trip, check that the catalog number is correct as ordered and that the rating of the accessory satisfies job requirements.

The shunt trip, shown in kit form in Fig. 2-1, is installed in the right pole of a 3- or 4-pole circuit breaker. To install the shunt trip, perform the following procedures:

WARNING

The voltages in energized equipment can cause death or severe personal injury. Special attention should be paid to reverse feed applications to ensure no voltage is present. Before mounting the shunt trip in a circuit breaker installed in an electrical system, make sure the circuit breaker is switched to the OFF position and there is no voltage present where work is to be performed.

Note: Internal accessories are most easily installed in a circuit breaker before it is mounted in an electrical system. Although it is recommended that a circuit breaker mounted in an electrical system be removed to install accessories, it is possible to perform this task in a mounted circuit breaker provided no voltage is present and proper safety precautions are followed.

2-1. Switch circuit breaker to OFF position.

Note: To install accessory, circuit breaker must be in tripped position.

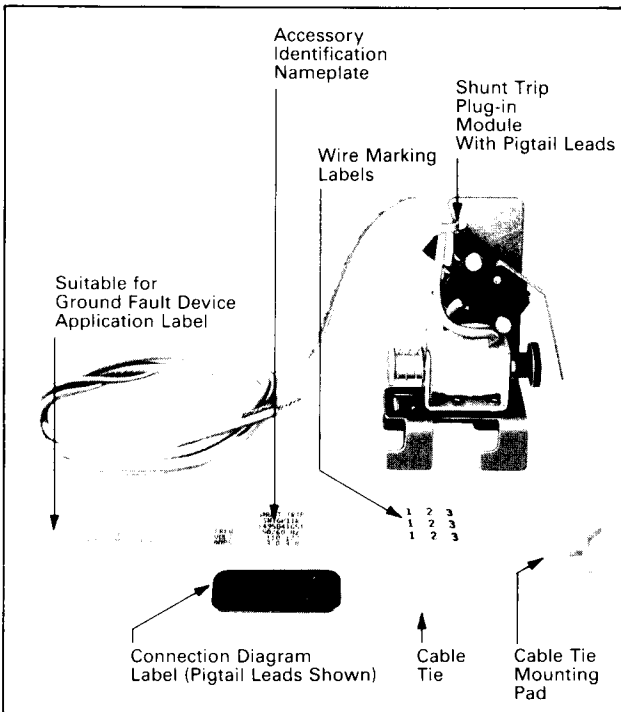

Fig. 2-1. Shunt Trip Kit

- 2-2. Press Push-to-Trip button to trip operating mechanism.
- 2-3. Remove cover screws and cover.
- 2-4. Install shunt trip as described in following steps:

Note: For ease of installation, auxiliary switch accessories (if used) should be installed in the accessory mounting deck before the shunt trip or other accessories.

- a. Select position for shunt trip on accessory mounting deck (see Fig 2-2).
- b. Place legs of shunt trip mounting bracket into slots in accessory mounting deck.
- c. Slide the shunt trip toward the line end of the circuit breaker until the retaining clip snaps into recess in deck (see Fig. 2-3).

2-5. If installing more than one shunt trip, attach a numbered wire marking label to each set of leads. Labels marked "1" and "2" are provided to allow for the installation of up to the maximum of two shunt trips.

CAUTION

Pigtail leads could be damaged if in contact with moving parts. Pigtail leads should be formed and routed to clear all moving parts when accessory is properly installed.

2-6. Attach cable tie mounting pad to side of circuit breaker (See Fig. 2-4 for location). Route leads to mounting pad. Ensure leads line up with slot in cover and are clear of all moving parts. Secure leads to mounting pad with cable tie. Leads from multiple accessories may be secured by a single cable tie and mounting pad (see Fig. 2-3).

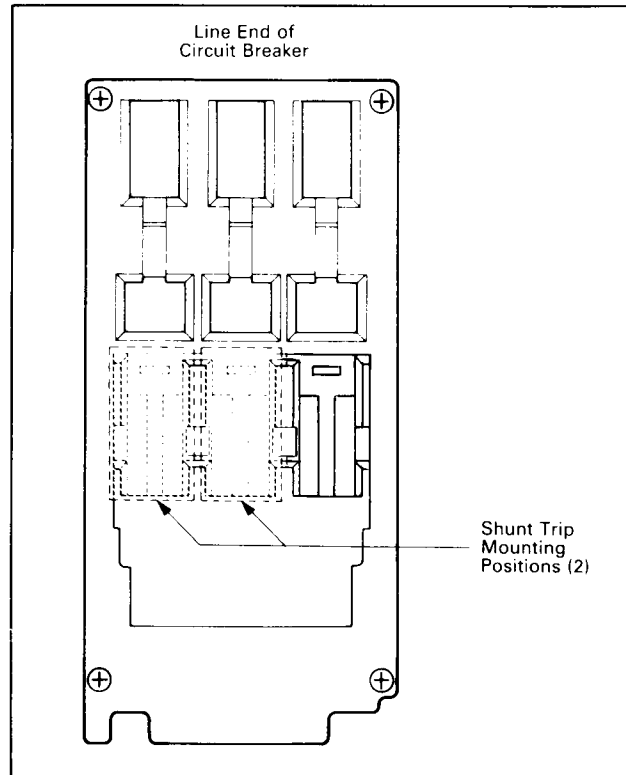

Fig. 2-2. Accessory Location Diagram

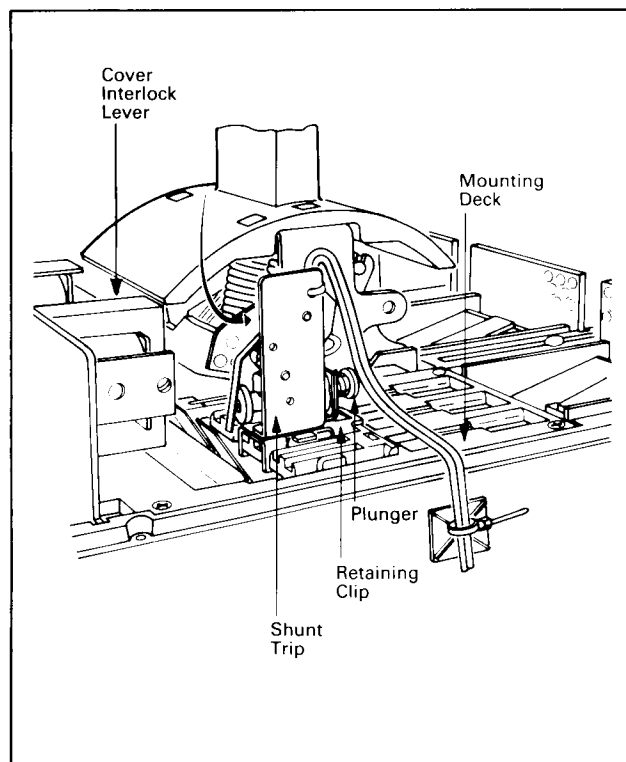

Fig. 2-3. Shunt Trip Positioned and Locked in Mounting Deck

2-7. Remove barrier indicated in Fig. 2-4 from cover accessory lead slot.

WARNING

WHEN CHECKING ACCESSORY, DO NOT PUT FINGERS NEAR MOVING PARTS INSIDE THE CIRCUIT BREAKER CASE. SPRINGS CAUSE INTERNAL PARTS TO MOVE QUICKLY AND WITH FORCE. CONTACT WITH MOVING PARTS CAN CAUSE INJURY.

Note: The circuit breaker's cover interlock will prevent the breaker from being latched while the cover is removed. The interlock consists of a spring loaded lever pivoting on the right side plate just below the handle (see Fig. 2-3). Use a tool to depress and hold the lever even with the top of the circuit breaker base while performing mechanical tests.

2-8. Perform mechanical check of shunt trip after installation:

- With the circuit breaker still electrically isolated, depress the cover interlock lever and reset circuit breaker.
- Using a small flat-blade screwdriver, depress shunt trip plunger (Fig. 2-3). Circuit breaker should move to trip position.
- If mechanical check does not trip circuit breaker, see if shunt trip is correctly installed. If shunt trip appears to be properly installed and problem persists, contact Westinghouse.

2-9. Test cutoff switch. Connect ohmmeter across pigtail leads or terminal block connections. Check continuity as follows:

- Circuit breaker tripped – no continuity.
- Circuit breaker closed – less than 9000 ohms. (Depress cover interlock lever to close breaker)
- If cutoff switch fails test, make sure that shunt trip module is properly seated in mounting deck slots. If problem persists, contact Westinghouse.

CAUTION

When installing circuit breaker cover, make sure that pigtail leads are clear of the cover.

2-10. With circuit breaker handle in tripped position and accessory pigtail leads routed as required, install circuit breaker cover.

2-11. Position accessory labels supplied with kit on circuit breaker as shown in Fig. 2-4.

Note: Accessory labels show connection diagram for shunt trip. Pigtail leads are color coded white and yellow.

2-12. Install circuit breaker.

2-13. Connect shunt trip as required (see Fig. 2-5).

Westinghouse assumes no responsibility for malfunctioning accessories installed improperly by the customer.

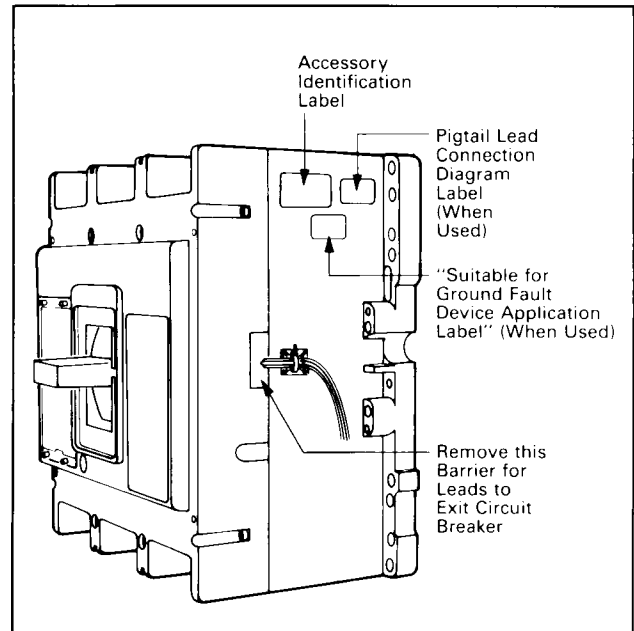

Fig. 2-4. Preferred Mounting Locations for Accessory Nameplate Labels

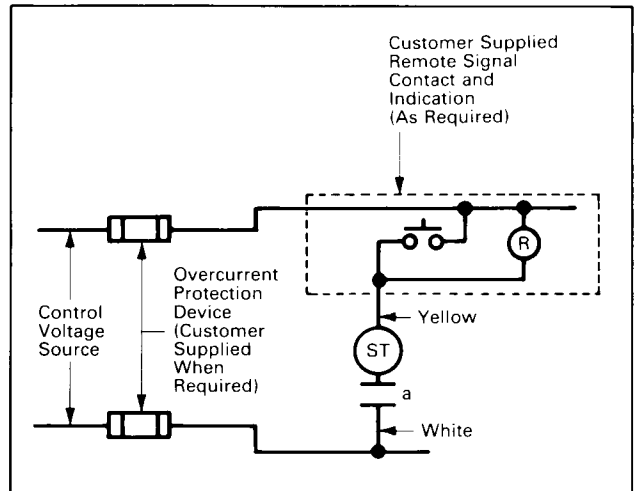

Fig. 2-5. Shunt Trip Connection Diagram

Table 1-1. Shunt Trip Electrical Ratings Data

- Average circuit breaker contact total opening time approximately 62 milliseconds, at rated voltage.
- Endurance – 500 electrical operations.
- Shunt trip can be operated up to a maximum of six times per minute.
- Maximum operating voltage – 110% of maximum voltage range rating.

Catalog Suffix	Application Ratings		Electrical Operating Ratings							
	Voltage (V)	Frequency (Hz)	Supply Voltage (V)	Minimum Operating Voltage (V)	I_p (A)	I_{rms} at 0.250s (A)	I_{rms} at 0.033s (A)	VA	One Minute Dielectric Withstand Voltage (V)	
03/03K	24	50/60	24	16.8	71.1		50.3	1210	1050	
	24	DC	24	16.8		36.1		870	1050	
05/05K	48-60	50/60	48	33.6	13.1		9.2	450	1120	
			60		17.2		12.2			740
11/11K ^①	110-240	50/60	110	60.5	4.2		3.0	330	1480	
			120		4.5		3.2			390
			127		4.6		3.3			420
			208		7.9		5.6			1170
			220		8.5		6.0			1320
			240		8.7		6.1			1470
14/14K	380-440	50/60	380	266.0	4.5		3.2	1220	1880	
			415		5.0		3.6			1500
			440		5.3		3.7			1640
	220-250	DC	220	154.0		2.4		530	1500	
			250				2.7			680
18/18K	480-600	50/60	480	336.0	0.6		.4	200	2200	
			525		0.7		.5			270
			550		0.7		.5			280
			600		0.8		.6			360
23/23K	48-60	DC	48	33.6		9.8		470	1120	
			60				11.6			700
26/26K	110-125	DC	110	77.0		3.3		370	1250	
			120				3.6			440
			125				3.8			480

^① Suitable for use with Class 1 GFP devices; marking label supplied with accessory kit.

Westinghouse Electric Corporation

Distribution and Control Business Unit
Electrical Components Division
Pittsburgh, PA 15220

Style No. 6645C97H03